

**BOSCH**

# SERVICE MANUAL

## ROOM AIR CONDITIONERS

### MODEL

INDOOR UNIT **EHP6.0AA/I**  
 OUTDOOR UNIT **EHP6.0AA/O**

### CONTENTS

**CHAPTER 1. PRODUCT SPECIFICATION**

- [1] SPECIFICATION ..... 1-1
- [2] EXTERNAL DIMENSION ..... 1-2
- [3] WIRING DIAGRM ..... 1-3
- [4] ELECTRICAL PARTS ..... 1-4

**CHAPTER 2. EXPLAMATION OF CIRCUIT AND OPERATION**

- [1] BLOCK DIAGRAMS ..... 2-1
- [2] MICROCOMPUTER CONTROL SYSTEM.... 2-3
- [3] FUNCTION..... 2-7

**CHAPTER 3. FUNCTION AND OPERATION OF PROTECTIVE PROCEDURES**

- [1] PROTECTION DEVICE FUNCTIONS AND OPERATIONS ..... 3-1
- [2] AIR CONDITIONER OPERATION IN THERMISTOR ERROR ..... 3-3
- [3] THERMISTOR TEMPERATURE CHARACTERISTICS ..... 3-5
- [4] HOW TO OPERATE THE OUTDOOR UNIT INDEPENDENTLY ..... 3-5
- [5] GENERAL TROUBLESHOOTING CHART... 3-6

- [6] MALFUNCTION (PARTS) CHECK METHOD ..... 3-7
- [7] OUTDOOR UNIT CHECK METHOD ..... 3-10
- [8] TROUBLESHOOTING GUIDE ..... 3-13
- [9] CHART ..... 3-14

**CHAPTER 4. REFRIGERATION CYCLE**

- [1] SCHEMATIC DIAGRAM ..... 4-1
- [2] STANDARD CONDITION ..... 4-1
- [3] TEMPERATURE AT EACH PART AND PRESSURE IN 3-WAY VALVE ..... 4-1
- [4] PERFORMANCE CURVES..... 4-1

**CHAPTER 5. DISASSEMBLING PROCEDURE**

- [1] INDOOR UNIT ..... 5-1
- [2] HOW TO REMOVE PLASMACLUSTER UNIT(For the models with PLASMACLUSTER) ..... 5-4
- [3] DISASSEMBLY OF OUTDOOR UNIT ..... 5-5

**Parts Guide**

Parts marked with "⚠" are important for maintaining the safety of the set. Be sure to replace these parts with specified ones for maintaining the safety and performance of the set.

# CHAPTER 1. PRODUCT SPECIFICATION

## [1] SPECIFICATION

### 1. EHP6.0AA/I – EHP6.0AA/O

ITEMS		MODEL	INDOOR UNIT EHP6.0AA/I	OUTDOOR UNIT EHP6.0AA/O
Rated cooling capacity (Min– Max.)		kW	3.5 (0.9 - 4.0)	
Rated heating capacity (Min–Max.)		kW	4.0 (0.9 - 6.0)	
Moisture removal (at cooling)		Liters/h	1.2	
Electrical data				
Phase			Single	
Rated frequency		Hz	50	
Rated voltage		V	220-240	
Rated current ☆ (Min - Max.)	Cool	A	4.7 (0.9 - 5.7 )	
	Heat	A	4.4 (0.9 - 7.4 )	
Rated input ☆ (Min - Max.)	Cool	W	1000 (200- 1250)	
	Heat	W	950 (200 - 1700)	
Power factor ☆	Cool	%	93	
	Heat	%	94	
Maximum operating current		A	8.7	
Compressor	Type	Hermetically sealed rotary type		
	Model	DA111A1F22F		
	Oil charge	450cc (Ester oil VG74)		
Refrigerant system	Evaporator	Louver Fin and Grooved tube type		
	Condenser	Corrugate Fin and Grooved tube type		
	Control	Expansion valve		
	Refrigerant (R410A)	990g		
	De-ice system	Micro computer controled reversed systems		
Noise level (at cooling)	High	dB(A)	40	47
	Low	dB(A)	–	–
	Soft	dB(A)	28	–
Fan system				
Drive			Direct drive	
Air flow quantity (at cooling)	High	m3/min.	10.6	30.2
	Low	m3/min.	8.7	–
	Soft	m3/min.	6.9	–
Fan			Cross flow fan	Propeller fan
Connections				
Refrigerant coupling			Flare type	
Refrigerant tube size Gas, Liquid			3/8", 1/4"	
Drain piping mm			O.D φ18	
Others				
Safety device		Compressor: Thermal protector		
		Fan motors: Thermal fuse		
		Fuse, Micro computer control		
Air filters		Polypropylene net (Washable)		
Net dimensions	Width	mm	860	780
	Height	mm	292	540
	Depth	mm	205	265
Net/Gross weight		kg	9/12	39/42

NOTE: The conditions of star " ☆ " marked item are based on "EN14511".

## [2] EXTERNAL DIMENSION

### 1. Indoor unit

Length unit [mm]

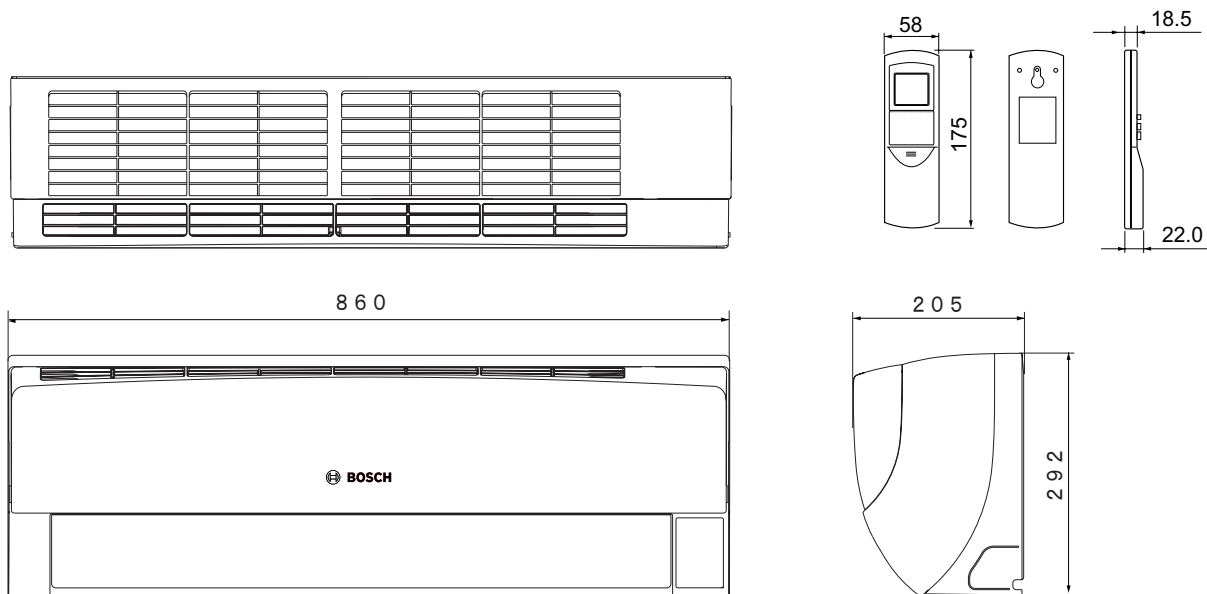

### 2. Outdoor unit

Length unit [mm]

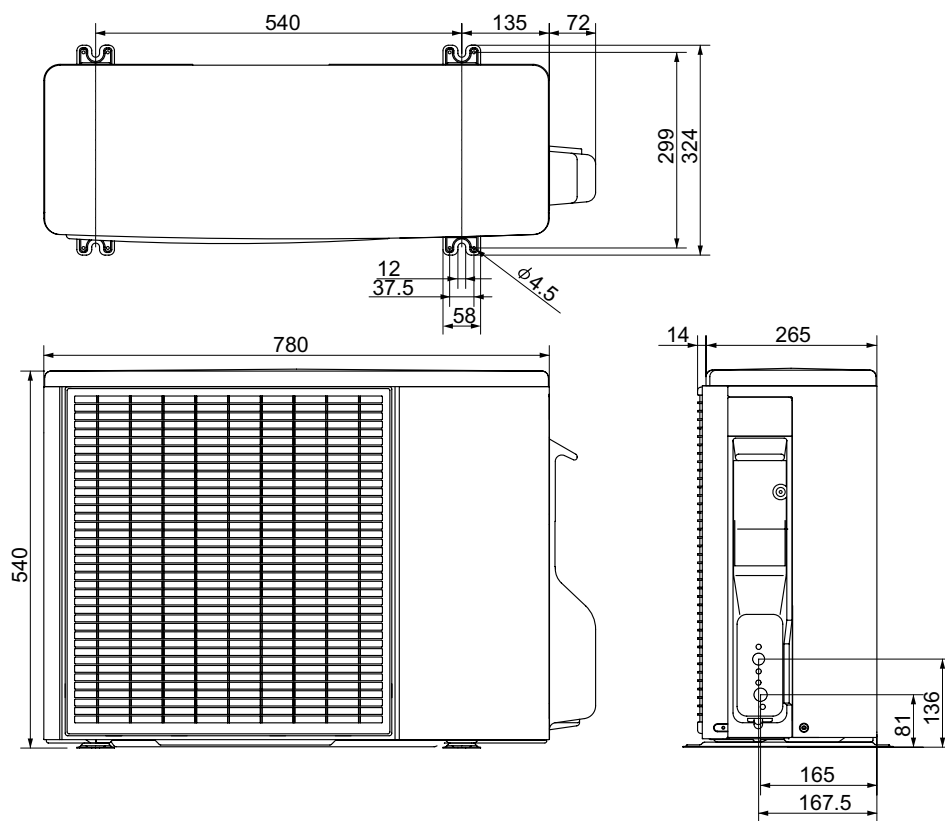

### [3] WIRING DIAGRM

#### 1. Indoor unit EHP6.0AA/I

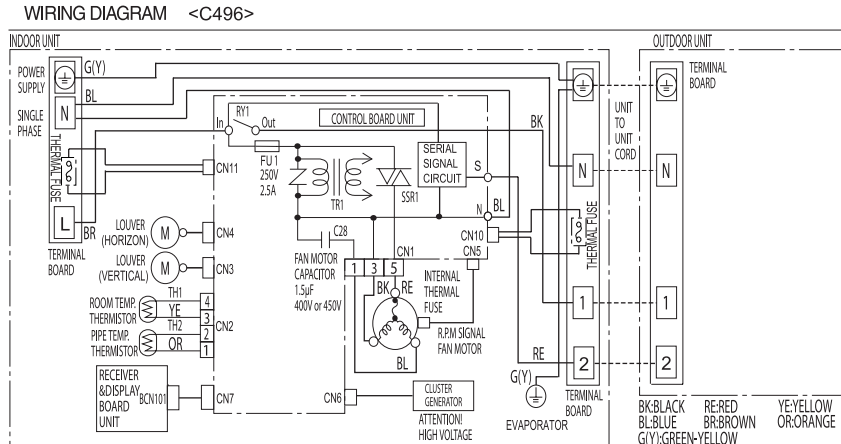

**LED INDICATION FOR SELF-DIAGNOSIS**

<Indication of the abnormal condition>  
LED indicator will blink, if the set is in abnormal condition.

	Blink step →					Abnormal contents
	X	X	X	X	X	
< LED orange blinking > LED orange blinks 5 times in 10 seconds.	X	X	X	X	X	Short circuit of the outdoor thermistor
< LED green blinking > Abnormal condition is indicated by the blinking pattern of LED green.	-	-	-	X	-	Overheat of the compressor
	-	-	X	-	X	Open circuit of the outdoor thermistor
	-	X	-	-	X	DC over current
	-	X	X	-	X	AC over current
	-	X	-	X	-	Abnormal thermistor or four way valve
	-	X	-	-	X	EEPROM error (Outdoor unit)
	-	X	X	-	X	Abnormal outdoor fan motor
	-	X	-	X	-	Thermal fuse error
	-	X	X	X	-	Abnormal compressor rotation
	-	X	X	-	X	Abnormal PAM voltage and PAM clock signal
	-	X	-	-	X	Open circuit of serial signal line
	-	X	-	X	-	Short circuit of serial signal line
X: LED blink -: LED no blink	X	-	X	X	-	Abnormal fan motor of indoor unit
	X	X	-	-	-	EEPROM error (Indoor unit)

#### 2. Outdoor unit EHP6.0AA/O

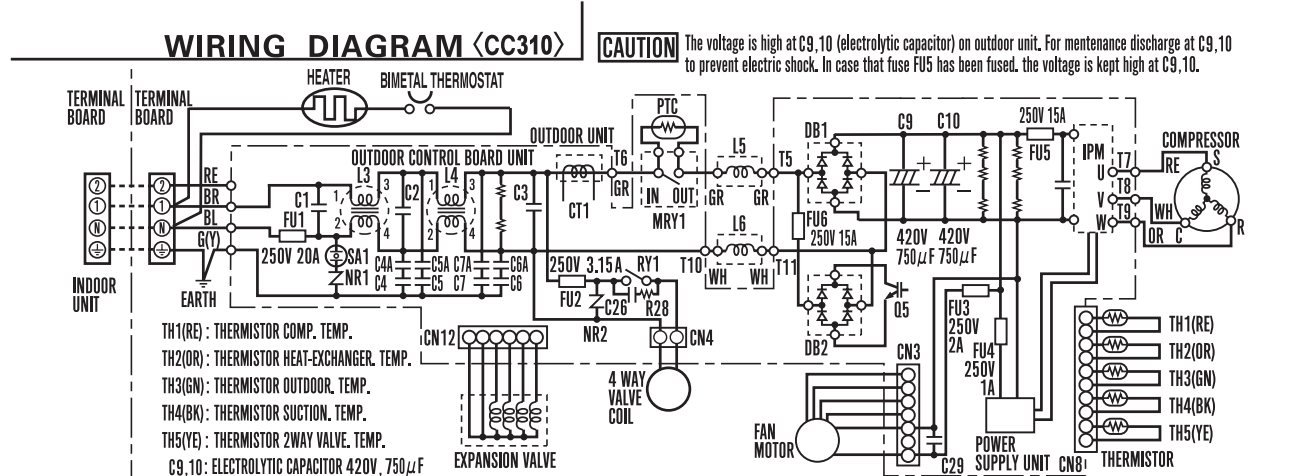

**CAUTION** The voltage is high at C9,10 (electrolytic capacitor) on outdoor unit. For maintenance discharge at C9,10 to prevent electric shock. In case that fuse FU5 has been fused, the voltage is kept high at C9,10.

**LED INDICATION SELF-DIAGNOSIS ON OUTDOOR UNIT**

No LED Indication pattern	Abnormal comments
No LED	Normal
1 ●	Abnormal signal line
2 ● × 1 time	Short circuit of the Thermistor
3 ● × 2 times	Overheat error (compressor and cycle)
4 ● × 5 times	Open circuit of the Thermistor
5 ● × 6 times	Abnormal DC current
6 ● × 7 times	Abnormal AC current

No LED Indication pattern	Abnormal comments
7 ● × 9 times	Abnormal Thermistor or four way valve
8 ● × 11 times	Abnormal outdoor fan motor
9 ● × 13 times	Rotation error of the compressor or compressor lock
10 ● × 14 times	Abnormal PAM voltage and PAM clock signal

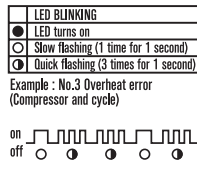

**⚠ DANGER-HIGH VOLTAGE**

The micro computer's GND line which control the thermistor, etc., share the same line of 260V line. Do not touch the control circuit components as it may result in electrical shock hazard.

Do not earth oscilloscope, etc., as it may become damaged.



**[4] ELECTRICAL PARTS****1. Indoor unit EHP6.0AA/I**

DESCRIPTION	MODEL	REMARKS
Indoor fan motor	MLB360	AC Motor
Indoor fan motor capacitor	DS401155BLSA	RC-HZA512JBZZ(400V-1.5 $\mu$ F)
Transformer	DB-EI41-5167-290mA	RTRNPA045JBZZ
FUSE1	-	QFS-IA001JBZZ (250V, 2.5A)
FUSE2	-	

**2. Outdoor Unit EHP6.0AA/O**

DESCRIPTION	MODEL	REMARKS
Compressor	DA111A1F22F	D.C. brush-less motor
Outdoor fan motor	MLB078	DC Motor
Outdoor fan motor capacitor	-	-
Fu4	-	QFS-GA064JBZZ(250V, 1A)
Fu3	-	QFS-GA051JBE0(250V, 2A)
Fu2	-	QFS-GA052JBZZ(250V, 3.15A)
Fu1	-	QFS-CA001JBZZ(250V, 20A)
Fu5, 6	-	QFS-CA002JBZZ(250V, 15A)

# CHAPTER 2. EXPLANATION OF CIRCUIT AND OPERATION

## [1] BLOCK DIAGRAMS

### 1. Indoor unit

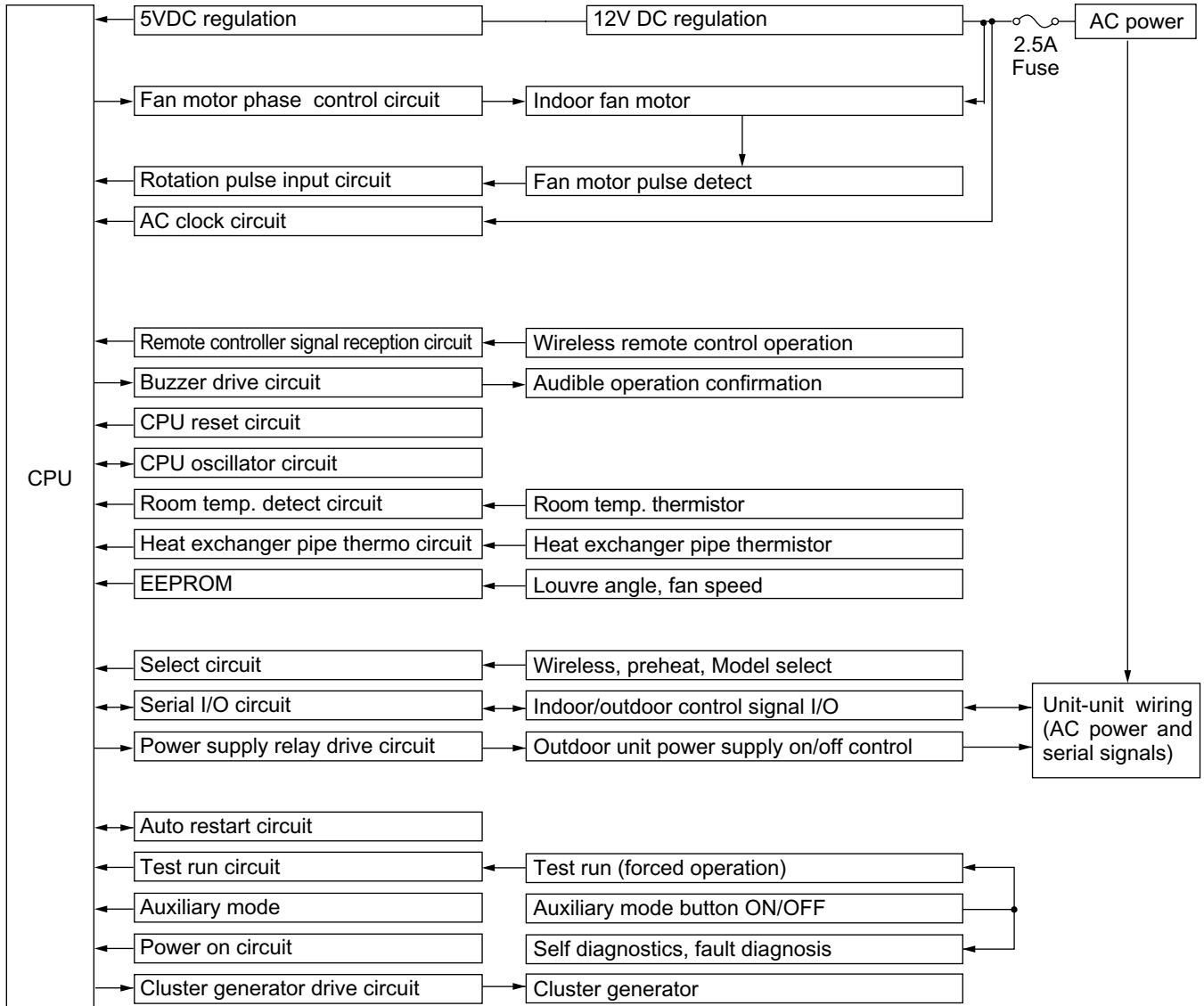

2. Outdoor unit

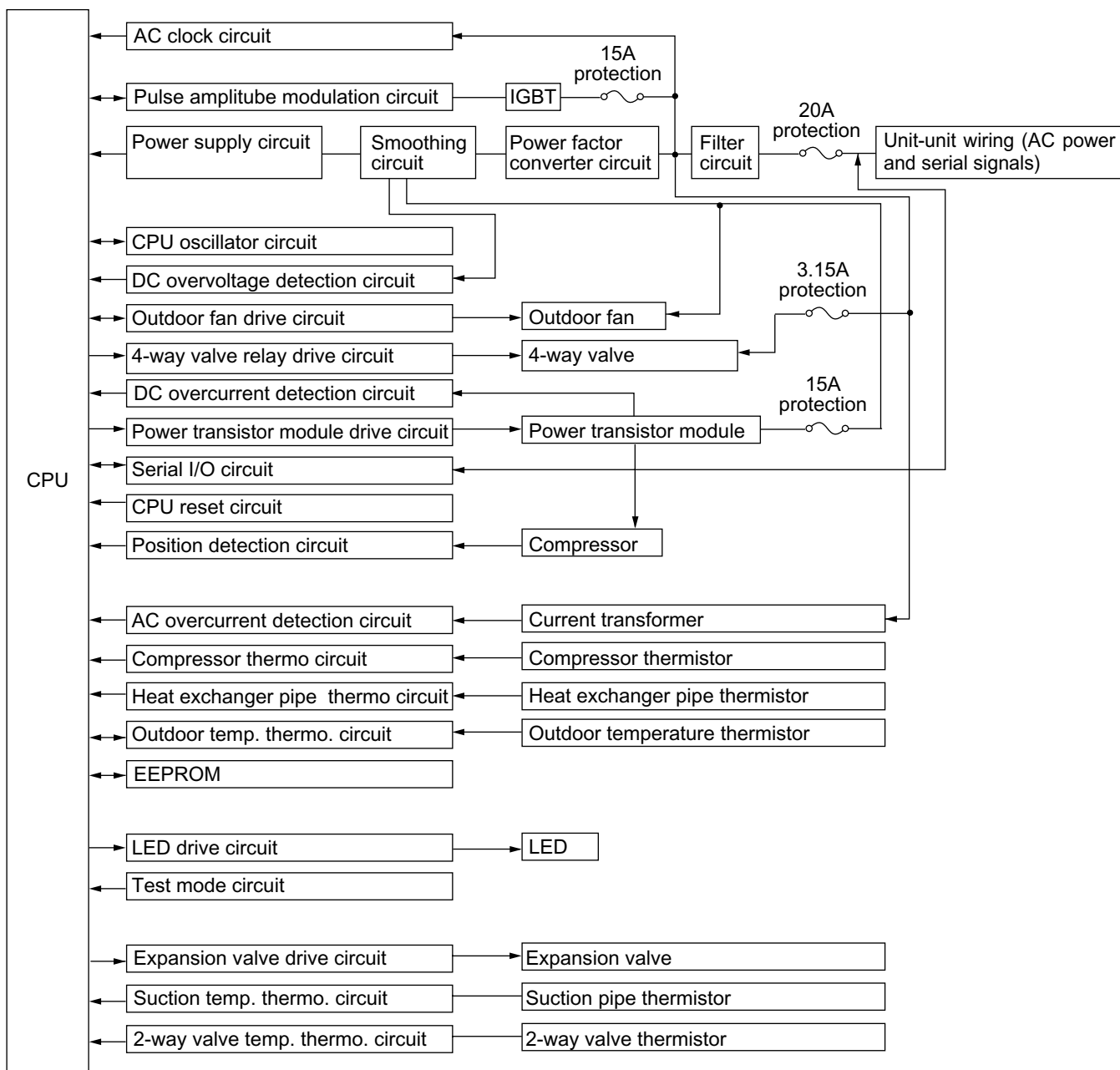

# [2] MICROCOMPUTER CONTROL SYSTEM

## 1. Indoor unit

### 1.1. Electronic control circuit diagram

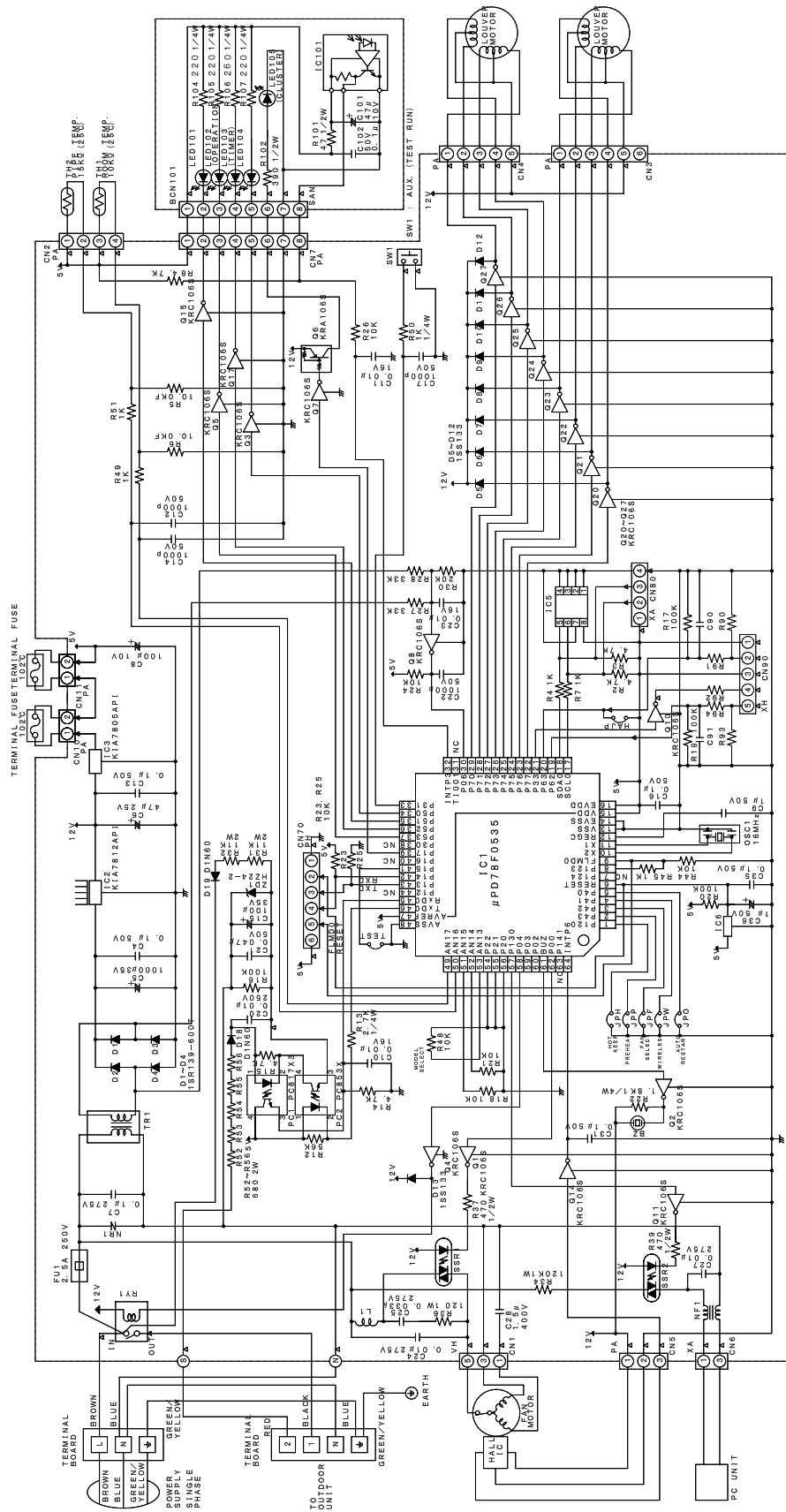

※All the resistors power is 1/10W if it is not indicated in the value.  
△:TEST POINT

1.2. Printed wiring board

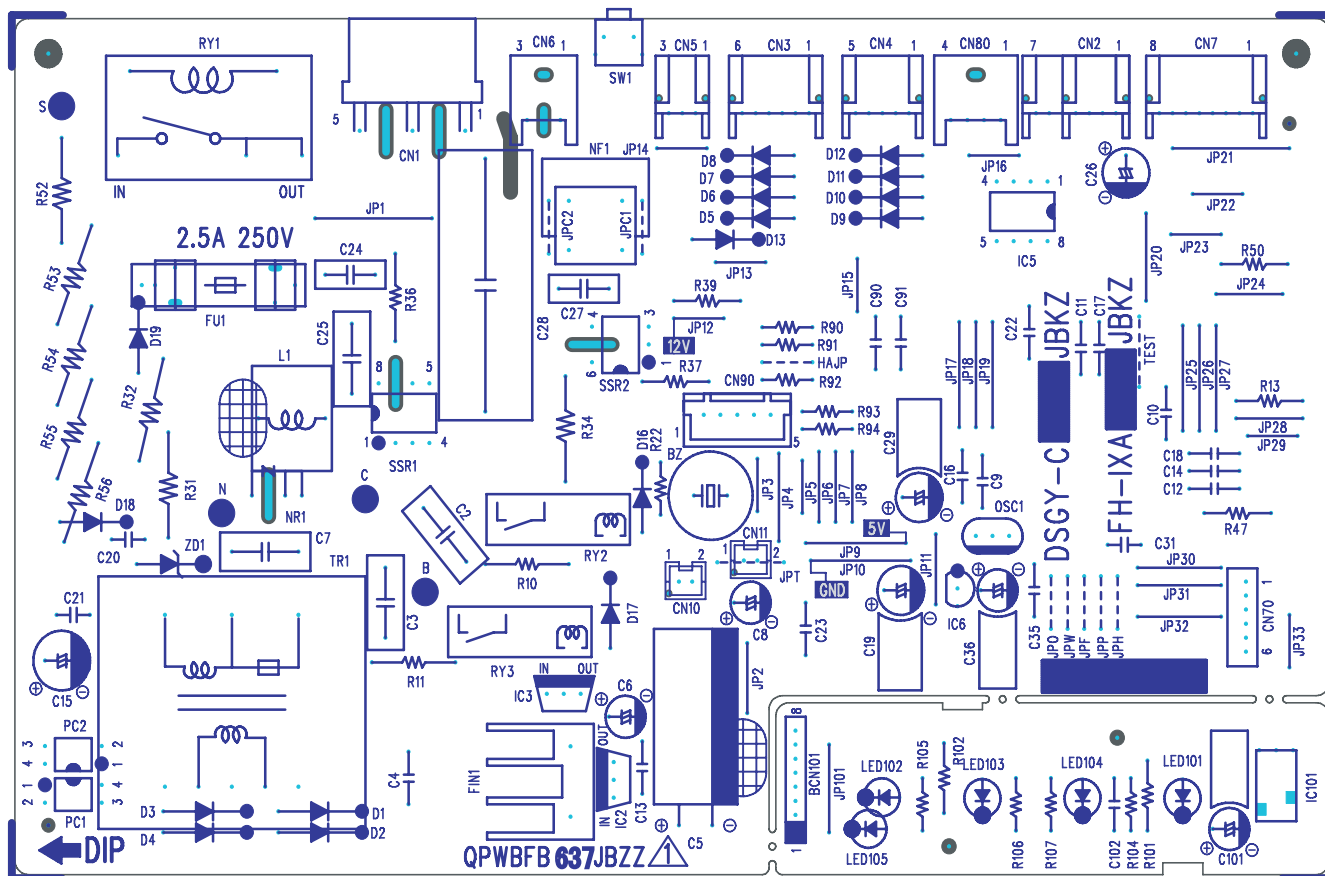

SILKTOP SILKTOPCUT

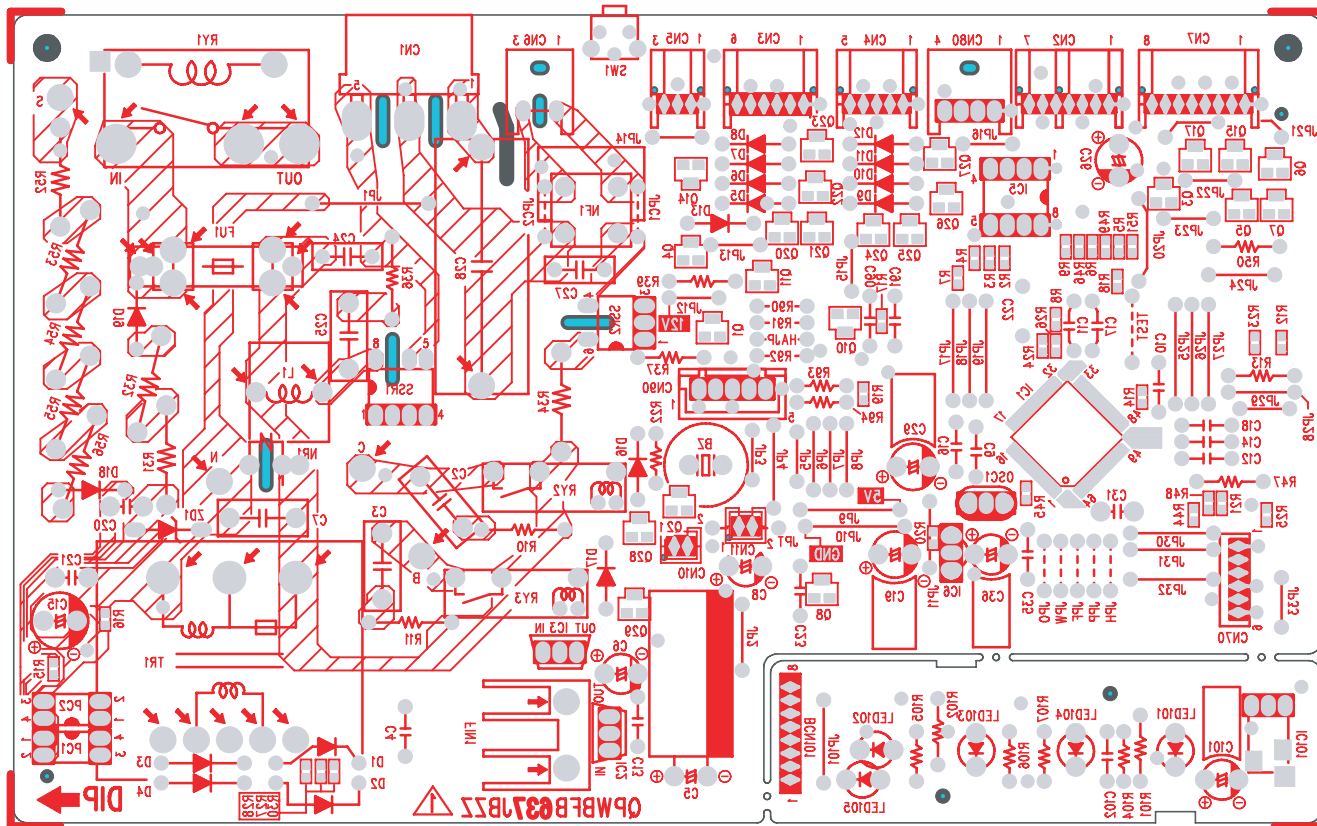

SILKTOPCUT SILKTOP

2. Outdoor unit

2.1. Electronic control circuit diagram

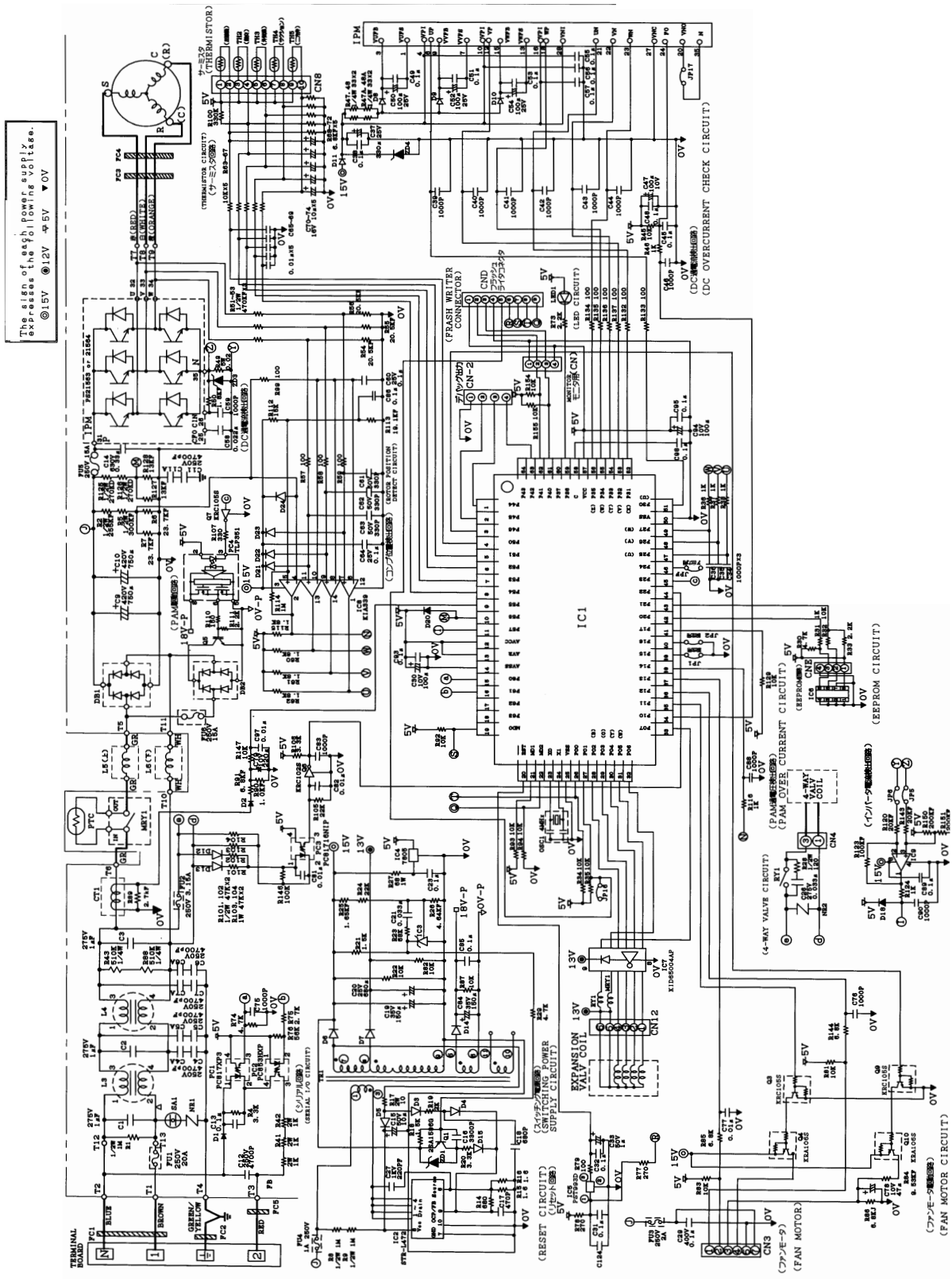

## 2.2. Printed wiring board

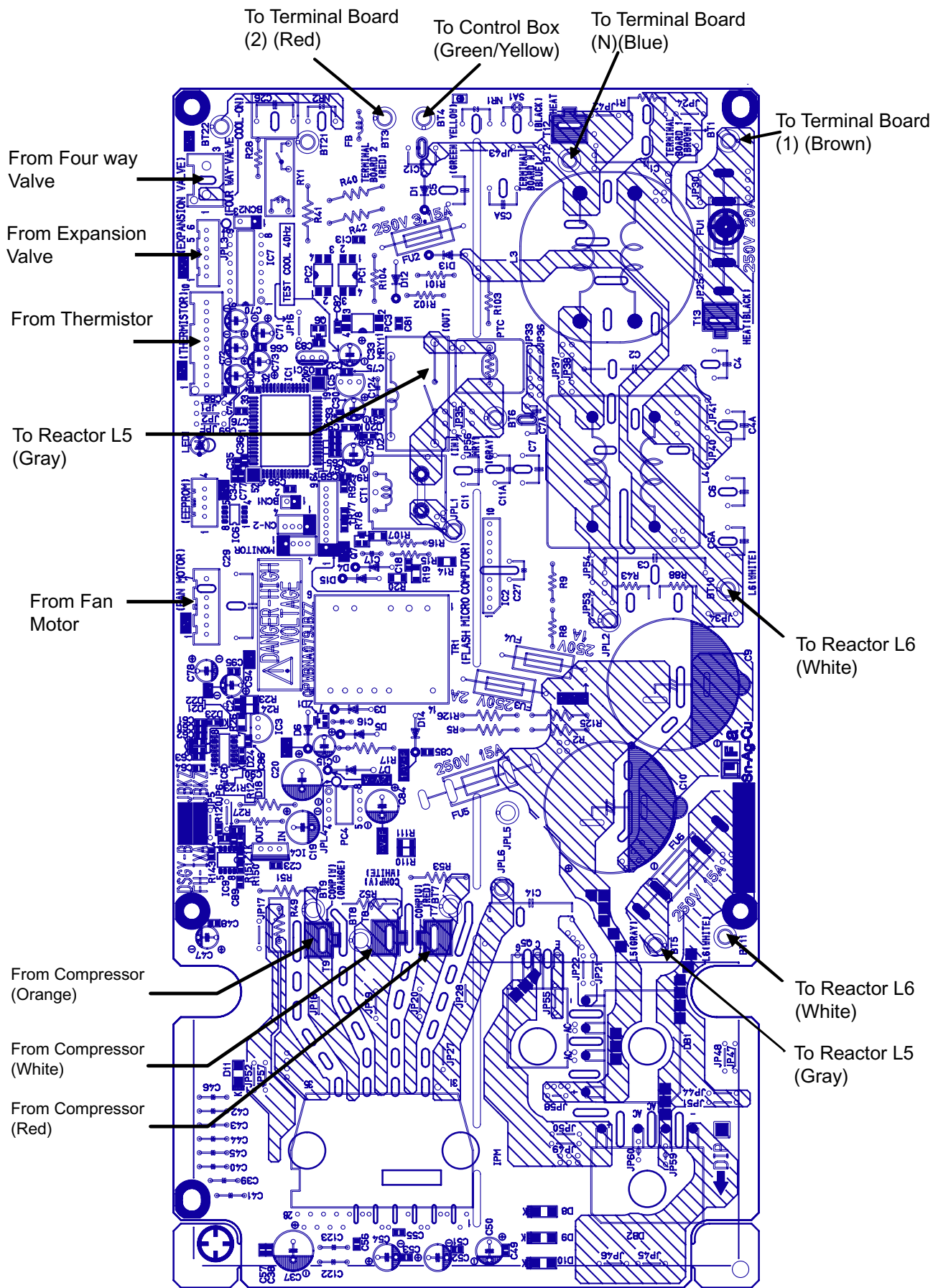

### [3] FUNCTION

#### 1. Function

##### 1.1. Startup control

The main relay remains off during the first 45 seconds (first safety time) immediately after the power cord is plugged into an AC outlet in order to disable outdoor unit operation and protect outdoor unit electric components.

##### 1.2. Restart control

Once the compressor stops operating, it will not restart for 180 seconds to protect the compressor.

Therefore, if the operating compressor is shut down from the remote control and then turned back on immediately after, the compressor will restart after a preset delay time.

(The indoor unit will restart operation immediately after the ON switch is operated on the remote control.)

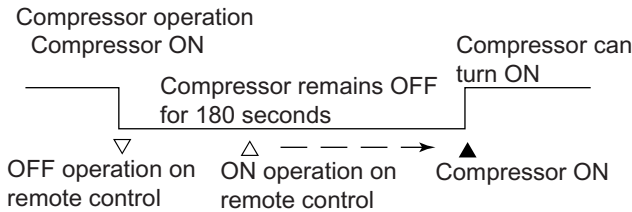

##### 1.3. Cold air prevention control

When the air conditioner starts up in heating mode, the indoor unit fan will not operate until the temperature of the indoor unit heat exchanger reaches about 23°C in order to prevent cold air from blowing into the room.

Also, the indoor unit fan operates at low speed until the temperature of the indoor unit heat exchanger reaches about 38°C so that people in the room will not feel chilly air flow.

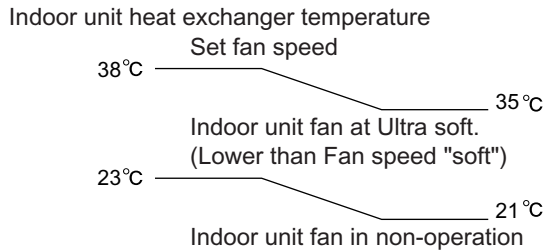

##### 1.4. Indoor unit heat exchanger freeze prevention control

If the temperature of the indoor unit heat exchanger remains below 0°C for 4 consecutive minutes during cooling or dehumidifying operation, the compressor operation stops temporarily in order to prevent freezing.

When the temperature of the indoor unit heat exchanger rises to 2°C or higher after about 180 seconds, the compressor restarts and resumes normal operation.

##### 1.5. Outdoor unit 2-way valve freeze prevention control

If the temperature of the outdoor unit 2-way valve remains below 0°C for 10 consecutive minutes during cooling or dehumidifying operation, the compressor operation stops temporarily in order to prevent freezing.

When the temperature of the 2-way valve rises to 10°C or higher after about 180 seconds, the compressor restarts and resumes normal operation.

##### 1.6. Indoor unit overheat prevention control

During heating operation, if the temperature of the indoor unit heat exchanger exceeds the indoor unit heat exchanger overheat prevention temperature (about 45 to 54°C) which is determined by the operating frequency and operating status, the operating frequency is decreased by about 4 to 15 Hz. Then, this operation is repeated every 60 seconds until the temperature of the indoor unit heat exchanger drops below the overheat protection temperature.

Once the temperature of the indoor unit heat exchanger drops below the overheat protection temperature, the operating frequency is increased by about 4 to 10 Hz every 60 seconds until the normal operation condition resumes.

If the temperature of the indoor unit heat exchanger exceeds the overheat protection temperature for 60 seconds at minimum operating frequency, the compressor stops operating and then restarts after about 180 seconds, and the above mentioned control is repeated.

##### 1.7. Outdoor unit overheat prevention control

During cooling operation, if the temperature of the outdoor unit heat exchanger exceeds the outdoor unit heat exchanger overheat prevention temperature (about 55°C), the operating frequency is decreased by about 4 to 15 Hz. Then, this operation is repeated every 60 seconds until the temperature of the outdoor unit heat exchanger drops to about 54°C or lower.

Once the temperature of the outdoor unit heat exchanger drops to about 54°C or lower, the operating frequency is increased by about 4 to 10 Hz every 60 seconds until the normal operation condition resumes.

If the temperature of the outdoor unit heat exchanger exceeds the outdoor unit heat exchanger overheat protection temperature for (120 sec. : outdoor temperature ≥ 40°C, 60 sec. : outdoor temperature < 40°C) at minimum operating frequency, the compressor stops operating and then restarts after about 180 seconds, and the above mentioned control is repeated.

##### 1.8. Compressor overheat prevention control

If the temperature of the compressor exceeds the compressor overheat prevention temperature (110°C), the operation frequency is decreased by about 4 to 10 Hz. Then, this operation is repeated every 60 seconds until the temperature of the compressor drops below the overheat protection temperature (100°C).

Once the temperature of the compressor drops below the overheat protection temperature, the operating frequency is increased by about 4 to 10 Hz every 60 seconds until the normal operation condition resumes.

If the temperature of the compressor exceeds the overheat protection temperature (for 120 seconds in cooling operation or 60 seconds in heating operation) at minimum operating frequency, the compressor stops operating and then restarts after about 180 seconds, and the above mentioned control is repeated.

##### 1.9. Startup control

When the air conditioner starts in the cooling or heating mode, if the room temperature is 2°C higher than the set temperature (in cooling operation) or 3.5°C lower (in heating operation), the air conditioner operates with the operating frequency at maximum. Then, when the set temperature is reached, the air conditioner operates at the operating frequency determined by fuzzy logic calculation, then enters the normal control mode after a while.



### 1.10. Peak control

If the current flowing in the air conditioner exceeds the peak control current (see the table below), the operation frequency is decreased until the current value drops below the peak control current regardless of the frequency control demand issued from the indoor unit based on the room temperature.

Model	Peak control current	
	Cooling operation	Heating operation
EHP6.0AA/O	Approx. 6.1 A	Approx. 8.2 A

### 1.11. Outdoor unit fan delay control

The compressor stops immediately after cooling, dehumidifying or heating operation is shut down, but the outdoor unit fan continues operation for 50 seconds before it stops.

### 1.12. Defrosting

#### 1.12.1 Reverse defrosting

The defrost operation starts when the compressor operating time exceeds 20 minutes during heating operation, as shown below, and the outside air temperature and the outdoor unit heat exchanger temperature meet certain conditions. When the defrost operation starts, the indoor unit fan stops. The defrost operation stops when the outdoor unit heat exchanger temperature rises to about 10°C or higher or the defrosting time exceeds 10 minutes.

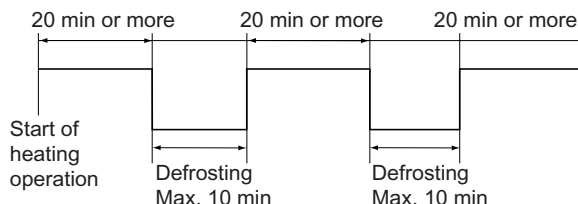

### 1.13. ON timer

The ON timer can be activated by pressing the ON timer button. When the ON timer is activated, the operation start time is adjusted based on fuzzy logic calculations 1 hour before the set time so that the room temperature reaches the set temperature at the set time.

### 1.14. OFF timer

The OFF timer can be activated by pressing the OFF timer button. When the OFF timer is set, the operation stops after the set time.

When this timer is set, the compressor operating frequency lowers for quieter operation, and the room temperature is gradually varied after one hour (reduced 1°C three times (max. 3°C) in heating, or increased 0.3°C three times (max. 1°C) in cooling or dehumidifying operation) so that the room temperature remains suitable for comfortable sleeping.

#### Heating operation

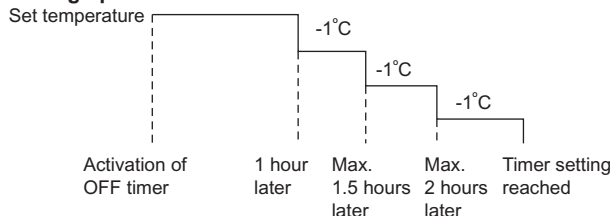

#### Cooling/dehumidifying operation

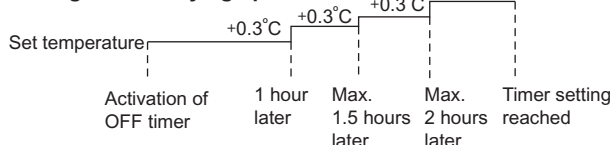

### 1.15. Power ON start

If a jumper cable is inserted in the location marked with HAJP on the indoor unit control printed circuit board (control PCB), connecting the power cord to an AC outlet starts the air conditioner in either cooling or heating mode, which is determined automatically by the room temperature sensor.

When a circuit breaker is used to control the ON/OFF operation, please insert a jumper as described above.

### 1.16. Self-diagnostic malfunction code display

#### 1.16.1 Indoor unit

1) When a malfunction is confirmed, all relays turn off and a flashing operation LED, timer LED, Plasmacluster LED is displayed to indicate the type of malfunction.

When the air conditioner is in non-operating condition, holding down AUX button for more than 5 seconds activates the malfunction code display function.

The operation continues only in the case of a serial open-circuit, and the main relay turns off after 30 seconds if the open-circuit condition remains.

In the case of a serial short-circuit, the air conditioner continues operating without a malfunction code display, and the main relay turns off after 30 seconds if the short-circuit condition remains.

The malfunction information is stored in memory, and can be recalled later and shown on display.

2) The self-diagnostic memory can be recalled and shown on the display by stopping the operation and holding down AUX button for more than 5 seconds.

(For details, refer to the troubleshooting section.)

#### 1.16.2 Outdoor unit

If a malfunction occurs, LED1 on the outdoor unit flashes in 0.2-second intervals as shown below.

#### (Example) Compressor high temperature abnormality

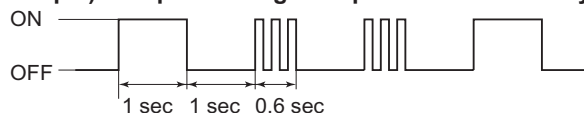

### 1.17. Information about auto mode

In the AUTO mode, the temperature setting and mode are automatically selected according to the room temperature and outdoor temperature when the unit is turned on.

#### Modes and Temperature Settings

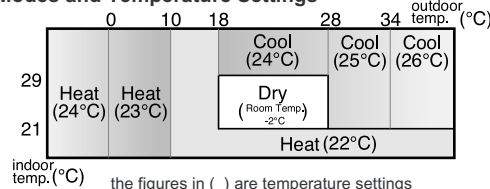

During operation, if the outdoor temperature changes, the temperature settings will automatically slide as shown in the chart.

**1.18. Airflow control**

**AIR FLOW DIRECTION**

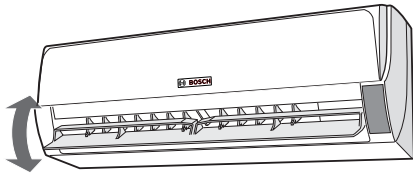

- 1) Press the SWING button (↕) on the remote control once.
  - The vertical adjustment louvre will swing continuously.
- 2) Press the SWING button (↕) again when the vertical adjustment louvre is at the desired position.
  - The louvre will stop moving within the range shown in the diagram.
  - The adjusted position will be memoried and will be automatically set to the same position when operated the next time.

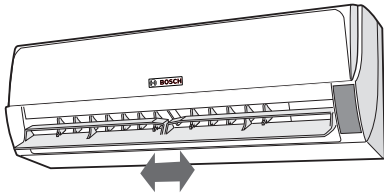

- 1) Press the SWING button (↔) on the remote control once.
  - The horizontal adjustment louvres will swing continuously.
- 2) Press the SWING button (↔) again when the horizontal adjustment louvres are at the desired position.
  - The adjusted position will be memorized and will be automatically set to the same position when operated the next time.

**1.20. Difference of operation in Auto and Manual modes**

In the Auto mode, the temperature setting is automatically determined based on the outside air temperature. In addition, the air conditioner operation differs from the operation in the Manual mode as explained below.

**1.21. Difference relating to set temperature**

	Auto mode			Manual mode		
	Cooling	Heating	Dehumidifying	Cooling	Heating	Dehumidifying
Temperature setting method	Automatic temperature setting based on outside air temperature. Can be changed within ±2°C using remote control.			Can be changed between 18 and 32°C using remote control.	Can be changed between 18 and 32°C using remote control.	Automatic setting. Can be changed within ±2°C.

**1.22. Dehumidifying operation control**

If the room temperature is 26°C or higher when dehumidifying operation starts, the dehumidifying operation provides a low cooling effect in accordance with the room temperature setting automatically determined based on the outside air operation. (The setting value is the same as the set temperature for cooling operation in the auto mode.)

If the room temperature is lower than 26°C when dehumidifying operation starts, the dehumidifying operation minimizes the lowering of the room temperature.

**1.23. FULL POWER Operation**

In this operation, the air conditioner works at the maximum power and optimum louvre direction to make the room cool or warm rapidly.

During operation, press the FULL POWER button.

**CAUTION:**

Never attempt to adjust the louvres manually.

- Manual adjustment on the louvres can cause the unit to malfunction. Position in the COOL or DRY mode for an extended period of time,
- When the vertical adjustment louvre is positioned at the lowest condensation may result.

**1.19. PROGRESSIVE AIR FLOW**

Press the PROGRESSIVE AIR FLOW button during cooling or dry operation when you do not want to feel cold air.

Vertical adjustment louvre is set obliquely upward to deliver cool air to the ceiling.

Press the button during heating operation. Vertical adjustment louvre is set downward to deliver the warm air down to the floor and warm you.

During operation, press the PROGRESSIVE AIR FLOW button.

- The remote control will display "☐"

**TO CANCEL**

Press the PROGRESSIVE AIR FLOW button again.

**NOTE:**

- The PROGRESSIVE AIR FLOW setting is cancelled When you press TURBO button while PROGRESSIVE AIR FLOW is set.
- If you want AIR FLOW operation in FULL POWER mode, press PROGRESSIVE AIR FLOW button during FULL POWER operation.

- The remote control will display "☐"
- The temperature display will go off.
- The green FULL POWER lamp on.
- The unit will light up.

**TO CANCEL**

Press the FULL POWER button again.

- The FULL POWER operation will also be cancelled when the operation mode is changed, or when the unit is turned off.

- The green FULL POWER lamp on the unit will turn off

**NOTE:**

- The air conditioner will operate at "Extra HIGH" fan speed for 5

minutes, and then shift to "HIGH" fan speed. The vertical adjustment louvre will be set obliquely downward.

- You can not set the temperature or fan speed during the FULL POWER operation.
- To turn off the FULL POWER lamp, press the DISPLAY button.

#### 1.24. Self Clean operation

Heating or Fan operation and Cluster operation are performed simultaneously.

The judgment of whether Heating or Fan operation is used is based on the outside air temperature at 3 minutes after the start of internal cleaning.

The operation stops after 40 minutes.

- During this operation the horizontal louvre moves and stays two positions.

It turns to the lower direction and stays for 30 minutes.

Next moves upward and stays for 10 minutes.

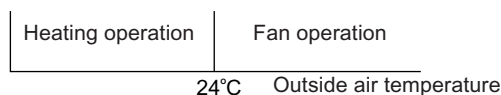

#### 1.25. Plasmacluster Ion function

Operating the Plasmacluster Ion button while the air conditioner is in operation or in non-operation allows the switching of the operation mode in the following sequence: "Air Clean operation" → "Stop".

- "Air Clean operation" generates about equal amounts of (+)ions and (-)ions from the cluster unit to provide clean air.

If the Plasmacluster Ion generation function is operated together with the air conditioner operation, the indoor unit fan speed and louvre direction are in accordance with the air conditioner settings.

If the Plasmacluster Ion generation function is used without operating the air conditioning function, the indoor unit fan operates at a very low speed and the upper louvre is angled upward and the lower louvre remains horizontal. (The airflow volume and direction can be changed by using the remote control.)

#### 1.26. 10°C OPERATION

Heating operation with 10°C set temperature will be performed.

- 1) Press the MODE button of Remote controller and select HEAT mode.
- 2) Press the ON / OFF button to start HEAT operation.
- 3) Press the 10°C button.
  - The remote control will display 10°C.

TO CANCEL

Press the 10°C button again.

- 10°C operation will also be cancelled when the operation mode is changed, or when the unit is turned off.

NOTE:

- 10°C operation will not be available with heating operation automatically selected by AUTO mode.

#### 1.27. Hot keep

If the room temperature is in the Hot keep zone during heating, the compressor is turned off to prevent overheating.

ZONE	COMPRESSOR	FAN
Hot keep (When room temperature reaches setting temperature)	OFF	Ultra soft (Lower than Fan speed "soft")

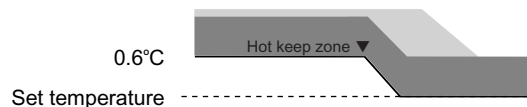

#### 1.28. Winter cool

Cooling operation is available during the winter season by the built in winter cool function.

Lower limit of outdoor temperature range is -10°C DB.

When the outside air temperature is low, the outdoor unit fan operates at slower speed.

NOTE: Built-in protect device may work when outdoor temperature falls below 21°C DB., depending on conditions.

#### 1.29. Auto restart

When power failure occurs, after power is recovered, the unit will automatically restart in the same setting which were active before the power failure.

##### 1.29.1 Operating mode (Cool, Heat, Dry)

- Temperature adjustment (within 2°C range) automatic operation
- Temperature setting
- Fan setting
- Air flow direction
- Power ON/OFF
- Automatic operation mode setting
- Swing louvre
- Plasmacluster mode

##### 1.29.2 Setting not memorized

- Timer setting
- Turbo operation setting
- Self clean operation

##### 1.29.3 Disabling auto restart function

By removing (cutting) jumper ○ (JP ○) on the printed circuit board (PCB), the auto restart function can be disabled.

### 2. Explanation of cluster circuit

The cluster unit generates cluster ions, which are circulated throughout the room by the air flow created by the blower fan (indoor unit fan motor) in the air conditioner unit.

- 1) When microcomputer output turns "H," the Q11 output changes to "Lo," turning ON the SSR2 and applying 100 V to the cluster unit for the generation of cluster ions (positive and negative ions).

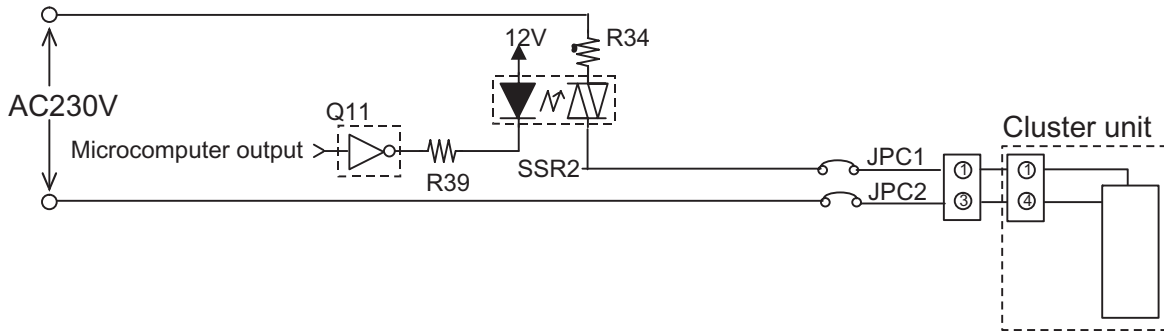

### 3. Outline of PAM circuit

#### 3.1. PAM (Pulse Amplitude Modulation)

The PAM circuit varies the compressor drive voltage and controls the rotation speed of the compressor.

The IGBT shown in the block diagram charges the energy (electromotive force) generated by the reactor to the electrolytic capacitor for the inverter by turning ON and OFF.

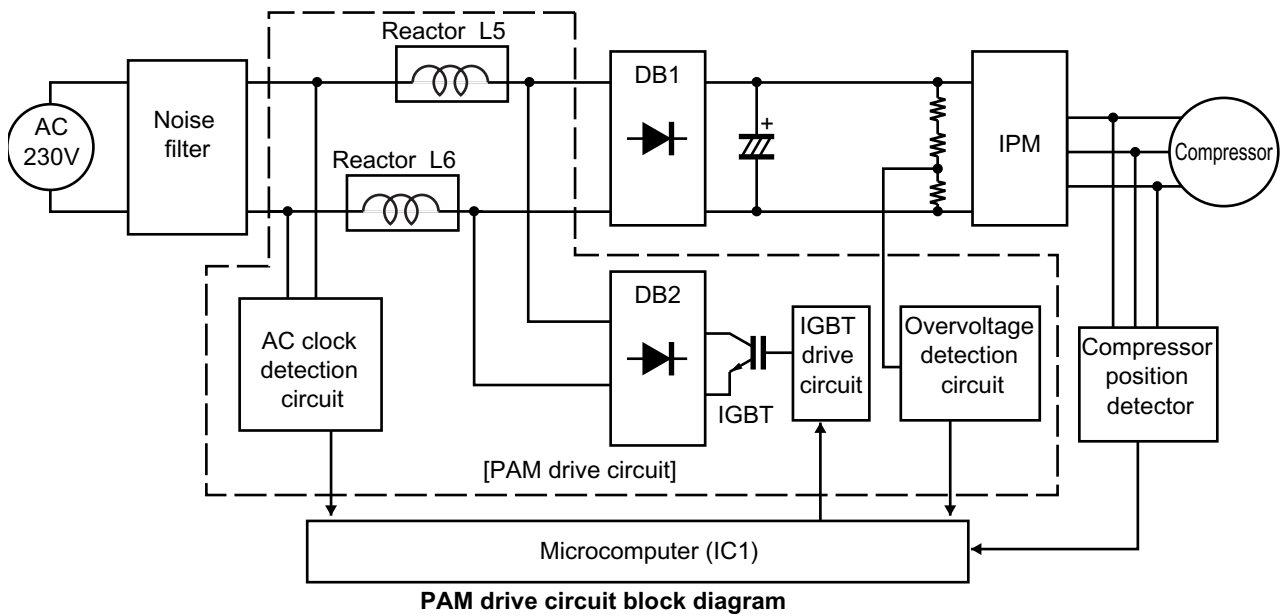

When the IGBT is ON, an electric current flows to the IGBT via the reactor (L5,L6) and diode bridge (DB2).

When the IGBT turns OFF, the energy stored while the IGBT was ON is charged to the voltage doubler capacitor via the diode bridge (DB1).

As such, by varying the ON/OFF duty of the IGBT, the output voltage is varied.

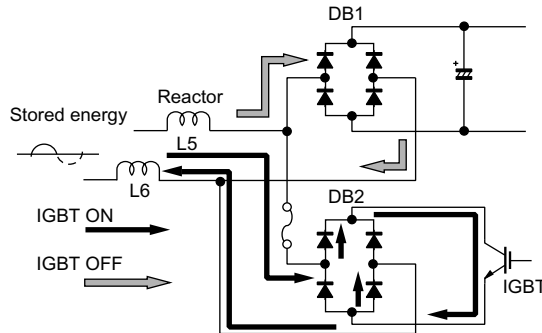

### 3.2. High power factor control circuit

This circuit brings the operating current waveform closer to the waveform of commercial power supply voltage to maintain a high power factor. Because of the capacitor input, when the PAM circuit is OFF, the phase of the current waveform deviates from the voltage waveform as shown below. To prevent this deviation, a current is supplied during the periods indicated by "O" in the diagram. To determine the length of period to supply a current, the zero-cross timing of the AC input voltage is input to the microcomputer via the clock circuit. The power source frequency is also determined at the same time. The IGBT turns ON after the time length determined by the zero-cross point to supply a current to the IGBT via the reactor. This brings the current waveform closer to the voltage waveform in phase. As described above, the ON/OFF operation of the IGBT controls the increase/decrease of the compressor power supply voltage (DC voltage) to improve the compressor efficiency and maintain a high power factor by keeping the current phase closer to that of the supply voltage.

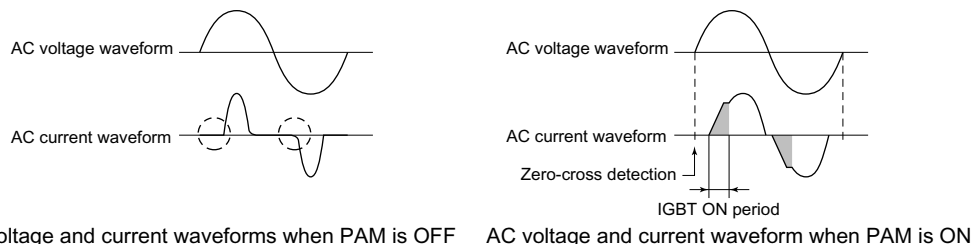

#### 3.2.1 Detailed explanation of PAM drive circuit sequence

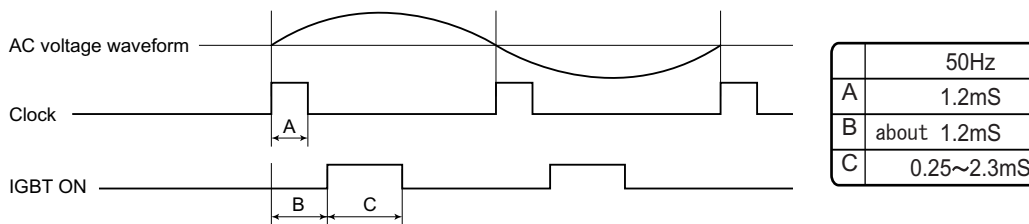

#### 3.2.2 AC clock (zero-cross) judgment

- The clock circuit determines the time from one rising point of the clock waveform to the next rising point. The detected clock waveform is used to judge the power source frequency (50Hz).
- The zero-cross of the AC voltage is judged as the rising of the clock waveform, as shown in the diagram above.

#### 3.2.3 IGBT ON start time (delay time B)

- Based on the zero-cross of the AC voltage, the IGBT turns ON after a delay time set according to the power source frequency.

#### 3.2.4 IGBT ON time (C)

- After the above delay time, the IGBT turns ON to supply a current to the reactor.
- The ON time of the IGBT determines the amount of energy (level of DC voltage rise) supplied to the reactor.

DC voltage level in each operation mode (varies depending on external load conditions)

- Cooling operation --- 220 to 240 V
- Heating operation --- 220 to 280 V

### 3.3. PAM protection circuit

To prevent excessive voltage of PAM output from damaging the IPM and electrolytic capacitor as well as the control printed circuit board (PCB), this circuit monitors the PAM output voltage and turns off the PAM control signal and PAM drive immediately when an abnormal voltage output is generated. At the same time, it shuts off the compressor operation.

The PAM output voltage is distributed to pin (4) of the comparator (IC8). If this voltage exceeds the reference voltage at pin (5) of the IC8, the output of the comparator (IC8) reverses (from H to L) and it is input to pin (38) of the microcomputer (IC1) to halt the PAM drive.

The protection voltage level is as follows.

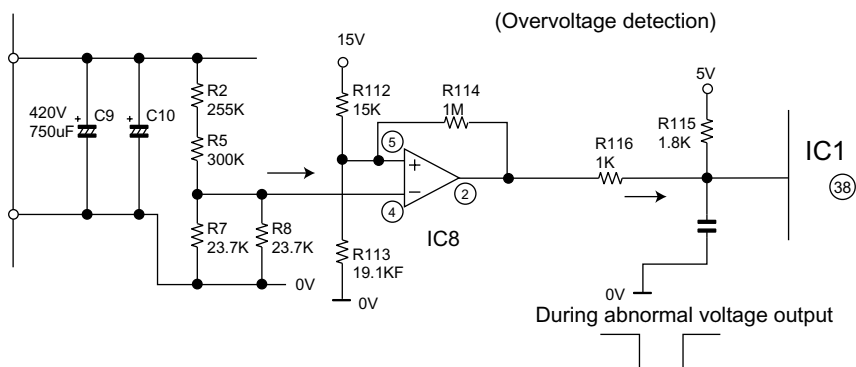

### 3.3.1 Details of troubleshooting procedure for PAM

#### 1) PAM shutdown due to error

- 1) When the DC voltage detection circuit sends a signal exceeding the specified voltage to the microcomputer  
DC voltage of 350 V or higher (detection circuit input voltage of about 9.2 V or higher) [IC8 pin (4)]
  - When an error is detected
    - PAM IGBT turns OFF.
    - Compressor turns OFF.
    - All units shut down completely when the error occurs four times.
- 2) When the outdoor unit clock waveform differs from the specified value immediately before the PAM IGBT turns ON
  - When there is no clock waveform input
  - When a clock signal of other than specified power source frequency (50/60 Hz) is input
  - When an error is detected
    - PAM IGBT does not turn ON.
    - Compressor operates normally.
    - Complete shutdown does not occur.

#### 2) PAM error indication

In case of error “1”

- An error signal is sent to the indoor unit as soon as an error is generated.
  - Malfunction No. 14-0 is indicated when the error code is called out by the indoor unit's self-diagnosis function.
- The LED on the outdoor unit flashes 14 times when an error is generated.
  - The LED continues flashing in the 14-time cycle even after the compressor stops operating.
  - The LED turns off (data is deleted from the memory) when the outdoor unit power is turned off.

In case of error “2”

- An error signal is sent to the indoor unit as soon as an error is judged.
  - Malfunction No. 14-1 is indicated when the error code is called out by the indoor unit's self-diagnosis function.
- The LED on the outdoor unit flashes 14 times when an error is judged.
  - The LED on the outdoor unit flashes in normal pattern when the compressor stops operating.  
(Compressor OFF or Thermostat OFF from remote control)
- \* When a user complains that the air conditioner does not provide sufficient cool air or warm air  
In addition to conventional error-generating reasons, there is a possibility that the PAM IGBT does not turn ON even if the compressor is operating.  
In that case, the DC voltage does not rise even though the compressor is operating, and lowers to the 180-VDC level.
  - Check items
    - Clock circuit check
    - PAM IGBT check
    - Fuse (Fu6) open-circuit check

## 4. Explanation of IPM drive circuit

The IPM for compressor drive is made by Mitsubishi Electric.

The power supply for the IPM drive, the shunt resistance for over current detection, etc., are provided outside the IPM (control PCB).

### 4.1. IPM drive power supply circuit

The power supply for the upper-phase IGBT (HU, HV, HW) drive employs a bootstrap system, and provides power to the upper-phase IC.

The 15-V power supply for the lower-phase IC is provided by the control printed circuit board (PCB).

#### 4.1.1 Brief explanation of bootstrap system (single power drive system)

To supply power to the upper-phase IC, the microcomputer (IC1) turns ON the lower-phase IGBT (LU, LV, LW).

This results in a charging current that flows to the electrolytic capacitor of each upper-phase IC input and charges the bootstrap capacitor with a 15V current.

The power supply for the subsequent stages is charged while the lower-phase IGBT is ON in ordinary compressor drive control.

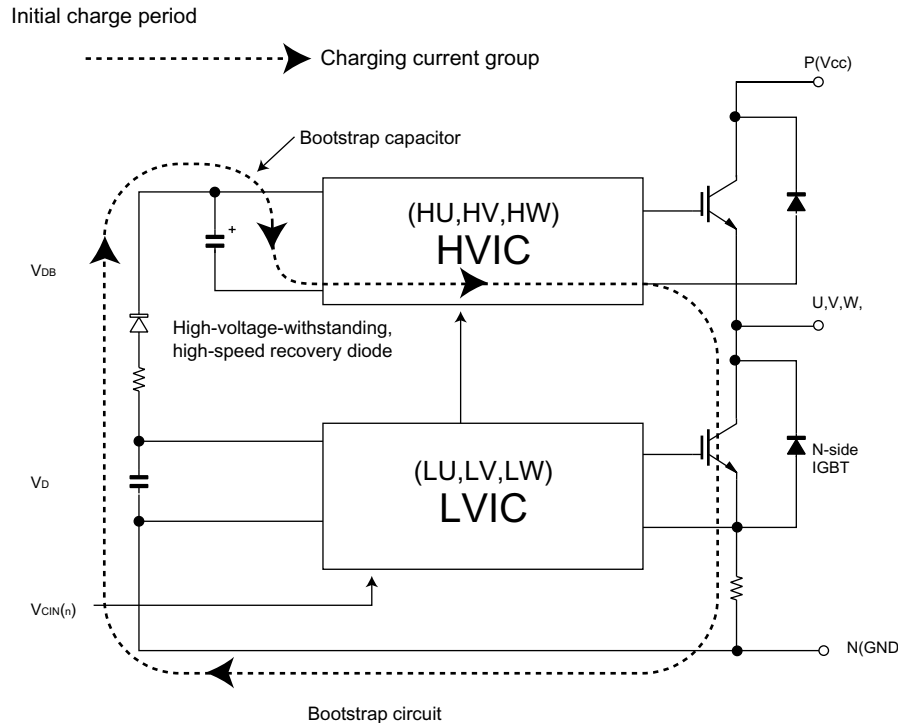

#### 4.1.2 DC over current detection circuit

When a current of about 25 A or higher flows through the shunt resistance (R49) on the control printed circuit board (PCB), the voltage at this resistance is input to IPM CIN pin (26). Then, the gate voltage of the lower-phase IGBT (LU, LV, LW) inside the IPM turns OFF to cut off the over current. At the same time, an L output of about 1.8 ms is generated from IPM Fo pin (24), and this results in an L input to overcurrent detection input pin (34) of the microcomputer (IC1) and turns OFF the PWM signal output (IC1 pins (51) through (56)) to the IGBT gate.

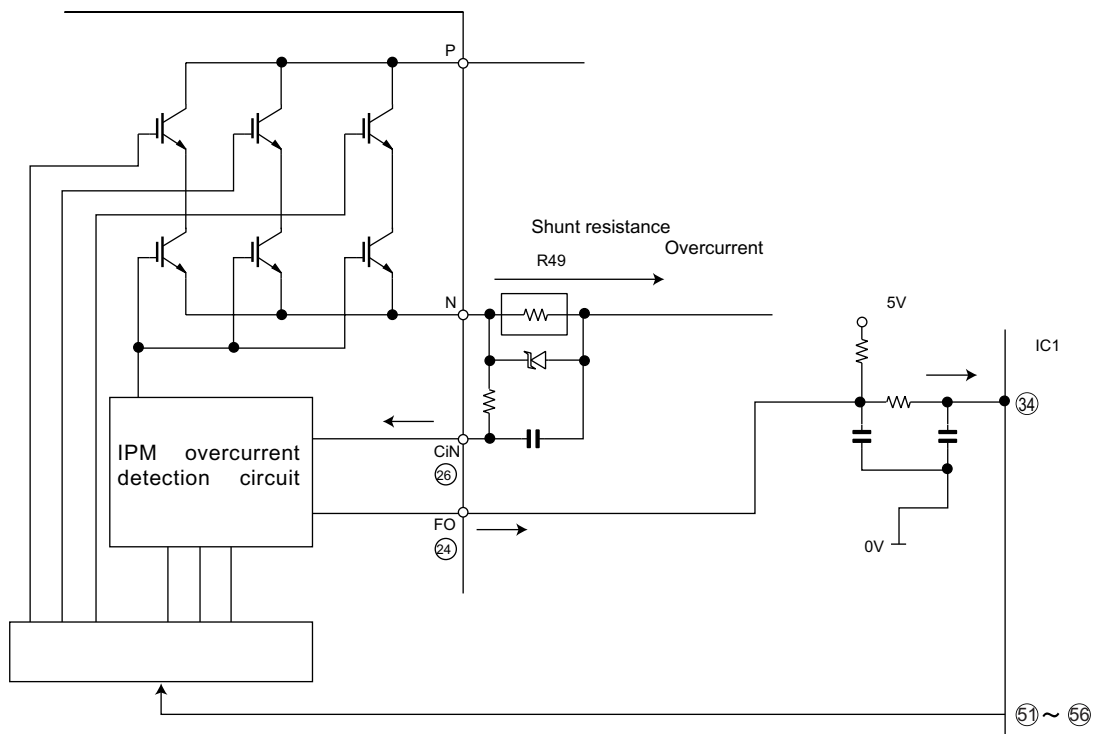
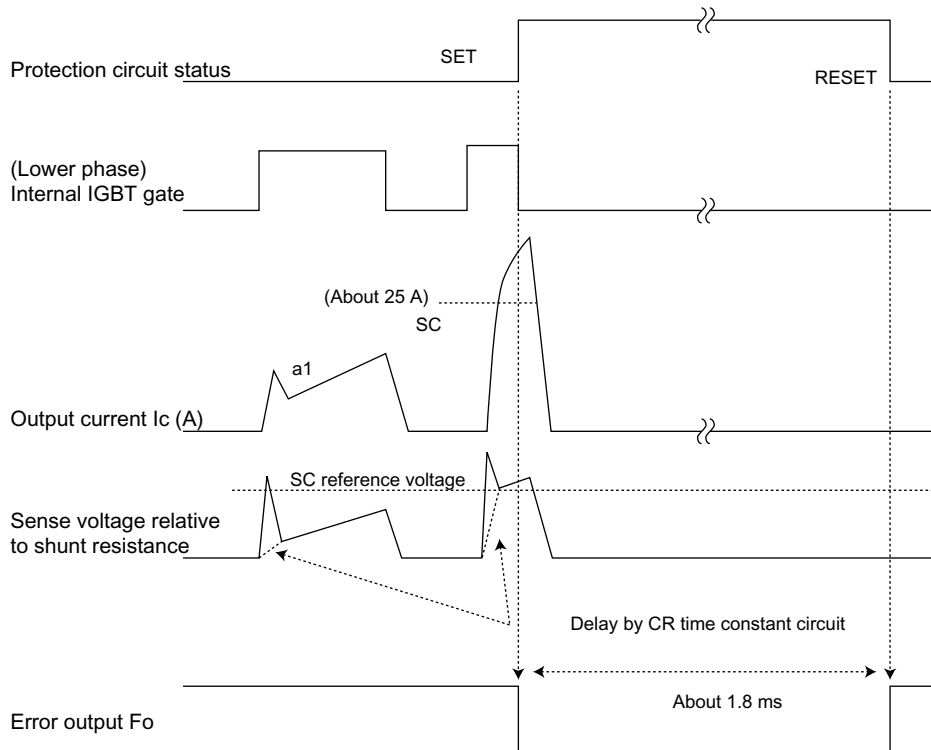



### 5. 120° energizing control (digital position detection control)

This control system detects the digital position detection signal and adjusts the rate of acceleration/deceleration accordingly.

The motor's induced voltage waveform is input to the comparator in the form of PWM-switched pulse waveform, and a position detection signal is generated as a reference voltage equaling 1/2 of 280 VDC. However, since there is no induced voltage waveform when the PWM waveform is OFF, the microcomputer performs internal processing so that detection is enabled only when it is ON. Based on the detected position signal, actual PWM waveform output timing is determined. Since it does not use a filter circuit, the detection accuracy is high.

The microcomputer performs internal processing to cancel spike voltage during the regenerative process.

Furthermore, even if the induced voltage is low, position detection is still possible, thus allowing sensor-less operation at low rotation speed in the initial stage of operation. This reduces the starting current and improves the IPM reliability.

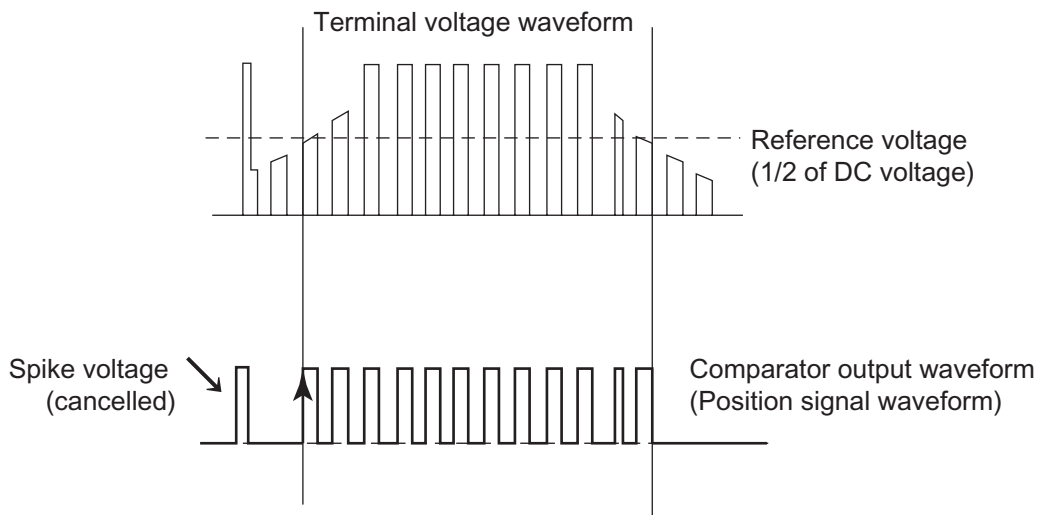

### 6. 180° Energizing Control

This is the control system to moderate the speed by the current phase difference for higher efficiency and lower noise of the compressor. The current phase difference control is the control system paid attention to the interrelation between efficiency and phase gap generated by the applied voltage of motor and current in the coil of motor as shown in the figure below.

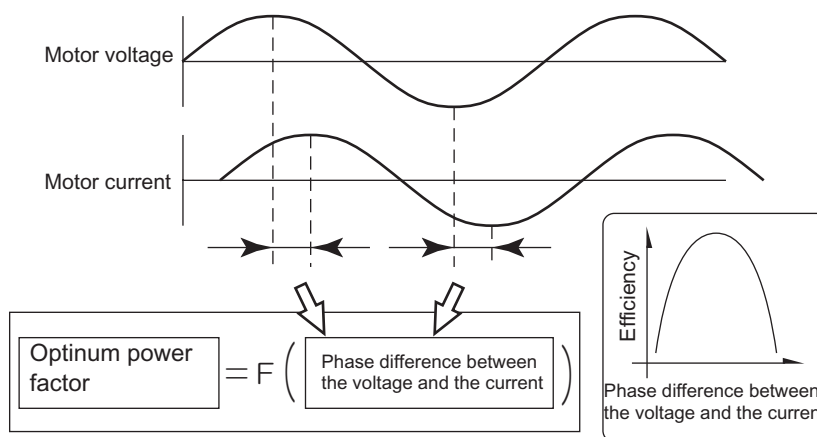

Concept chart of the current phase difference control

This control is the V/F drive system independent of the location of rotor, detecting the phase difference between driving voltage phase and line current phase flowing in motor coil, and controls the modulation rate data to get the phase difference at the best efficiency.

## CHAPTER 3. FUNCTION AND OPERATION OF PROTECTIVE PROCEDURES

### [1] PROTECTION DEVICE FUNCTIONS AND OPERATIONS

Function		Operation				Self-diagnosis result display	
		Description	Detection period	Reset condition	Indoor unit error display	Indoor unit	Outdoor unit
1	Indoor unit fan lock	Operation stops if there is no input of rotation pulse signal from indoor unit fan motor for 1 minute.	When indoor unit fan is in operation	Operation OFF or ON	I2	Yes	None
	Indoor unit fan rotation speed error	Operation stops if rotation pulse signal from indoor unit fan indicates abnormally low speed (about 300 rpm or slower).	When indoor unit fan is in operation	Operation OFF or ON	I2	Yes	None
2	Indoor unit freeze prevention	Compressor stops if temperature remains below 0°C for 4 minutes.	When in cooling or dehumidifying operation	Automatic reset when heat exchanger temperature rises above freeze prevention temperature (2°C or higher)	—	None	None
3	2-way valve freeze prevention	Compressor stops if temperature of outdoor unit 2-way valve remains below 0°C for 10 continuous minutes during cooling or dehumidifying operation.	When in cooling or dehumidifying operation	Automatic reset when temperature of 2-way valve rises above 10°C.	None	Yes	Yes
4	Indoor unit heat exchanger overheat shutdown	Operating frequency lowers if indoor unit heat exchanger temperature exceeds overheat temperature during heating operation. Compressor stops if indoor unit heat exchanger temperature exceeds overheat temperature for 60 seconds at minimum frequency. Overheat temperature setting value indoor unit heat exchanger thermistor temperature: about 45 to 54°C	When in heating operation	Automatic reset after safety period (180 sec).	None	Yes	Yes
5	Outdoor unit heat exchanger overheat shutdown	Operation frequency lowers if outdoor unit heat exchanger temperature exceeds about 55°C during cooling operation. Compressor stops if outdoor unit heat exchanger temperature exceeds about 55°C for 120 seconds at minimum frequency.	When in cooling or dehumidifying operation	Automatic reset after safety period (180 sec).	None	Yes	Yes
6	Compressor discharge overheat shutdown	Operating frequency lowers if temperature of compressor chamber thermistor (TH1) falls below about 110°C. Compressor stops if temperature of compressor chamber thermistor (TH1) remains at about 110°C (for 120 seconds in cooling operation, or 60 seconds in heating operation) at minimum frequency.	When compressor is in operation	Automatic reset after safety period (180 sec).	None	Yes	Yes
7	Dehumidifying operation temporary stop	Compressor stops if outside air temperature thermistor is lower than about 16°C during dehumidifying operation.	When in dehumidifying operation	Automatic reset when outside air temperature rises above 16°C.	None	Yes	Yes
8	DC overcurrent error	Compressor stops if electric current of about 25 A or higher flows in IPM.	When compressor is in operation	Operation OFF or ON	Yes I1	Yes	Yes

Function		Operation				Self-diagnosis result display	
		Description	Detection period	Reset condition	Indoor unit error display	Indoor unit	Outdoor unit
9	AC overcurrent error	Operating frequency lowers if compressor AC current exceeds peak control current value. Compressor stops if compressor AC current exceeds peak control current value at minimum frequency.	When compressor is in operation	Operation OFF or ON	Yes I1	Yes	Yes
10	AC overcurrent error in compressor OFF status	Indoor and outdoor units stop if AC current exceeds about 3 A while compressor is in non-operation status.	When compressor is in non-operation	Replacement of defective parts such as IPM	Yes I2	Yes	Yes
11	AC maximum current error	Compressor stops if compressor AC current exceeds 17 A.	When compressor is in operation	Operation OFF or ON	Yes I1	Yes	Yes
12	AC current deficiency error	Compressor stops if operating frequency is 50 Hz or higher and compressor AC current is about 2.0 A or lower.	When compressor is in operation	Operation OFF or ON	Yes I1	Yes	Yes
13	Thermistor installation error or 4-way valve error	Compressor stops if high and low values of temperatures detected by outdoor unit heat exchanger thermistor (TH2) and 2-way valve thermistor (TH5) do not match operating cycle.	3 minutes after compressor startup	Operation OFF or ON	Yes I1	Yes	Yes
14	Compressor high temperature error	Compressor stops if compressor chamber thermistor (TH1) exceeds about 114°C, or if there is short-circuit in TH1.	When in operation	Operation OFF or ON	Yes I1	Yes	Yes
15	Outdoor unit heat exchanger thermistor short-circuit error	Compressor stops if there is short-circuit in outdoor unit heat exchanger thermistor (TH2).	At compressor startup	Operation OFF or ON	Yes I1	Yes	Yes
16	Outdoor unit outside air temperature thermistor short-circuit error	Compressor stops if there is short-circuit in outdoor unit outside air temperature thermistor (TH3).	At compressor startup	Operation OFF or ON	Yes I1	Yes	Yes
17	Outdoor unit suction thermistor short-circuit error	Compressor stops if there is short-circuit in outdoor unit suction thermistor (TH4).	At compressor startup	Operation OFF or ON	Yes I1	Yes	Yes
18	Outdoor unit 2-way valve thermistor short-circuit error	Compressor stops if there is short-circuit in outdoor unit 2-way valve thermistor (TH5).	At compressor startup	Operation OFF or ON	Yes I1	Yes	Yes
19	Outdoor unit heat exchanger thermistor open-circuit error	Compressor stops if there is open-circuit in outdoor unit heat exchanger thermistor (TH2).	At compressor startup	Operation OFF or ON	Yes I1	Yes	Yes
20	Outdoor unit outside air temperature thermistor open-circuit error	Compressor stops if there is open-circuit in outdoor unit outside air temperature thermistor (TH3).	At compressor startup	Operation OFF or ON	Yes I1	Yes	Yes
21	Outdoor unit suction thermistor open-circuit error	Compressor stops if there is open-circuit in outdoor unit suction thermistor (TH4).	At compressor startup	Operation OFF or ON	Yes I1	Yes	Yes
22	Outdoor unit 2-way valve thermistor open-circuit error	Compressor stops if there is open-circuit in outdoor unit 2-way valve thermistor (TH5).	At compressor startup	Operation OFF or ON	Yes I1	Yes	Yes
23	Outdoor unit discharge thermistor open-circuit error	Compressor stops if there is open-circuit in outdoor unit discharge thermistor (TH1).	At compressor startup	Operation OFF or ON	Yes I1	Yes	Yes
24	Serial signal error	Power relay turns OFF if indoor unit cannot receive serial signal from outdoor unit for 8 minutes.	When in operation	Operation OFF or ON (Automatic reset when less than 8 minutes)		Yes	None
		Compressor stops if outdoor unit cannot receive serial signal from indoor unit for 30 seconds.	When in operation	Reset after reception of serial signal	None	None	None

Function		Operation				Self-diagnosis result display	
		Description	Detection period	Reset condition	Indoor unit error display	Indoor unit	Outdoor unit
25	Compressor start-up error	Compressor stops if compressor fails to start up.	At compressor start-up	Operation OFF or ON	Yes I3	Yes	Yes
26	Compressor rotation error (at 120° energizing)	Compressor stops if there is no input of position detection signal from compressor or input is abnormal.	Compressor operating at 120° energizing	Operation OFF or ON	Yes I3	Yes	Yes
27	Outdoor unit DC fan error	Operation stops if there is no input of rotation pulse signal from outdoor unit fan motor for 30 seconds.	When outdoor unit fan is in operation	Operation OFF or ON	Yes I1	Yes	Yes
28	PAM overvoltage error	Compressor stops if DC voltage is 350 V or higher.	When in operation	Operation OFF or ON	Yes I1	Yes	Yes
29	PAM clock error	When power source frequency cannot be determined (at startup), or when power source clock cannot be detected for 1 continuous second (at startup).	At compressor start-up, when in operation	Compressor continues operation without stopping.	None	Yes	Yes

I1—The outdoor unit restarts four times before the indoor unit error is displayed (complete shutdown).

I2—A single error judgment results in the display of the indoor unit error (complete shutdown).

I3—The outdoor unit restarts eight times before the indoor unit error is displayed (complete shutdown).

## [2] AIR CONDITIONER OPERATION IN THERMISTOR ERROR

### 1. Indoor unit

Item	Mode	Control operation	When resistance is low (temperature judged higher than actual)	Short-circuit	When resistance is high (temperature judged lower than actual)	Open-circuit
Room temperature thermistor (TH1)	Auto	Operation mode judgment	Cooling mode is activated even if room temperature is low.	Cooling mode is activated in most cases.	Heating mode is activated even if room temperature is high.	Heating mode is always activated.
	Cooling	Frequency control	Room becomes too cold.	Air conditioner operates in full power even when set temperature is reached.	Room does not become cool.	Compressor does not operate.
	Dehumidifying	Room temperature memory Frequency control	Normal operation.	Room temperature is stored in memory as 31.0°C, and compressor does not stop.	Normal operation.	Room temperature is stored in memory as 18.5°C, and compressor does not operate.
	Heating	Frequency control	Room does not become warm.	Hot keep status results immediately after operation starts. Frequency does not increase above 30 Hz (40 Hz).	Room becomes too warm.	Air conditioner operates in full power even when set temperature is reached.
Heat exchanger thermistor (TH2)	Cooling Dehumidifying	Freeze prevention	Indoor unit evaporator may freeze.	Indoor unit evaporator may freeze.	Compressor stops occasionally.	Compressor does not operate.
	Heating	Cold air prevention	Cold air prevention deactivates too soon and cold air discharges.	Compressor operates at low speed or stops, and frequency does not increase.	Cold air prevention deactivates too slow.	Cold air prevention does not deactivate, and indoor unit fan does not rotate.

## 2. Outdoor unit

Item	Mode	Control operation	When resistance is low (temperature judged higher than actual)	Short-circuit	When resistance is high (temperature judged lower than actual)	Open-circuit
Compressor chamber thermistor (TH1)	Cooling Dehumidifying Heating	Expansion valve control and compressor protection	Compressor operates, but room does not become cool or warm (expansion valve is open).	Compressor high temperature error indication.	Layer short-circuit or open-circuit may result in compressor in normal operation.	Outdoor unit thermistor open-circuit error indication.
Heat exchanger thermistor (TH2)	Cooling Dehumidifying	Outdoor unit heat exchanger over-heat prevention	Compressor operates at low speed or stops.	Outdoor unit thermistor short-circuit error indication.	Normal operation.	Outdoor unit thermistor open-circuit error indication.
	Heating	Expansion valve control Defrosting	Defrosting operation is not activated as needed, and frost accumulates on outdoor unit (expansion valve is closed).	Outdoor unit thermistor short-circuit error indication.	Defrosting operation is activated unnecessarily, and room does not become warm (expansion valve is open).	Outdoor unit thermistor open-circuit error indication.
Outside air temperature thermistor (TH3)	Auto	Operation mode judgment	Cooling mode is activated even if room temperature is low.	Outdoor unit thermistor short-circuit error indication.	Heating mode is activated even if room temperature is high.	Outdoor unit thermistor open-circuit error indication.
	Cooling Dehumidifying	Operation not affected	Normal operation.	Outdoor unit thermistor short-circuit error indication.	Normal operation.	Outdoor unit thermistor open-circuit error indication.
	Heating	Rating control Defrosting	Defrosting operation is activated unnecessarily.	Outdoor unit thermistor short-circuit error indication.	Defrosting operation is not activated, and frost accumulates on outdoor unit.	Outdoor unit thermistor open-circuit error indication.
Suction pipe thermistor (TH4)	Cooling Dehumidifying	Expansion valve control	Compressor operates, but room does not become cool (expansion valve is open).	Outdoor unit thermistor short-circuit error indication.	Frost accumulates on evaporator inlet section, and room does not become cool (expansion valve is closed).	Outdoor unit thermistor open-circuit error indication.
	Heating	Expansion valve control	Compressor operates, but room does not become warm (expansion valve is open).	Outdoor unit thermistor short-circuit error indication.	Frost accumulates on expansion valve outlet section, and room does not become warm (expansion valve is closed).	Outdoor unit thermistor open-circuit error indication.
2-way valve thermistor (TH5)	Cooling Dehumidifying	Expansion valve control	Frost accumulates on indoor unit evaporator and room does not become cool (expansion valve is closed).	Outdoor unit thermistor short-circuit error indication.	Compressor operates, but room does not become cool (expansion valve is open).	Outdoor unit thermistor open-circuit error indication.
	Heating	Operation not affected	Normal operation.	Outdoor unit thermistor short-circuit error indication.	Normal operation.	Outdoor unit thermistor open-circuit error indication.

### [3] THERMISTOR TEMPERATURE CHARACTERISTICS

#### 1. Indoor unit thermistor temperature characteristics

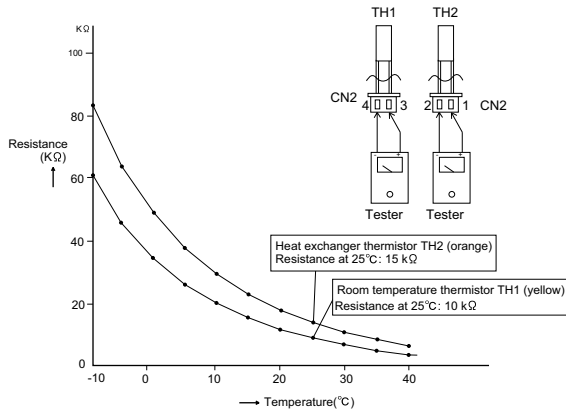

Thermistor	Symbol	Color
Room temperature	TH1 (CN2)	Yellow
Heat exchanger	TH2 (CN2)	Orange

Before measuring resistance, disconnect connectors as shown above.

TH1 Room temperature thermistor  
TH2 Heat exchanger thermistor

#### 2. Outdoor unit thermistor temperature characteristics

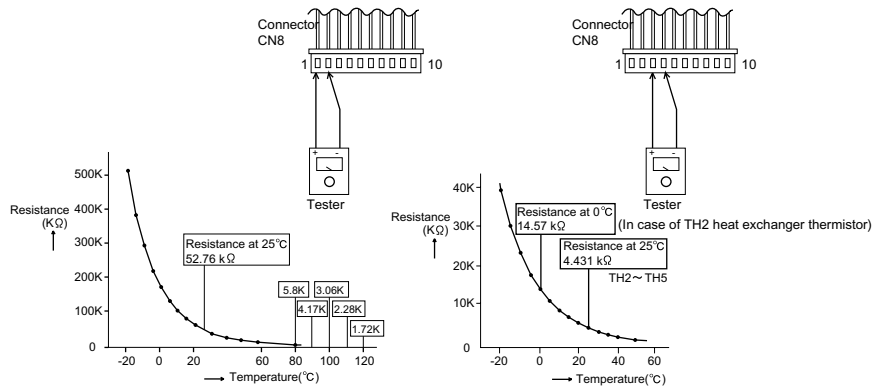

TH1 Compressor thermistor

TH2 Heat exchanger thermistor  
TH3 Outdoor air temperature thermistor  
TH4 Suction thermistor  
TH5 2-way valve thermistor

Thermistor	No.	Connector	Color
Compressor thermistor	TH1	No. (1) - No. (2)	Red
Heat exchanger thermistor	TH2	No. (3) - No. (4)	Orange
Outdoor air temperature thermistor	TH3	No. (5) - No. (6)	Green
Suction thermistor	TH4	No. (7) - No. (8)	Black
2-way valve thermistor	TH5	No. (9) - No. (10)	Yellow

Before measuring resistance, disconnect connectors from PWB.

### [4] HOW TO OPERATE THE OUTDOOR UNIT INDEPENDENTLY

#### 1. Cooling in 40 Hz fixed mode

To operate the outdoor unit independently, short-circuit the sections indicated by arrows in the diagram below with an adapter, and apply 230 VAC between (1) and (N) on the terminal board of the outdoor unit. This allows the outdoor unit to be operated in cooling mode independently.

(Do not operate the outdoor unit in this condition for an extended period of time.)

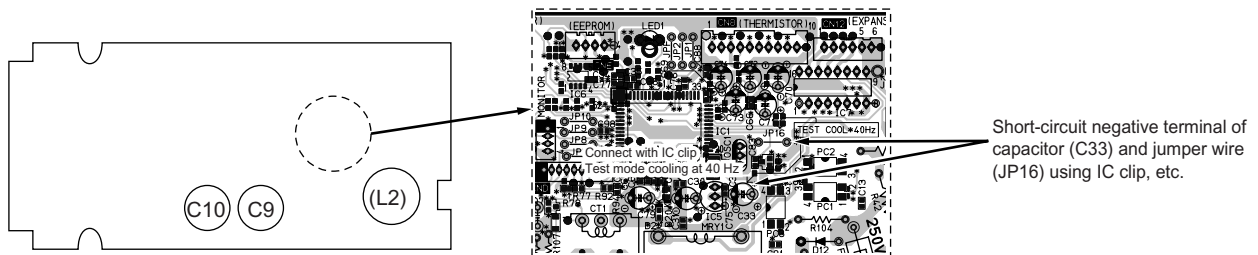

## [5] GENERAL TROUBLESHOOTING CHART

### 1. Indoor unit does not turn on

Main cause	Inspection method	Normal value/condition	Remedy
Cracked PWB. (Cracked pattern)	Check visually.	There should be no cracking in PWB or pattern.	Replace PWB.
Open-circuit in FU1 (250 V, 2.5A).	Check melting of FU1.	There should be no open-circuit.	Replace PWB.

### 2. Indoor unit fan does not operate

Main cause	Inspection method	Normal value/condition	Remedy
Open-circuit in heat exchanger thermistor (TH2) (in heating operation)	Measure thermistor resistance (dismount for check).	Refer to THERMISTOR TEMPERATURE CHARACTERISTICS-1	Replace thermistor.
		There should be no open-circuit or faulty contact.	Replace thermistor.
Disconnected heat exchanger thermistor (TH2) (in heating operation)	Inspect connector on PWB. Check thermistor installation condition.	Thermistor should not be disconnected.	Install correctly.

### 3. Indoor unit fan speed does not change

Main cause	Inspection method	Normal value/condition	Remedy
Remote control not designed to allow fan speed change.	Check operation mode.	Fan speed should change except during dehumidifying operation, ventilation, light dehumidifying operation, internally normal operation	Explain to user.

### 4. Remote control signal is not received

Main cause	Inspection method	Normal value/condition	Remedy
Batteries at end of service life.	Measure battery voltage.	2.5 V or higher (two batteries in series connection)	Install new batteries.
Batteries installed incorrectly.	Check battery direction.	As indicated on battery compartment.	Install batteries in indicated direction.
Lighting fixture is too close, or fluorescent lamp is burning out.	Turn off light and check.	Signal should be received when light is turned off.	Change light position or install new fluorescent lamp.
Use Sevick light (Hitachi).	Check if Sevick light (Hitachi) is used.	Signal may not be received sometimes due to effect of Sevick light.	Replace light or change position.
Operating position/angle is inappropriate.	Operate within range specified in manual.	Signal should be received within range specified in manual.	Explain appropriate handling to user.
Open-circuit or short-circuit in wiring of light receiving section.	Check if wires of light receiving section are caught.	Wires of light receiving section should not have any damage caused by pinching.	Replace wires of light receiving section.
Defective light receiving unit.	Check signal receiving circuit (measure voltage between terminals 7 and 8 of connector CN7).	Tester indicator should move when signal is received.	Replace PWB.
Dew condensation on light receiving unit.	Check for water and rust.	Signal should be received within range specified in manual.	Take moisture-proof measure for lead wire outlet of light receiving section.

### 5. Louvers do not move

Main cause	Inspection method	Normal value/condition	Remedy
Caught in sliding section.	Operate to see if louvers are caught in place.	Louvers should operate smoothly.	Remove or correct catching section.
Disconnected connector (CN3, CN4 on relay PWB, louver motor side)	Inspect connectors.	Connectors or pins should not be disconnected.	Install correctly.
Contact of solder on PWB (connector section on PWB)	Check visually.	There should not be solder contact.	Correct contacting section.

### 6. There is noise in TV/radio

Main cause	Inspection method	Normal value/condition	Remedy
Grounding wires not connected properly.	Check grounding wire connections.	Grounding wires should be connected properly.	Connect grounding wires properly.

Main cause	Inspection method	Normal value/condition	Remedy
TV/radio is placed too close to outdoor unit.	Check distance between TV/radio and outdoor unit.	If TV/radio is placed too close, it may become affected by noise.	Move TV/radio away from outdoor unit.

## 7. Compressor does not start

Main cause	Inspection method	Normal value/condition	Remedy
Erroneous inter-unit connection.	Check wiring between indoor and outdoor units.	Terminal board 1-N: 230 VAC, 50 Hz Terminal board 2: serial signal	Correct wiring.
Damaged IPM.	Check IPM continuity.		Replace IPM.
Dried-up electrolytic capacitor.	Check electrolytic capacitor.		Replace electrolytic capacitor.
Blown outdoor unit fuse.	Check 20-A fuse. Check 15-A fuse.	Fuse should not be blown.	Replace fuse/diode bridge. Replace fuse. Replace outdoor unit PWB assembly.
Power supply voltage is too low.	Measure power supply voltage during startup.	230±10 VAC, 50 Hz	Make sure that power supply voltage is 198 V or higher.
Compressor lock.	Supply current and touch compressor cover (sound absorbing material) to check if operation starts.	Compressor should start normally.	Apply external impact to compressor. Replace compressor.

## 8. Operation stops after a few minutes and restarts, and this process repeats

Main cause	Inspection method	Normal value/condition	Remedy
Dried-up electrolytic capacitor.	Measure 320-VDC line voltage.	250 V or higher.	Replace electrolytic capacitor.
Layer short-circuit in expansion valve coil.	Measure resistance.	46±3Ω in each phase (at 20°C)	Replace coil.

CAUTION: If fuse FU1/FU4/FU5 (outdoor unit control circuit board) is blown, be careful of charging voltage in inverter electrolytic capacitor C9, C10.

To discharge stored electricity, unplug the power cord and connect the plug of a soldering iron (230VAC, 50W) between the positive and negative terminals of inverter electrolytic capacitor C9, C10.

## [6] MALFUNCTION (PARTS) CHECK METHOD

### 1. Procedure for determining defective outdoor unit IPM/compressor

The following flow chart shows a procedure for locating the cause of a malfunction when the compressor does not start up and a DC overcurrent indication error occurs.



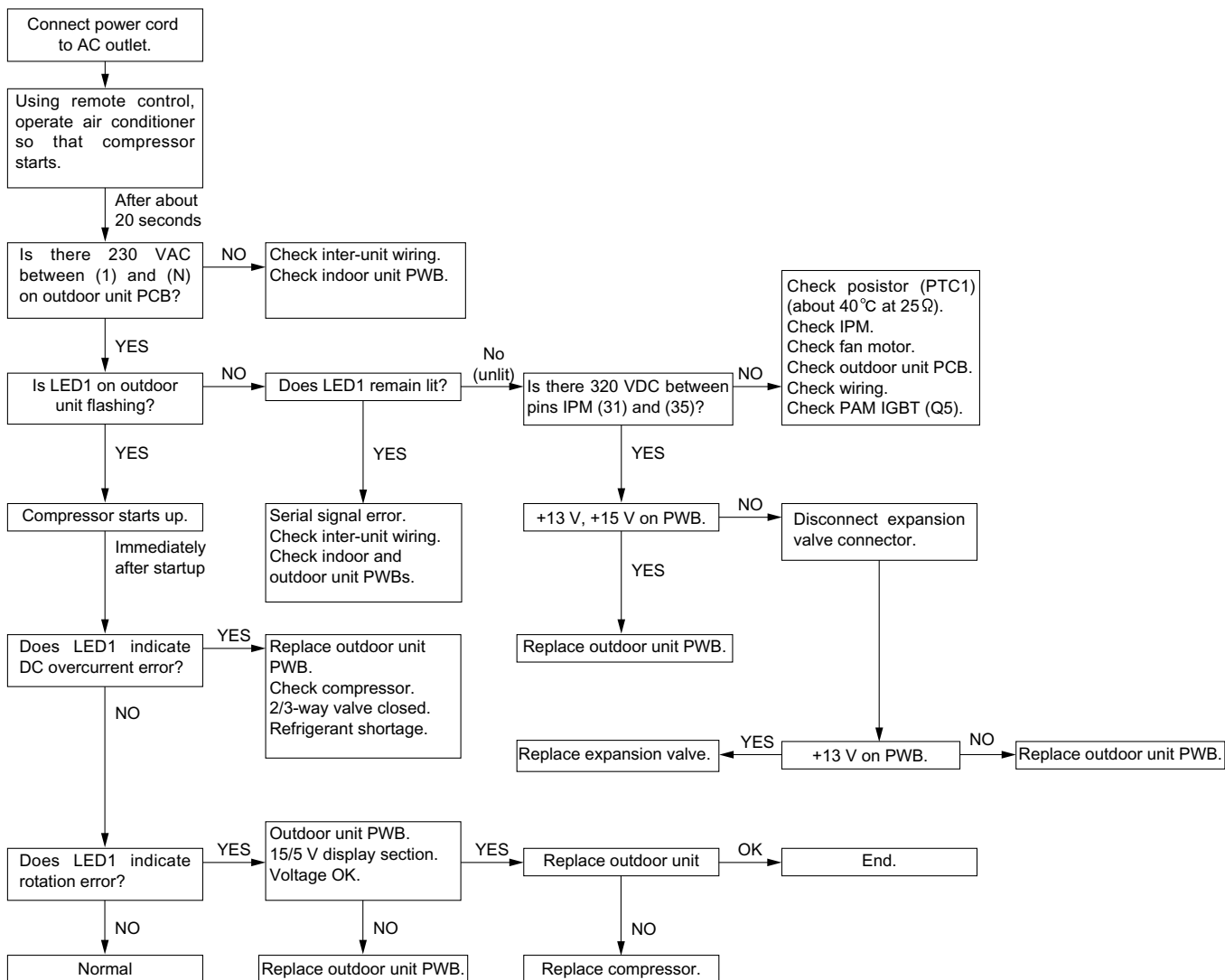

## 2. Procedure for determining defective expansion valve

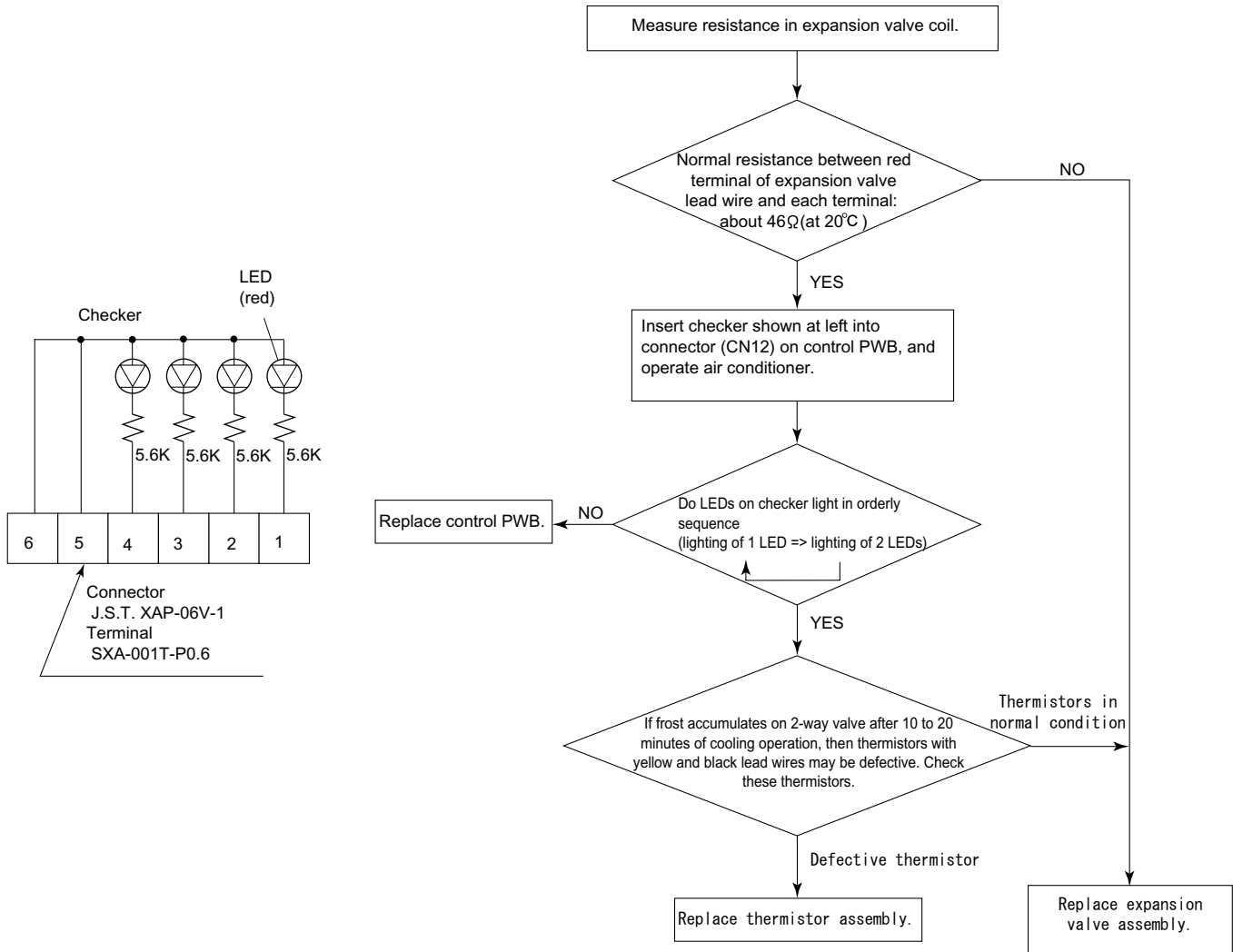

## 3. Diode bridge check method

Turn off the power and let the inverter electrolytic capacitor (C9, C10) discharge completely. Then use a tester and check continuity. When using a digital tester, the (+) and (-) tester lead wires in the table must be reversed.

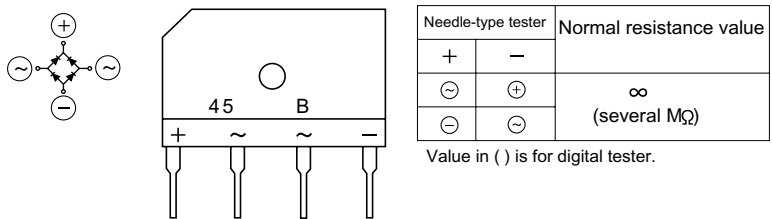

## 4. Inverter electrolytic capacitor (C9, C10) check method

Turn off the power, let the inverter electrolytic capacitor (C9, C10) discharge completely, and remove the capacitor from the control printed circuit board (PWB). First, check the case for cracks, deformation and other damages. Then, using a needle-type tester, check continuity.

Determination of normal condition
The tester needle should move on the scale and slowly returns to the original position. The tester needle should move in the same way when polarities are reversed. (When measurement is taken with the polarities reversed, the tester needle exceeds the scale range. Therefore, let the capacitor discharge before measurement.)

### 5. IPM check method

Turn off the power, let the large capacity electrolytic capacitor (C10) discharge completely, and dismount the IPM. Then, using a tester, check leak current between C and E.

When using a digital tester, the (+) and (-) tester lead wires in the table must be reversed.

Needle-type tester		Normal resistance value
(-)	(+)	
P	N	$\infty$ (several M $\Omega$ )
	U	
	V	
	W	

Needle-type tester		Normal resistance value
(-)	(+)	
U	N	$\infty$ (several M $\Omega$ )
V		
W		

Values in ( ) are for digital tester.

#### 5.1. IPM internal circuit diagram

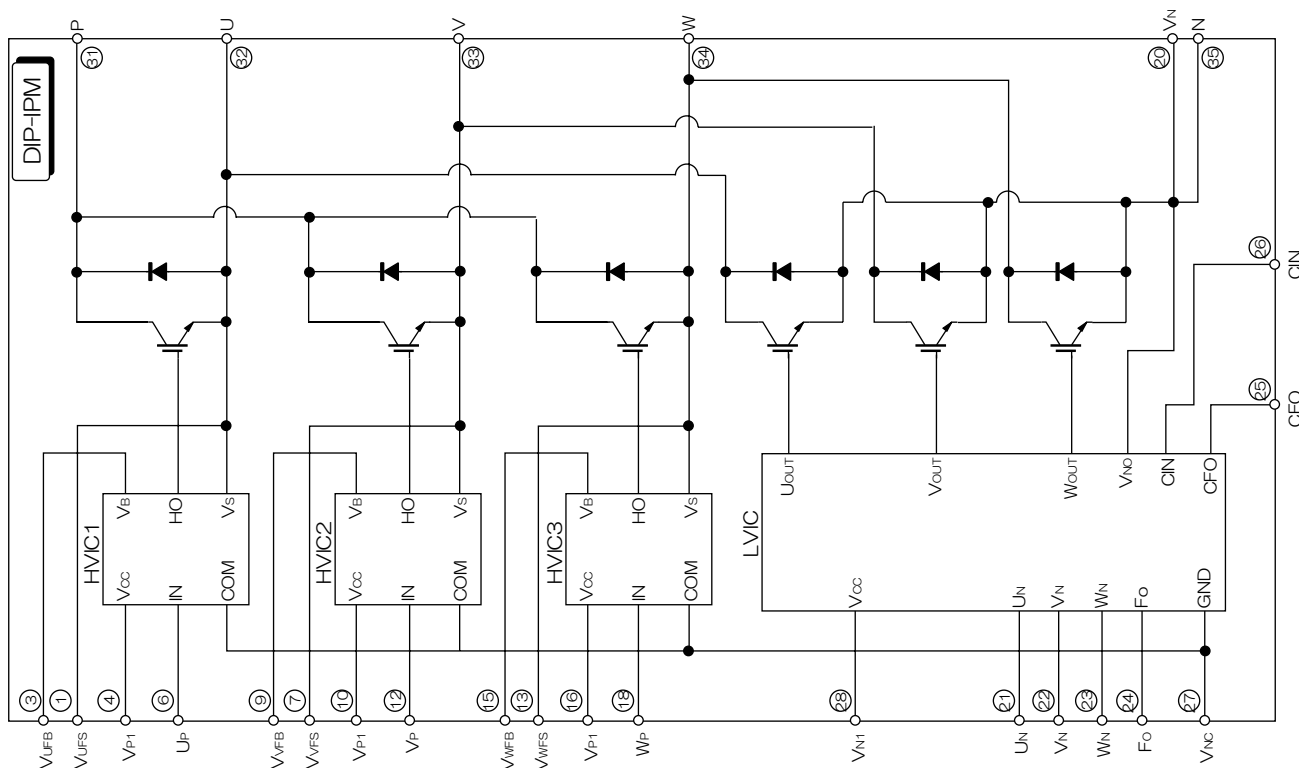

## [7] OUTDOOR UNIT CHECK METHOD

After repairing the outdoor unit, conduct the following inspection procedures to make sure that it has been repaired completely. Then, operate the compressor for a final operation check.

### 1. Checking procedures

No	Item	Check method	Normal value/condition	Remedy
1	Preparation	Disconnect compressor cords (white, orange, red: 3 wires) from compressor terminals, and connect simulated load (lamp used as load). Operate air conditioner in cooling or heating test operation mode.		
2	Inverter DC power supply voltage check	Measure DC voltage between IPM pins (31) and (35).	320 VDC	Replace control PWB. Replace diode bridge. Correct soldered section of Fasten tabs (T1, T2, T5 - T3) on control PWB and IMP (S, C, R). (Repair solder cracks.)
3	IPM circuit check	Check that 3 lamps (load) light. Check position detection voltage (+15 V, 5 V) on control PWB.	Each voltage should be normal. All 3 lamps (load) should light with same intensity.	Replace control PWB.

No	Item	Check method	Normal value/condition	Remedy
4	Compressor check	Measure compressor coil resistance (for each phase of U, V and W). Use multi-meter or digital tester capable of displaying two digits right of the decimal point (0.01Ω).	Resistance value at 20°C --- 0.65Ω	Correct connections at compressor terminals. Replace compressor.
5	Expansion valve check	Measure expansion valve coil resistance.	Each phase 46±3Ω (at 20°C)	Replace expansion valve.
6	Final check	Turn off power, and connect compressor cords to compressor. Operate air conditioner. Measure DC voltage between IPM pins (31) and (35).	Compressor should operate normally. 200 VDC or higher.	Replace control PWB. Replace outdoor unit thermistor. Replace compressor (in case of compressor lock).

**2. Troubleshooting of outdoor unit electric components**

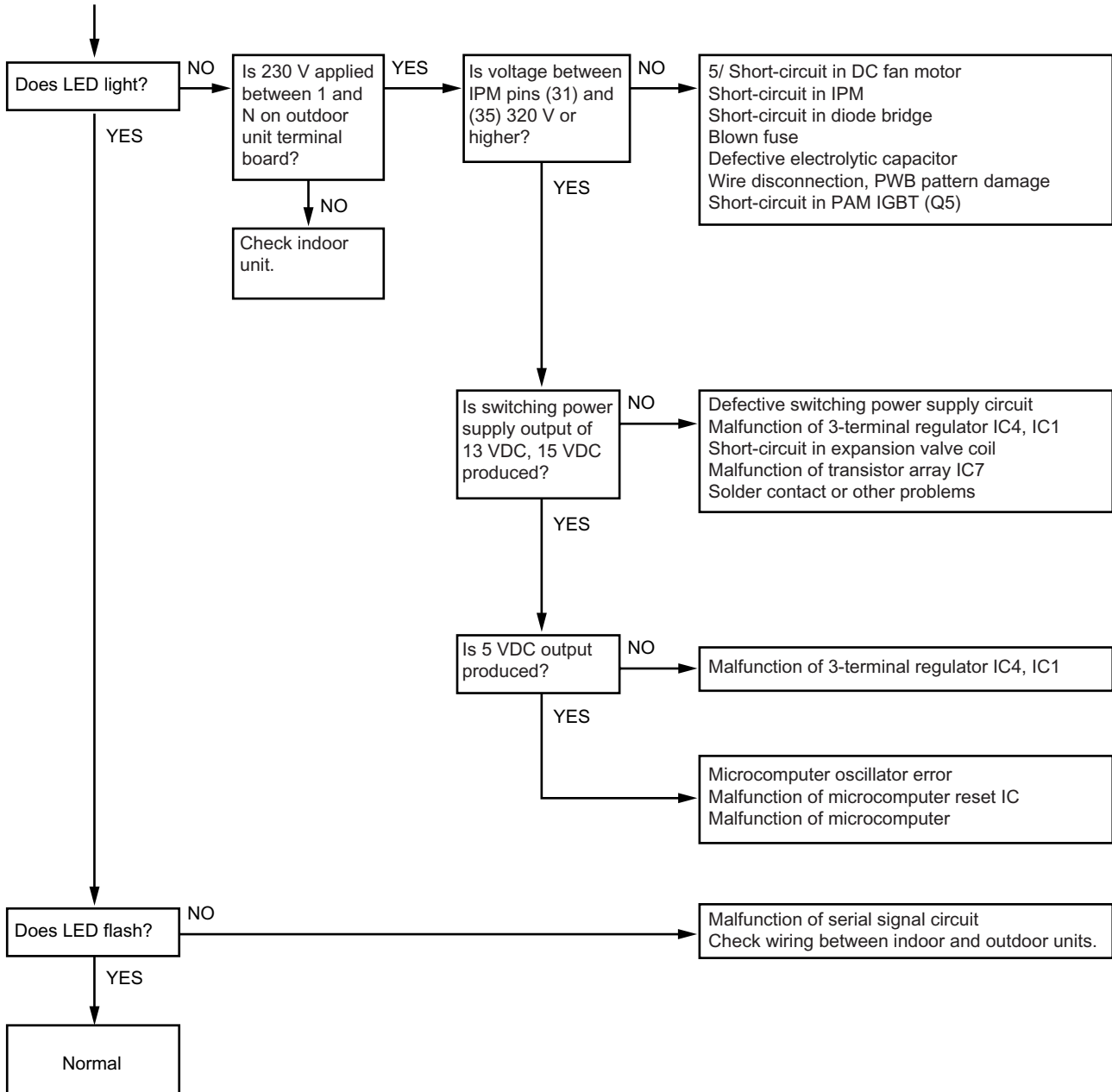

### 3. Caution in checking printed circuit boards (PWB)

#### 3.1. Non-insulated control circuit

The GND terminals of the low-voltage circuits (control circuits for microcomputer and thermistors and drive circuits for expansion valve and relays) on the control printed circuit board (PWB) are connected to the compressor drive power supply (320-VDC negative terminal). Therefore, exercise utmost caution to prevent electric shock.

If a measuring instrument used for the test is grounded, its chassis (ground) has the same electric potential as the 0-V probe. Since non-insulated circuits have the following voltage potential difference from the ground, connection of the grounding wire results in a short-circuit between the 0-V line and the ground, thus allowing an excessive current to flow to the tester to cause damage.

If the sheaths of the thermistor lead wires or expansion valve lead wires inside the outdoor unit become damaged due to pinching by the front panel or other metal parts or contacting a pipe, a high voltage can flow and destroy the circuits. To prevent these problems, carefully conduct assembly work.

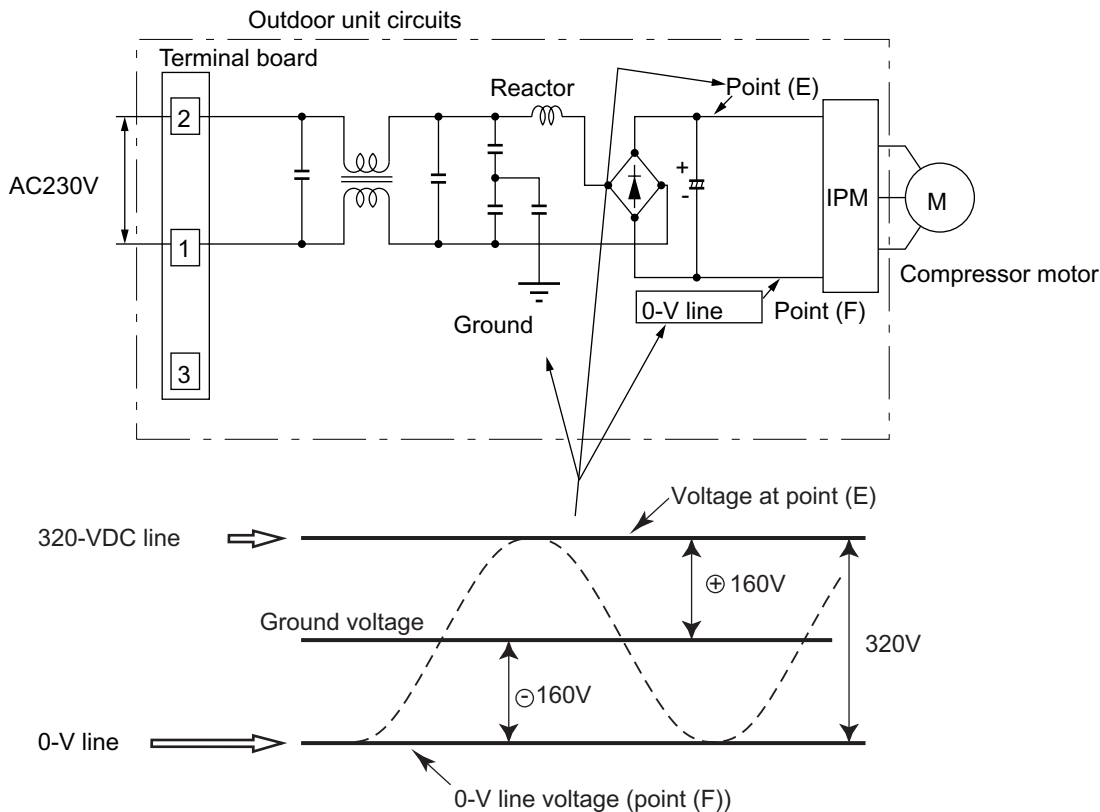

**Reason**

The oscilloscope (chassis ground) has the same electric potential as the 0-V probe. The entire electronic control section of the outdoor unit has a voltage potential difference from the ground as shown in the above diagram. When the oscilloscope is set up, the 0-V line and the ground voltage (ground) will be short-circuited, resulting in an excessive current flow to cause damage to the oscilloscope or indoor electric circuits.

## [8] TROUBLESHOOTING GUIDE

### 1. SELF-DIAGNOSIS FUNCTION AND DISPLAY MODE

1) To call out the content of the self-diagnosis memory, hold down the emergency operation button for more than five seconds when the indoor unit is not operating.

- a) According to the content of the self-diagnosis memory, the Operation LED (main category) and the Plasmacluster Ion LEDs (sub-category) flash in sync with the Timer LED on the indoor unit.
- b) In the event a complete shutdown occurs due to a malfunction, the Operation LED (green), Timer LED (yellow) and Plasmacluster Ion LED (blue) flash to indicate the general information of the generated malfunction.
- c) If the power cord is unplugged from the AC outlet or the circuit breaker is turned off, the self-diagnosis memory loses the stored data.

2) Display of detailed self-diagnosis result with main category and sub-category indications

When malfunction information is called out, the main category and sub-category of the self-diagnosis result are indicated by the Operation, Timer, and Plasmacluster Ion LEDs on the indoor unit.

\* 1: Example of self-diagnosis result displayed on indoor unit: Suction thermistor open-circuit error

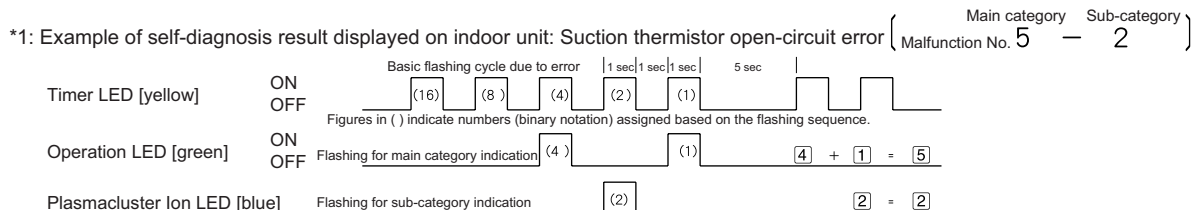

\* 2: The self-diagnosis display function of the outdoor unit indicates the error information by flashing LED1 on the outdoor unit according to the content of self-diagnosis.

The self-diagnosis display function of the outdoor unit is active only for about 3 to 10 minutes after self-diagnosis is performed during operation, and the display returns to normal condition after this display period.

The content of self-diagnosis cannot be called out by the self-diagnosis display function of the outdoor unit.

Example of self-diagnosis display on outdoor unit : Compressor high-temperature abnormality

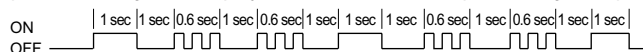

\* 3: The content of diagnosis is transferred to the indoor unit via serial communication, but it does not trigger a complete shutdown operation.

#### ATTENTION

Do not insert and pull out the outdoor unit DC Fan motor connector (CN3) during power on.

(It may result in damaging the Fan motor.)

[9] CHART

Malfuction diagnosis indications, descriptions, inspection methods and remedies

⊗ : Flashes in 2-sec intervals (normal) ● : On X : Off ○ : Flashes 3 times in 0.2-sec intervals

Status of indoor/outdoor units in operation	Indication by LED on outdoor unit	Indication by operation lamp on indoor unit		Malfunction No.		Content of diagnosis		Inspection location/method	Remedy	
		Lighting pattern at the time of timer lamp lighting	→ Off for 5 seconds	Main category	Sub category	Main category	Sub-category			
Indoor/outdoor units in complete shutdown	⊗ Normal flashing		→ Off for 5 seconds	0	-0	Normal	Normal			
				1	-0	Outdoor unit thermostat short-circuit	Heat exchanger thermostat short-circuit error	(1) Measure resistance of the outdoor unit thermostat. (2) Check the lead wire of the outdoor unit thermostat for torn sheath and short-circuit. (3) No abnormality found in above inspections (1) and (2).	(1) Replace the outdoor unit thermostat assembly. (2) Replace the outdoor unit thermostat assembly. (3) Replace the outdoor unit control PWB assembly.	
					-1	Operation lamp Cluster lamp	Outdoor temperature thermostat short circuit error	Outdoor temperature thermostat short circuit error		
					-2	Operation lamp Cluster lamp	Suction thermostat short circuit error	Suction thermostat short circuit error		
					-3	Operation lamp Cluster lamp	2Way valve thermostat short circuit error.	2Way valve thermostat short circuit error.		
Indoor/outdoor units in complete shutdown	○ 2 time		→ Off for 5 seconds	2	-0	Cycle temperature	Compressor high temperature error	(1) Check the outdoor unit air outlet for blockage. (2) Check if the power supply voltage is 216V or higher at full power. (3) Check the pipe connections for refrigerant leaks. (4) Measure resistance of the outdoor compressor thermostat. (5) Check the expansion valve for proper operation.	(1) Ensure unobstructed air flow from the outdoor unit air outlet. (2) Connect power supply of proper voltage. (3) Charge the specified amount of refrigerant. (4) Replace the outdoor unit compressor thermostat assembly. (5) Replace the expansion valve coil, expansion valve or outdoor unit control PWB assembly.	
					-1	Operation lamp Cluster lamp	Temporary stop due to compressor discharge overheat *3	Temporary stop due to compressor discharge overheat *3	(Temporary stop for cycle protection)	
					-2	Operation lamp Cluster lamp	Temporary stop due to outdoor unit heat exchanger overheat *3	Temporary stop due to outdoor unit heat exchanger overheat *3	(Temporary stop for cycle protection)	
					-3	Operation lamp Cluster lamp	Temporary stop due to indoor unit heat exchanger overheat *3	Temporary stop due to indoor unit heat exchanger overheat *3	(Temporary stop for cycle protection)	
					-4	Operation lamp Cluster lamp	Temporary stop due to IPM overheat *3	Temporary stop due to IPM overheat *3	(Temporary stop for parts protection)	
Indoor unit in operation Outdoor unit in temporary stop	○ 3 time		→ Off for 5 seconds	3	-0	Dry operation	IPM high temperature error	(1) Measure resistance of the heat sink thermostat. (Temporary stop for cycle protection)	(1) Replace the heat sink thermostat.	
					-5	Operation lamp Cluster lamp	IPM high temperature error	IPM high temperature error	(Temporary stop for cycle protection)	
					-0	Operation lamp Cluster lamp	Temporary stop due to dehumidifying operation *3	Temporary stop due to dehumidifying operation *3	(Temporary stop for cycle protection)	

\*3: The content of diagnosis is transferred to the indoor unit via serial communication, but it does not trigger a complete shutdown operation. Number of repetition \*: No complete shutdown

⊗ : Flashes in 2-sec intervals (normal) ● : On ✕ : Off ○ : Flashes 3 times in 0.2-sec intervals

Status of indoor/outdoor units	Indication by LED on outdoor unit	Indication by operation lamp on indoor unit		Malfunction No.		Content of diagnosis		Inspection location/method	Remedy
		Lighting pattern at the time of timer lamp lighting	Lighting pattern at the time of timer lamp lighting	Main category	Sub category	Main category	Sub category		
Indoor/outdoor units in complete shutdown	○ 5 time		Operation lamp Cluster lamp Operation lamp Cluster lamp Operation lamp Cluster lamp Operation lamp Cluster lamp Operation lamp Cluster lamp	5	Sub category	-0	Outdoor unit thermistor short-circuit	Heat exchanger thermistor open-circuit error	(1) Check the connector of the outdoor unit thermistor for secure installation. (2) Measure resistance of the outdoor thermistor. (3) Check the lead wire of the outdoor unit thermistor. (4) Replace the outdoor unit thermistor assembly. (5) Replace the outdoor unit control PWB assembly.
						-1	Outdoor unit thermistor short-circuit	Outdoor temperature thermistor open circuit error	(1) Check the connector of the outdoor unit thermistor for secure installation. (2) Measure resistance of the outdoor thermistor. (3) Check the lead wire of the outdoor unit thermistor. (4) Replace the outdoor unit thermistor assembly. (5) Replace the outdoor unit control PWB assembly.
						-2	Outdoor unit thermistor short-circuit	Suction thermistor open-circuit error	(1) Check the connector of the outdoor unit thermistor for secure installation. (2) Measure resistance of the outdoor thermistor. (3) Check the lead wire of the outdoor unit thermistor. (4) Replace the outdoor unit thermistor assembly. (5) Replace the outdoor unit control PWB assembly.
						-3	Outdoor unit thermistor short-circuit	2-way valve thermistor open-circuit error	(1) Check the connector of the outdoor unit thermistor for secure installation. (2) Measure resistance of the outdoor thermistor. (3) Check the lead wire of the outdoor unit thermistor. (4) Replace the outdoor unit thermistor assembly. (5) Replace the outdoor unit control PWB assembly.
						-4	Outdoor unit thermistor short-circuit	Discharge thermistor open circuit error	(1) Check the connector of the outdoor unit thermistor for secure installation. (2) Measure resistance of the outdoor thermistor. (3) Check the lead wire of the outdoor unit thermistor. (4) Replace the outdoor unit thermistor assembly. (5) Replace the outdoor unit control PWB assembly.
Indoor/outdoor units in complete shutdown	○ 6 time		Operation lamp Cluster lamp Operation lamp Cluster lamp Operation lamp Cluster lamp Operation lamp Cluster lamp Operation lamp Cluster lamp	6	Sub category	-0	Outdoor unit DC	(1) IPM continuity check (2) Check the IPM and heat sink for secure installation. (3) Check the outdoor unit fan motor for proper rotation. (4) No abnormality found in above inspections (1) through (3). (5) No abnormality found in above inspections (1) through (4).	
						-1	Outdoor unit DC	IPM pin level error	(1) Check the IPM is attached correctly to the outdoor unit control PWB. (2) Check the outdoor unit fan motor for proper rotation. (3) Check the outdoor unit fan motor for proper rotation. (4) Replace the outdoor unit control PWB assembly. (5) Replace the compressor.
						-2	Outdoor unit DC	AC overcurrent error	(1) Check the IPM is attached correctly to the outdoor unit control PWB. (2) Check the outdoor unit fan motor for proper rotation. (3) Check the outdoor unit fan motor for proper rotation. (4) Replace the outdoor unit control PWB assembly. (5) Replace the compressor.
Indoor/outdoor units in complete shutdown	○ 7 time		Operation lamp Cluster lamp Operation lamp Cluster lamp Operation lamp Cluster lamp Operation lamp Cluster lamp Operation lamp Cluster lamp	7	Sub category	-0	Outdoor unit AC	(1) Check the outdoor unit air outlet for blockage. (2) Check the outdoor unit fan for proper rotation. (3) Check the outdoor unit fan for proper rotation. (4) Replace the outdoor unit control PWB assembly.	
						-1	Outdoor unit AC	AC overcurrent error in OFF status	(1) Check the outdoor unit air outlet for blockage. (2) Check the outdoor unit fan for proper rotation. (3) Check the outdoor unit fan for proper rotation. (4) Replace the outdoor unit control PWB assembly.
						-2	Outdoor unit AC	AC maximum current error	(1) Check the outdoor unit air outlet for blockage. (2) Check the outdoor unit fan for proper rotation. (3) Check the outdoor unit fan for proper rotation. (4) Replace the outdoor unit control PWB assembly.
Indoor/outdoor units in complete shutdown	○ 7 time		Operation lamp Cluster lamp Operation lamp Cluster lamp Operation lamp Cluster lamp Operation lamp Cluster lamp Operation lamp Cluster lamp	7	Sub category	-3	Outdoor unit AC	(1) Check if there is an open-circuit in the secondary winding of the current transformer of the outdoor unit control PWB. (2) Check if the refrigerant volume is abnormally low. (3) Check if the refrigerant flows properly.	

\*3: The content of diagnosis is transferred to the indoor unit via serial communication, but it does not trigger a complete shutdown operation. Number of repetition \*: No complete shutdown



⊗ : Flashes in 2-sec intervals (normal) ● : On ✕ : Off ○ : Flashes 3 times in 0.2-sec intervals

Status of indoor/outdoor units	Indication by LED on outdoor unit	Indication by operation lamp on indoor unit		Malfunction No.		Content of diagnosis		Inspection location/method	Remedy												
		Lighting pattern at the time of timer lamp lighting → Off for 5 seconds	→ On for 5 seconds	Main category	Sub category	Main category	Sub category														
Indoor/outdoor unit in complete shutdown	○ 9 time			9	Outdoor unit cooling/heating switchover	-0	Thermistor installation error or 4-way valve error	(1) Check to make sure outdoor unit thermistor TH2 (heat exchanger) and TH5 (2-way valve) are installed in correct positions. (2) Measure resistance of thermistor TH1 and TH5. (3) Check the 4-way valve for proper operation. (4) No abnormality found in above inspections (1) through (3).	(1) Correct the installation. (2) Replace the thermistor assembly. (3) Replace the 4-way valve. (4) Replace the outdoor unit control PWB assembly.												
											10	EEPROM error	-0	Torque control error	(1) Check if the refrigerant volume is abnormally low. (2) Check the 4-way valve for proper operation. (3) Check to see compressor type is correct.	(1) Change the specified amount of refrigerant. (2) Replace the 4-way valve. (3) Replace the compressor with correct.					
																		-4	Gas leak error	(1) Check to make sure outdoor unit thermistor TH2 (heat exchanger) or indoor unit thermistor TH2 (Heat exchange) is installed in correct positions. (2) Check if the refrigerant volume is abnormally low.	(1) Correct the installation. (2) Change the specified amount of refrigerant.
	11	Outdoor unit DC fan rotation error	-0	Outdoor unit DC fan rotation error	(1) Check the connector CN3 of the outdoor unit DC fan motor for secure installation. (2) Check outdoor unit DC fan motor for proper rotation. (3) Check fuse FU3. (4) Outdoor unit control PCB.	(1) Correct the installation. (2) Replace the outdoor unit fan motor. (3) Replace the outdoor unit control PCB assembly. (4) Replace the outdoor unit control PCB assembly.															
								13	DC compressor error	-0	Compressor start up error	(1) Check the colors (red, white, orange) of the compressor cords for proper connection. (PWB side, compressor side) (2) Check if the IPM terminal resistance values are uniform. (3) No abnormality found in above inspections (1) and (2). (4) No abnormality found in above inspections (1) through (3).	(1) Correct the installation. (U: Red, V: White, W: Orange) (2) Replace the outdoor unit control PWB assembly. (3) Replace the outdoor unit control PWB assembly. (4) Replace the compressor.								

\*3: The content of diagnosis is transferred to the indoor unit via serial communication, but it does not trigger a complete shutdown operation. Number of repetition \*: No complete shutdown

⊗ : Flashes in 2-sec intervals (normal) ● : On ✕ : Off ○ : Flashes 3 times in 0.2-sec intervals

Status of indoor/outdoor units	Indication by LED on outdoor unit	Indication by operation lamp on indoor unit		Malfunction No.		Content of diagnosis		Inspection location/method	Remedy
		Lighting pattern at the time of timer lamp lighting	Lighting pattern at the time of operation lamp lighting	Main category	Sub category	Main category	Sub category		
Indoor/outdoor units in complete shutdown	○ 14 time			14	-0	Outdoor unit PAM	PAM over voltage error Compressor rotation error. PAM clock error	(1) Check the AC power supply voltage for fluctuation. (2) No abnormality found in above inspection  (1) Check the PAM clock for proper input.	(1) Connect the connector. (2) Replace the active filter.  (1) Replace the outdoor unit control PWB assembly.
Indoor unit in operation Outdoor unit in temporary stop	●  ✕			17	-0 -1	Wires between units	Serial open circuit  Outdoor unit does not turn on due to erroneous wiring	(1) Check the wires between units. (2) Check voltage between Nos. 1 and 2 on the indoor/outdoor unit terminal boards.  (1) Check the wires between units. (2) Check the outdoor unit fuse.  (3) Check 15-V, 13-V and 5-V voltages on the PWB. Check resistance between IPM terminals. (4) Check pins No. 5 and 7 of connector CN3 of the outdoor unit fan motor for short-circuit. (5) Outdoor unit control PWB	(1) Connect stable power supply. (2) Replace the outdoor unit control PWB assembly.  (1) Correct the wiring. (2) Replace the fuse or outdoor unit control PWB assembly. (3) Replace the outdoor unit control PWB assembly.  (4) Replace the outdoor unit fan motor. (5) Replace the outdoor unit control PWB assembly.
Indoor unit in operation Outdoor unit in temporary stop	●			18	-0 -1	Wires between units	Serial short circuit  Erroneous serial wiring	(1) Check the wires between units.  (1) Check the wires between units.	(1) Correct the wiring.  (1) Correct the wiring.
Indoor/outdoor units in complete shutdown	✕			19	-0	Indoor unit fan	Indoor unit fan error	(1) Check the indoor unit fan motor for proper rotating operation. (Check for fan lock.) (2) Check the lead wire of the indoor unit fan motor for open-circuit. (3) Check CN1 of the indoor unit fan motor for secure installation. (4) No abnormality found in above inspections (1) through (3).	(1) Replace the indoor unit fan motor. (2) Replace the indoor unit fan motor. (3) Correct the installation of CN1 of the indoor unit fan motor. (4) Replace the indoor unit control PWB.
Indoor/outdoor units in complete shutdown	●			20	-0	Indoor unit control PWB	EEPROM data error	(1) Error in data read from the indoor unit EEPROM	(1) Replace the indoor unit control PCB.

\*3: The content of diagnosis is transferred to the indoor unit via serial communication, but it does not trigger a complete shutdown operation. Number of repetition \*: No complete shutdown

## CHAPTER 4. REFRIGERATION CYCLE

### [1] SCHEMATIC DIAGRAM

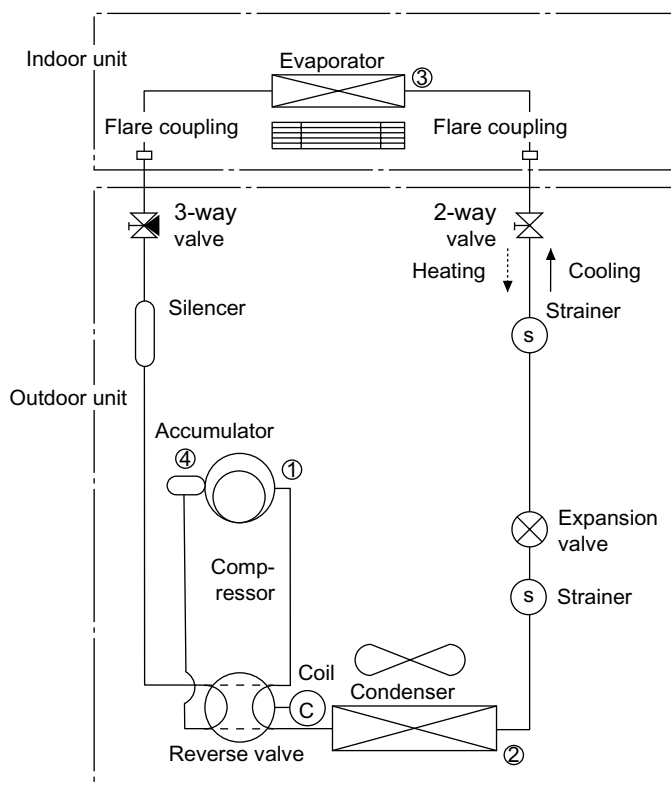

### [2] STANDARD CONDITION

	Indoor side		Outdoor side	
	Dry-bulb Temp. (°C)	Relative Humidity (%)	Dry-bulb Temp. (°C)	Relative Humidity (%)
Cooling	27	47	35	40
Heating	20	—	7	87

\* REFRIGERANT PIPE LENGTH 5m

### [3] TEMPERATURE AT EACH PART AND PRESSURE IN 3-WAY VALVE

Model	EHP6.0AA/I-O	
NO. Condition	Cooling	Heating
Temp. on ① (°C)	66	59
Temp. on ② (°C)	38	3
Temp. on ③ (°C)	13	25
Temp. on ④ (°C)	16	5
3-way valve pressure (MPaG)	1.0	2.2

\* On test run mode

### [4] PERFORMANCE CURVES

NOTE

- 1) Indoor fan speed: Hi
- 2) Vertical adjustment louver "front", Horizontal adjustment louver "level"
- 3) Indoor air temp. : Cooling 27°C, Heating 20°C
- 4) Power source : 230V, 50Hz
- 5) Compressor speed : Rated frequency

1. EHP6.0AA/I-O

1.1. At Cooling

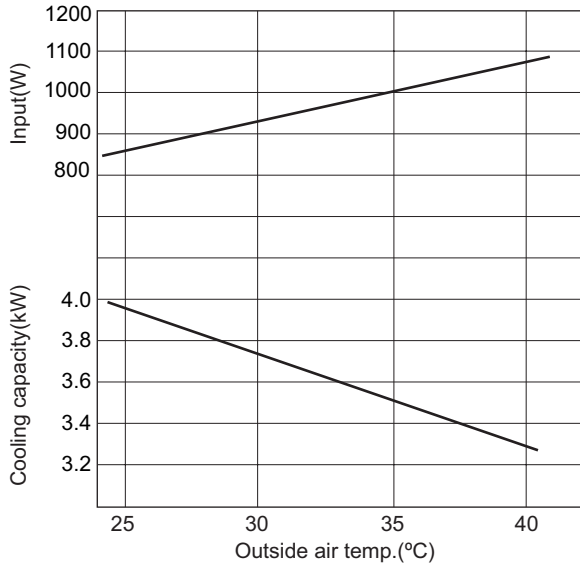

1.2. At Heating

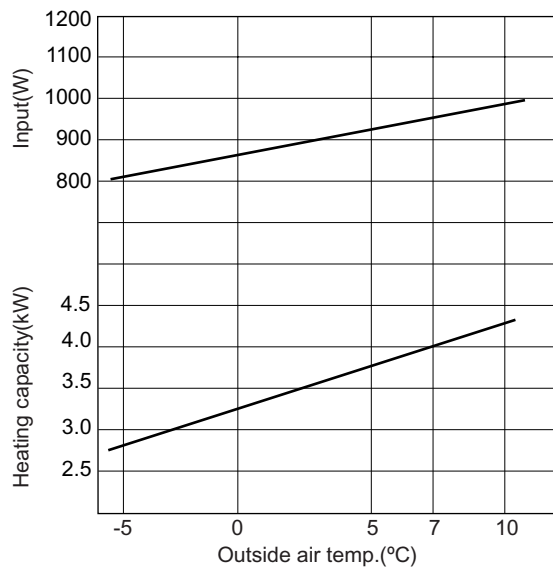

## CHAPTER 5. DISASSEMBLING PROCEDURE

If, in carrying out repairs and modifications, the work requires the use of arc- and flame-producing apparatus, such as welding, brazing and soldering equipment, this work shall only be started after the rooms have been thoroughly ventilated. While the work is being carried out, the mechanical ventilation, if any, shall be kept in constant operation and all windows and doors kept open. In the case of repairs to parts of the refrigerant circuit, it may be necessary that not only the workman but also a second person shall be present for observation and assistance.

Necessary protective equipment shall be available and, in the case of open flames or arcs, fire extinguishing apparatus shall be ready to hand.

Welding and brazing shall be carried out by qualified workmen.

### [1] INDOOR UNIT

- 1) Open the open panel.



- 2) Remove a screw fixing the cord holder.

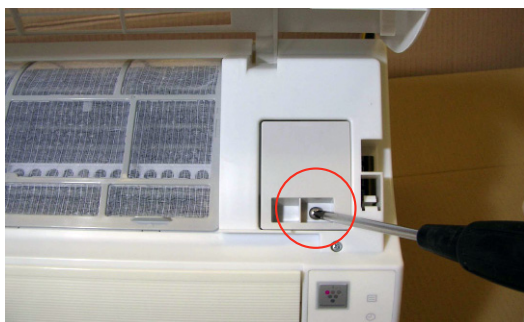

- 3) Remove the cord holder.

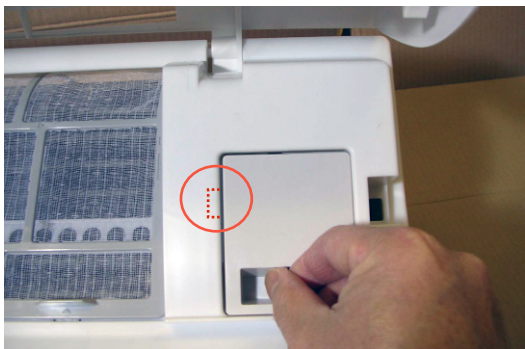

- 4) Loosen the screws on the terminal board and remove the Unite-to Unit wiring connected with the board.

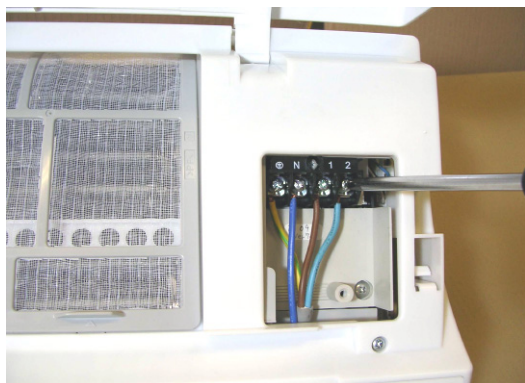

- 5) Slide out the 2 air filter.

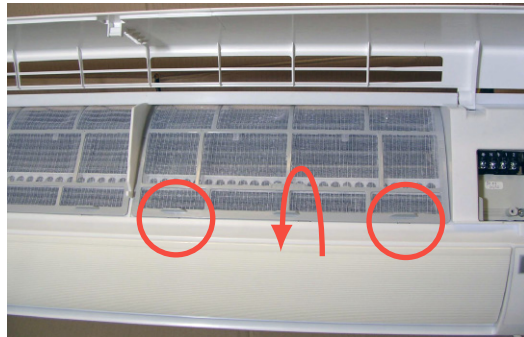

- 6) Remove 2 screws fixing the front panel.



- 7) Unfasten the front panel and pull forward it slightly. (5 circled spots in the picture are hooked.)

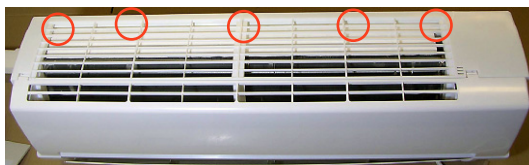

Open the horizontal louver.

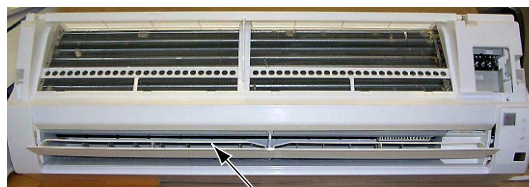

Horizontal louver



EHP6.0AA/I

Pull the front panel toward in the direction shown the picture.



- 8) Remove the thermistor cover and the thermistor wire.  
Remove a screw fixing the earth wire.

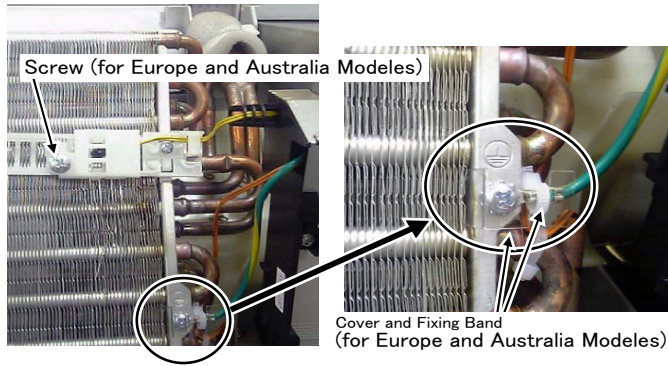

- 9) Unhook the A side of the control box cover from the control box and then unhook the B side in order to pull it away.

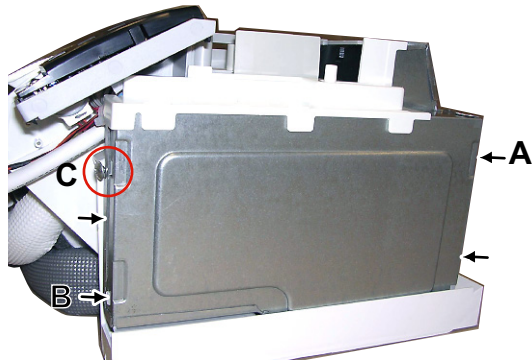

- 10) Remove the screw C fixing the control box and cut the wire fixing band.

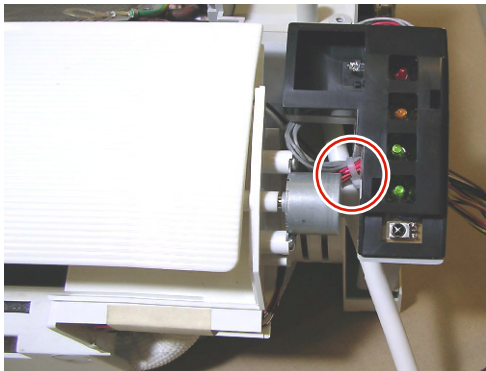

- 11) Remove the 5 connectors and remove the control box.

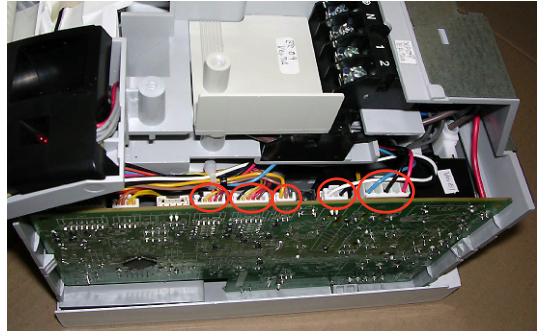

- 12) Remove the center shaft of the horizontal louver from louver holder with lifting the louver holder, and remove the horizontal louver from cabinet while warping.

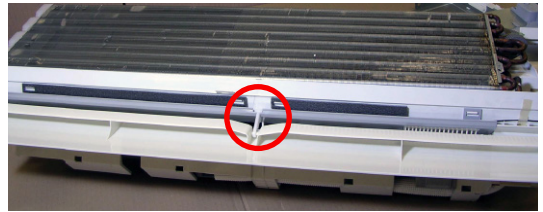
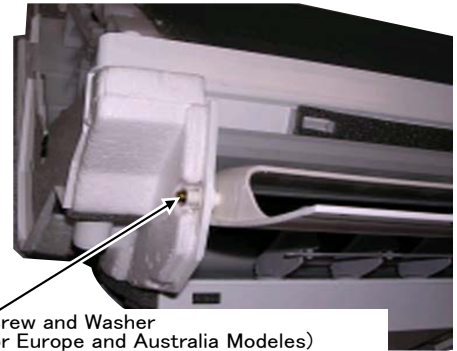

- 13) a) Remove the 3 screws fixing the side cover L and side cover R. Take off the catch of side cover R.

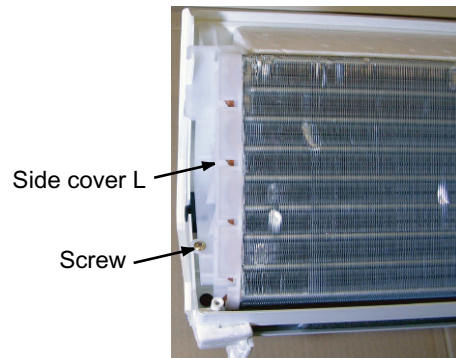

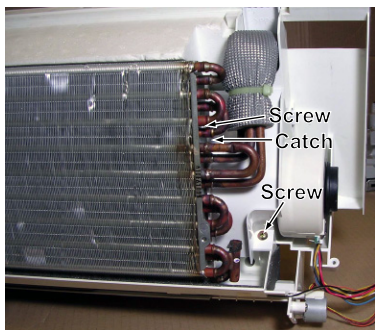

- b) Remove the tube cover.
  - Insert the (-) screwdriver to A hole and then lean it to the right as lifting B part.
- c) Remove the evaporator from the cabinet.
  - Take off the catch of the tube cover from the plate and move the evaporator upward.

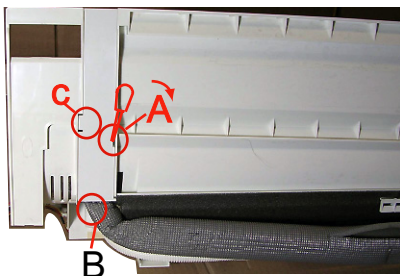

14) Lift the bottom part of the side cover R and remove the side cover R.

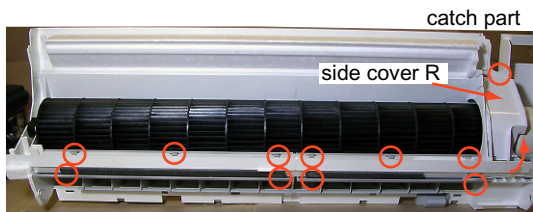

15) Loosen the screw of cross flow fan and separate the cross flow fan and the fan motor.

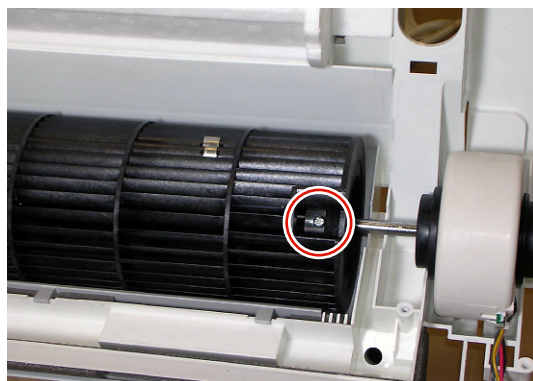

When assembling them, insert the motor shaft in the boss of the cross flow fan to the ring position.

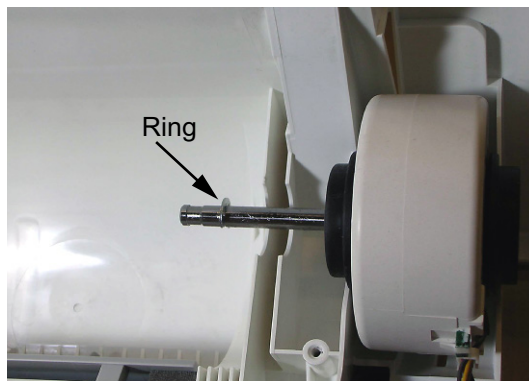

16) Take off the catch of guide R from cabinet and remove the guide.

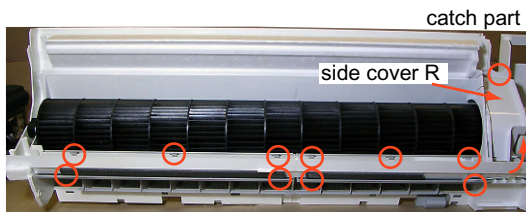

17) Remove the plasmacluster holder from the cover while taking off the both sides catches of the cover. (For the models with plasmacluster).

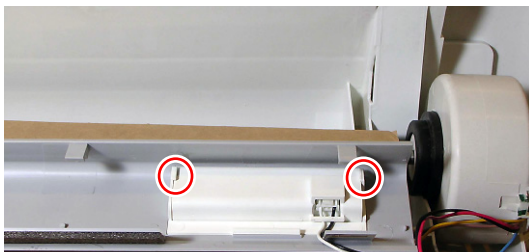

18) Take out the plasmacluster unit from the holder after taking off the catch of it. (For the models with plasmacluster)

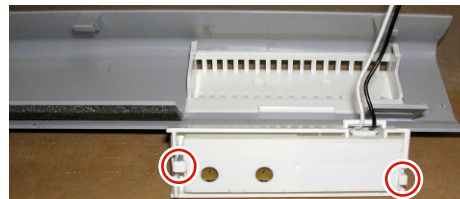

19) For the models with the auto horizontal adjustment function. Remove the 2 screws and take out the louver motor V assemblies.

- Remove the louver motor cover after taking off the catches of it.

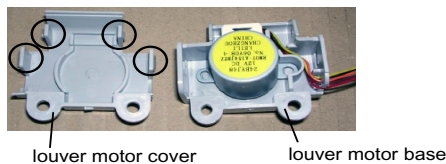
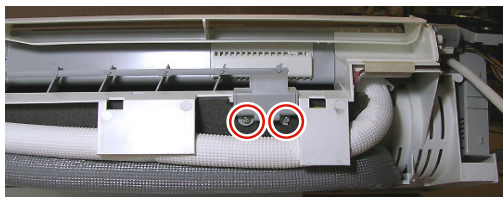



## [2] HOW TO REMOVE PLASMACLUSTER UNIT(For the models with PLASMACLUSTER)

1) Take the tape off and cut the fixing band

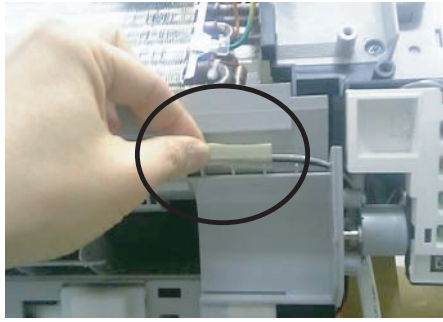

2) Insert the thin board to center of gap and remove the hook of holder.

Please be careful not to damage the lead wire.

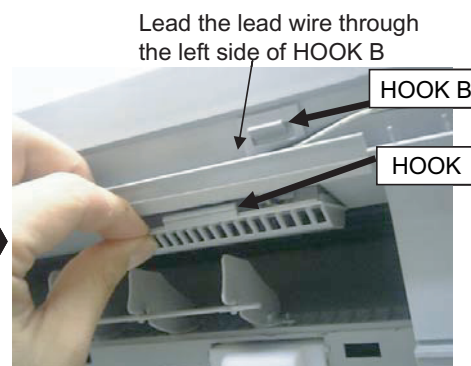

3) When assemble the plasmacluster unit,  
insert part A to holder part indicated by big arrow.

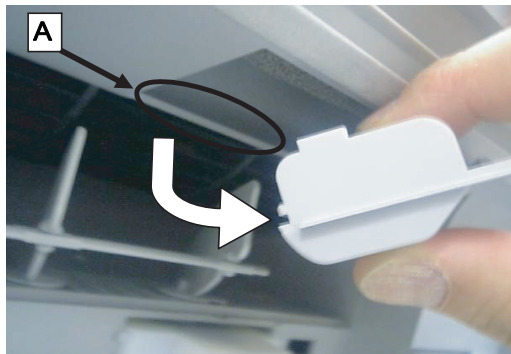



### [3] DISASSEMBLY OF OUTDOOR UNIT

1) The fixed screw of control box cover is removed and control box cover is removed.

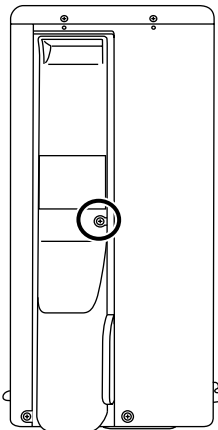

2) The 2 screws on the right-hand side of top plate ass'y is removed.

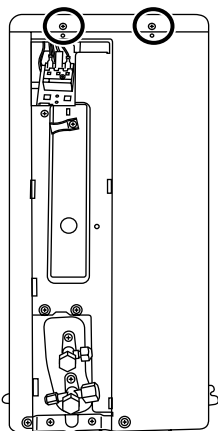

3) The 2 screws on the left-hand side of top plate ass'y is removed.

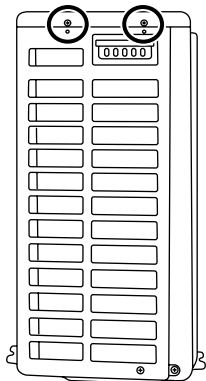

4) The screw on the right-hand side of front panel is removed

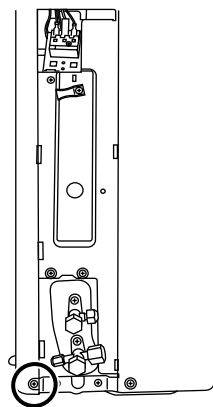

5) The screw on the right-hand side of front panel is removed

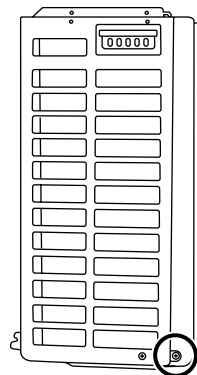

6) The 4 screws of the front of a front panel is removed.

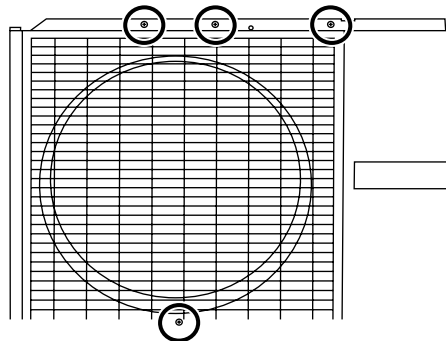

7) The 5 screws on the right-hand side of side cover R is removed.

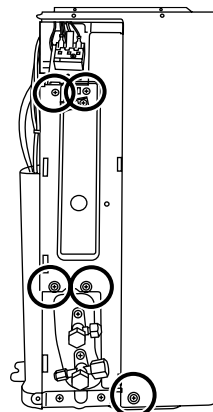

# EHP6.0AA/I

8) The 2 screws on the right-hand side of side cover L is removed.

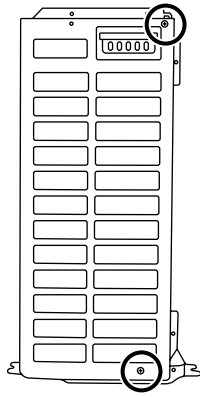

9) The 7 screws of the side cover L and side cover R back is removed.

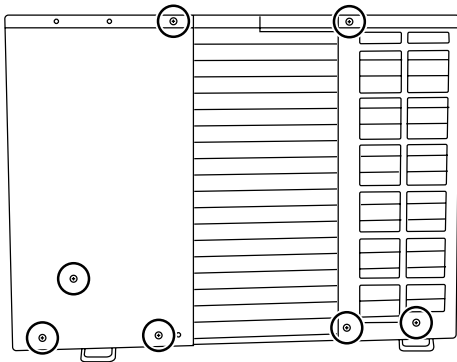

10)The connectors in the control box BOX and reactor is removed.

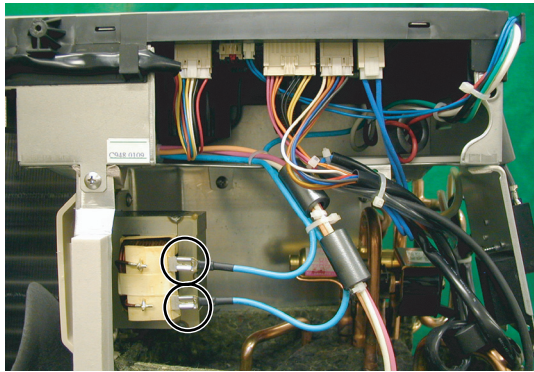

11)A control box BOX fixed 2 screws is removed.

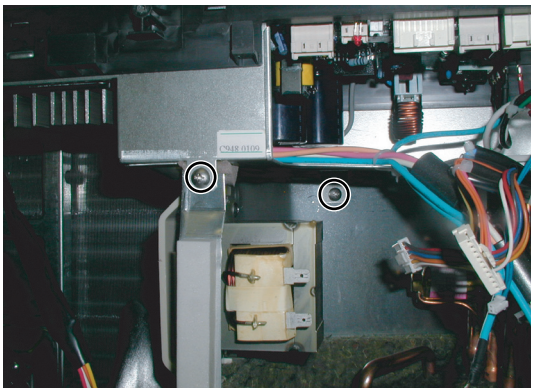

12)A bulkhead plate fixed 2 screws is removed.

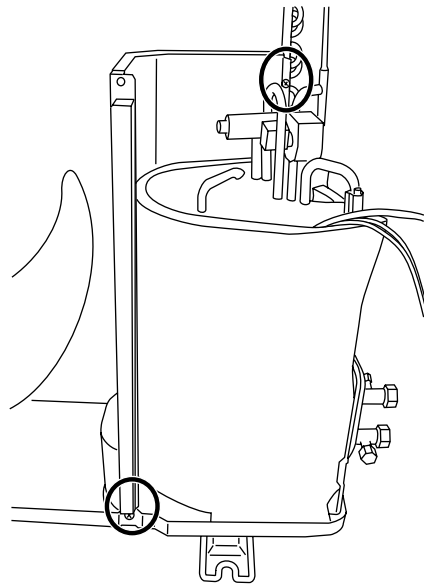

13)The comp cover top is removed.

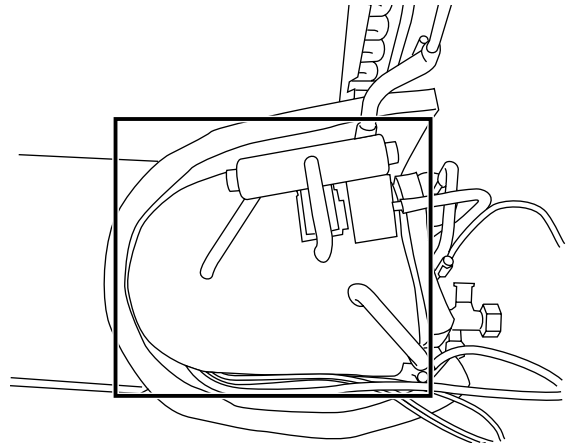

14)A nut is removed and a terminal cover is removed.

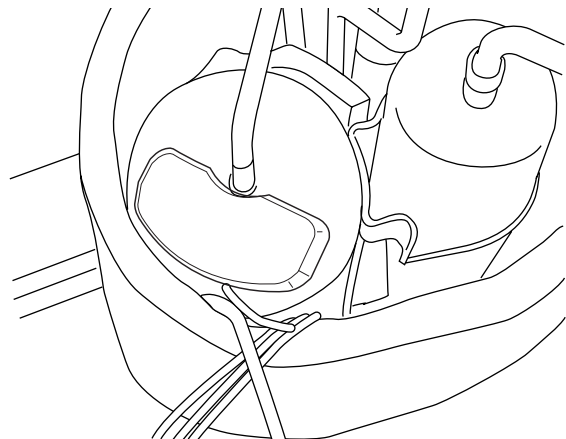

15) A lead wire, a thermistor, and a cover gasket are removed.

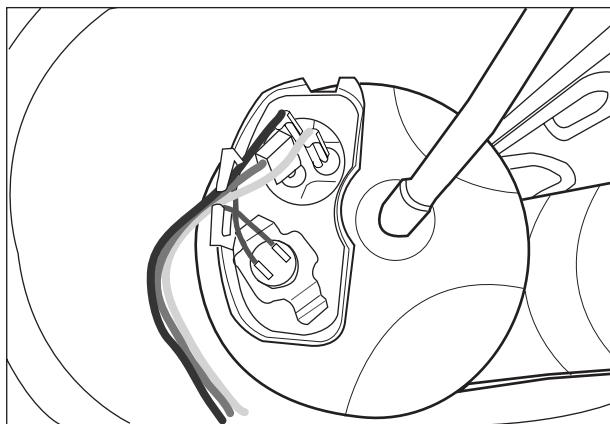

16) A comp cover is removed.

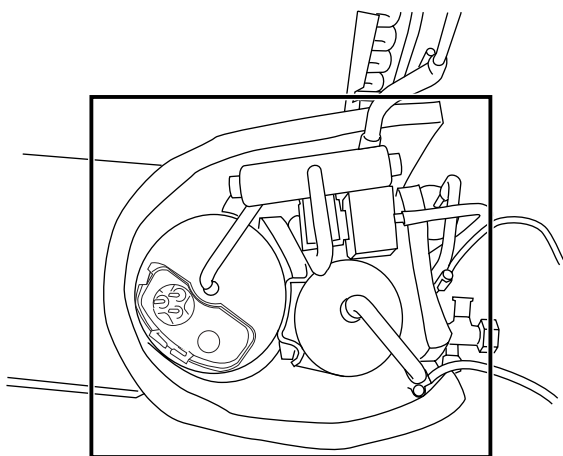

17) A thermistor is removed. (1 place)

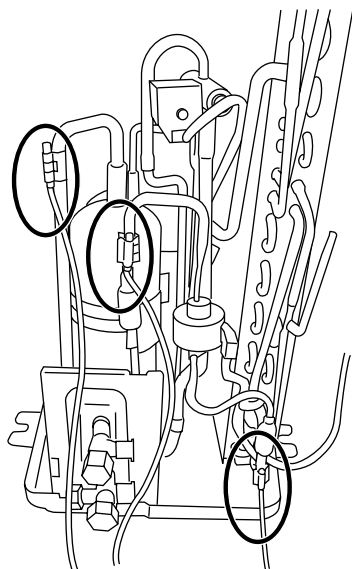

18) An outdoor fan is removed.

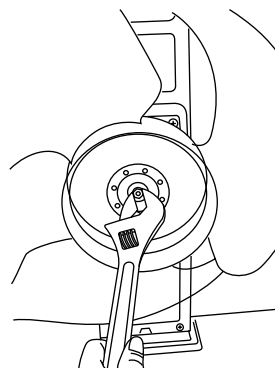

19) The fixed 2 screws of a motor angle is removed.

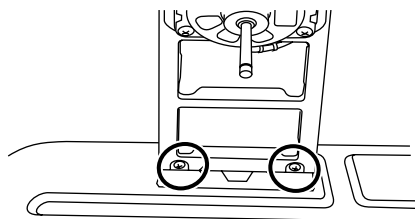

## EHP6.0AA/I

### - Disassembly of Heater(CHET-A025JBKZ) Unit

- 1) Cut the band fixing the bi-metal thermostat.
- 2) Powercord for bi-metal thermostat.

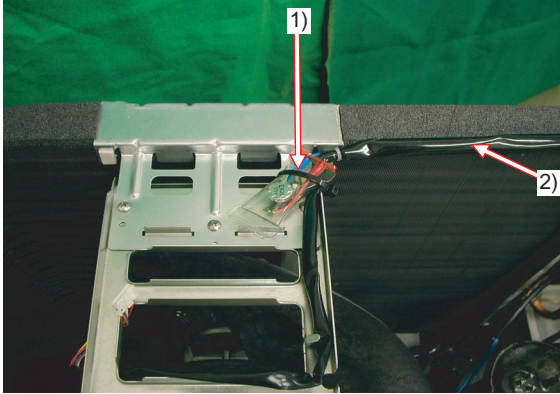

- 3) Cut the band which holds together the thermistor cords and power cord for bi-metal thermostat.
- 4) Remove screw NK-8K

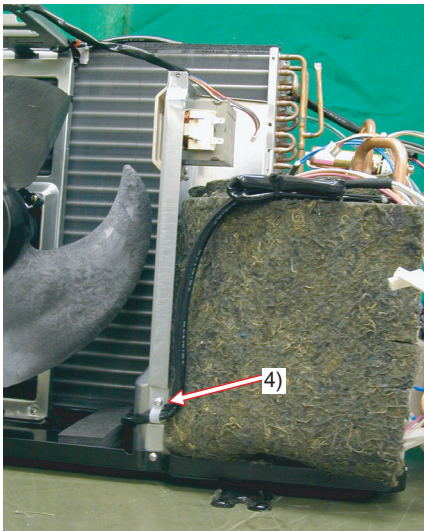

- 5) Pull out the heater wire from beneath the heat exchanger

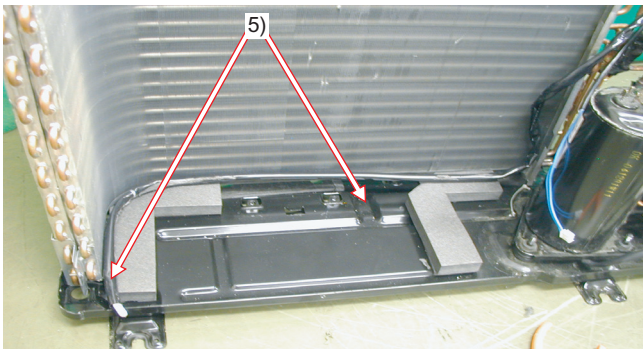





**BOSCH**

# PARTS GUIDE

## ROOM AIR CONDITIONERS

### MODEL

INDOOR UNIT **EHP6.0AA/I**  
OUTDOOR UNIT **EHP6.0AA/O**

---

### CONTENTS

- |                          |                           |
|--------------------------|---------------------------|
| [1] INDOOR UNIT PARTS    | [5] OTHER PARTS           |
| [2] ACCESSORY PARTS      | [6] OUTDOOR PACKING PARTS |
| [3] INDOOR PACKING PARTS | ■ INDEX                   |
| [4] OUTDOOR UNIT PARTS   |                           |

Parts marked with "△" are important for maintaining the safety of the set. Be sure to replace these parts with specified ones for maintaining the safety and performance of the set.

[1] INDOOR UNIT PARTS

EHP6.0AA/I

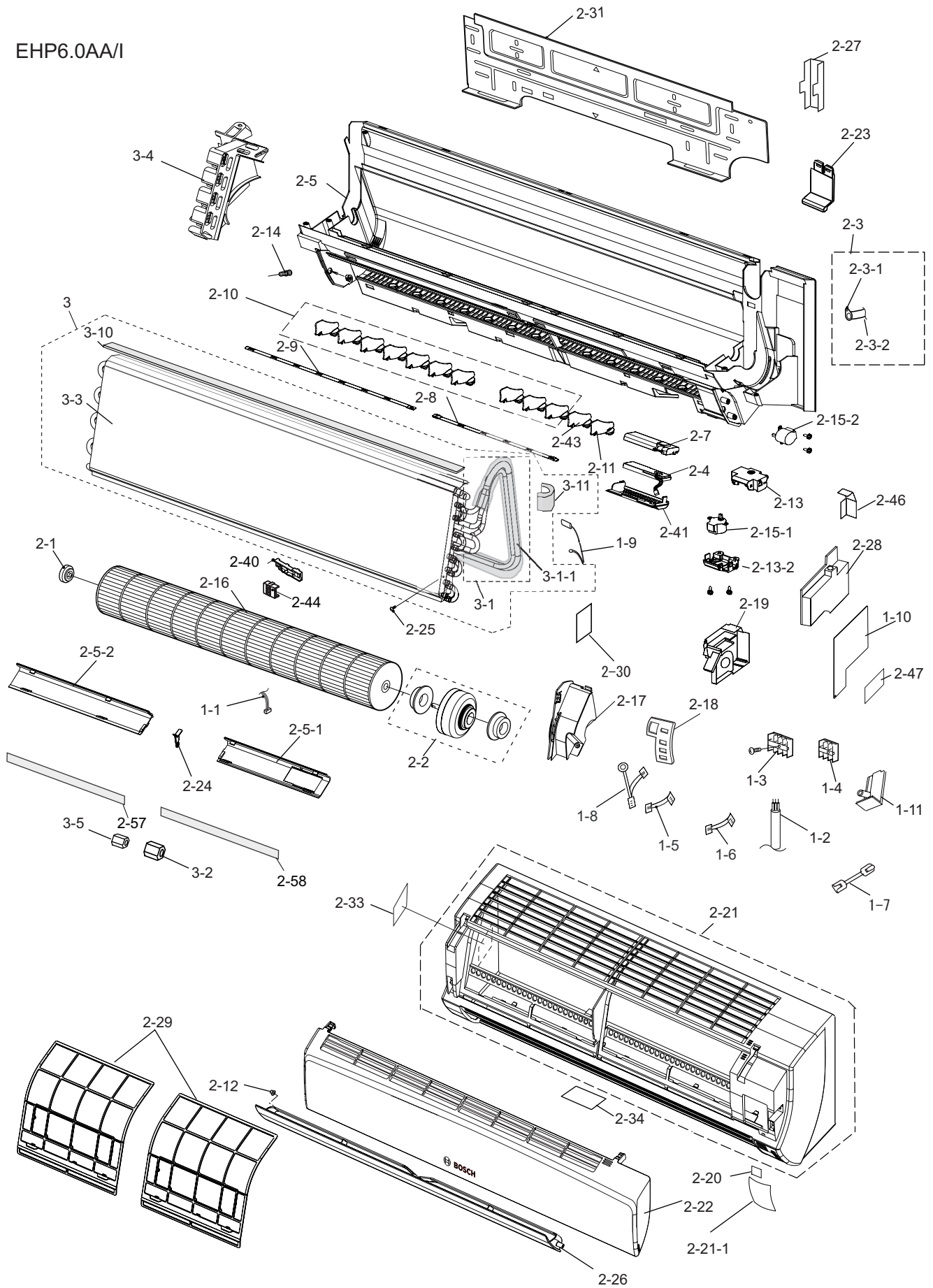



NO.	PARTS CODE	PRICE RANK	NEW MARK	PART RANK	DESCRIPTION
<b>[1] INDOOR UNIT PARTS</b>					
1-1	QW-VZF644JBZZ				LEAD WIRE PC
1-2	QACC-A341JBZZ				POWER SUPPLY CORD
1-3	QTANZA039JBZZ				TERMINAL BOARD
1-4	QTANZA040JBZZ				TERMINAL BOARD
1-5	QW-VZF891JBZZ				LEAD WIRE
1-6	QW-VZF895JBZZ				LEAD WIRE
1-7	QW-VZF896JBZZ				LEAD WIRE
1-8	QW-VZF897JBZZ				LEAD WIRE
1-9	RH-HXA070JBZZ				THERMISTOR
1-10	DSGY-C533JBKZ				CONTROL BOARD UNIT
1-11	LHLD-A875JBFA				AC CORD HOLDER
2-1	CHLD-A122JBKZ				BEARING ASS'Y
2-2	CMOT-A508JBKZ				FAN MOTOR SUB ASS'Y
2-3	CHOS-A032JBKZ				DRAIN HOSE ASS'Y
2-3-1	LPLT-A058JBPZ				HOSE HOLDER
2-3-2	PHOS-A052JBEZ				DRAIN HOSE
2-4	CKITTA108AKKZ				PLASMA CLUSTER UNIT
2-5	DSRA-A295JBKZ				CABINET SUB ASS'Y
2-5-1	PSTB-A002JBFA				GUIDE R
2-5-2	PSTB-A003JBFA				GUIDE L
2-7	LHLD-A848JBFA				HOLDER
2-8	MJNTPA134JBFA				LOUVER LINK R
2-9	MJNTPA135JBFA				LOUVER LINK L
2-10	MLOV-A462JBFA				VERTICAL LOUVER A1
2-11	MLOV-A463JBFA				VERTICAL LOUVER A2
2-12	NBRG-A026JBFP				LOUVER BUSHING
2-13	PDAI-A200JBFZ				LOUVER MOTOR BASE
2-13-2	PDAI-A209JBFZ				LOUVER MOTOR COVER
2-14	PGUMMA381JBEZ				DRAIN PLUG
2-15-1	RMOT-A154JBZZ				LOUVER MOTOR V
2-15-2	RMOT-A155JBZZ				LOUVER MOTOR H
2-16	NFANCA113JBEZ				CROSS FLOW FAN
2-17	PPLT-A540JBFZ				SIDE COVER R
2-18	LHLD-A857JBFA				LED HOLDER
2-19	PBOX-A511JBFZ				CONTROL BOX
2-20	PGIDMA052JBFZ				LED GUIDE
2-21	DWAK-A975JBKZ				FRONT PANEL ASS'Y
2-21-1	HDECQA240JBEA				DISPLAY PANEL
2-22	HPNL-B004JBFA				OPEN PANEL
2-23	LHLD-A858JBFZ				TUBE HOLDER
2-24	LHLD-A859JBFA				LOUVER HOLDER
2-25	LX-BZA075JBE0				SPECIAL SCREW
2-26	MLOV-A472JBRA				HORIZONTAL LOUVER
2-27	PCOV-B361JBFA				TUBE COVER
2-28	DCOV-A291JBKZ				CONTROL COVER ASS'Y
2-29	PFILMA236JBEA				AIR FILTER
2-30	TLAB-D456JBEZ				ENERGY LABEL
2-31	PPLTNA105JBWZ				MOUNTING ANGLE
2-33	TLABCC496JBRZ				WIRING DIAGRAM
2-34	TSPC-G264JBRA				NAME LABEL
2-40	LHLD-A500JBFZ				THERMISTOR HOLDER
2-41	PCOV-B400JBFA				CLUSTER COVER
2-43	MLOV-A493JBFA				VERTICAL LOUVER A3
2-44	PCOV-A300JBF0				THERMO HOLDER COVER
2-46	PCOV-B437JBWZ				CONTROL BOX COVER
2-47	PSHE-A268JBEZ				PROTECT SHEET
2-57	PSEL-D111JBEZ				SEAL
2-58	PSEL-D112JBEZ				SEAL R
3	CCYC-C270JBKZ				CYCLE ASS'Y
3-1	CPICB208JBKZ				TUBE ASS'Y
3-1-1	PFFPPD645JBEZ				TUBE INSULATOR
3-2	PSEN-A068JBKZ				FLARE NUT ASS'Y
3-3	DEVA-A344JBKZ				EVAPORATOR SUB ASS'Y
3-4	PPLT-A541JBFZ				SIDE COVER L
3-5	PSEN-A067JBKZ				FLARE NUT ASS'Y
3-10	PFFPPD317JBEZ				EVAPORATOR SEAL
3-11	PGUMSA046JBE0				DAMPER RUBBER

**[2] ACCESSORY PARTS**

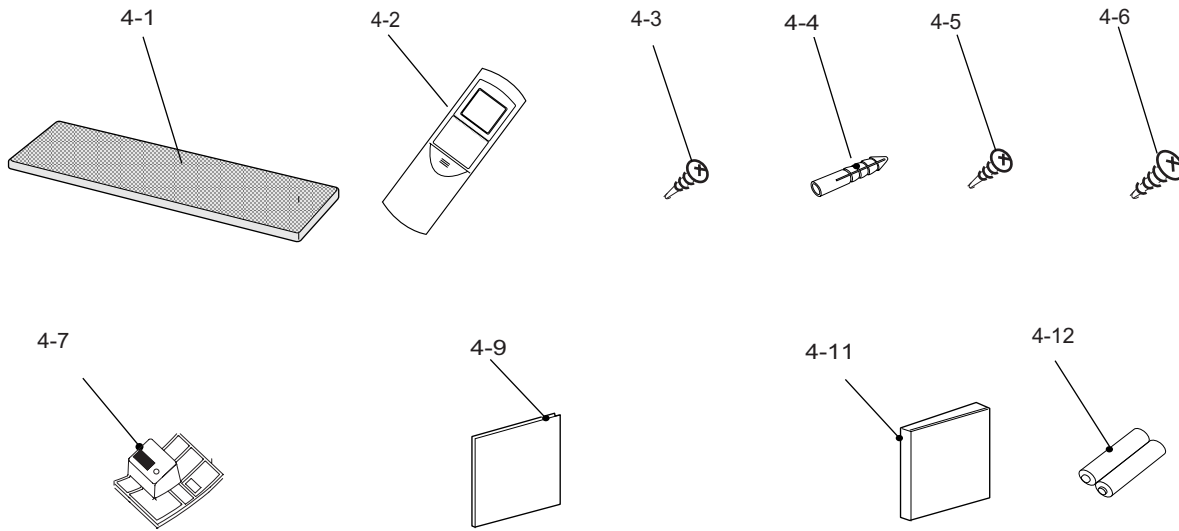

NO.	PARTS CODE	PRICE RANK	NEW MARK	PART RANK	DESCRIPTION
<b>[2] ACCESSORY PARTS</b>					
4-1	CFiL-A124JBKZ				PURIFY FILTER ASS'Y
4-2	GRMC-A765JBEZ				REMOTE CONTROL
4-3	LX-BZA357JBEZ				SPECIAL SCREW
4-4	LX-NZA207JBEZ				SPECIAL NUT
4-5	XTTS740P20000				TAPPING SCREW
4-6	XTTS745P30000				TAPPING SCREW
4-7	LHLD-A849JBFA				CORD HOLDER
4-9	TiNS-B164JBRZ				INSTALLATION MANUAL
4-11	TiNSEA566JBRZ				OPERATION MANUAL
4-12	UBATUA027JBE0				BATTERY PACK

**[3] INDOOR PACKING PARTS**

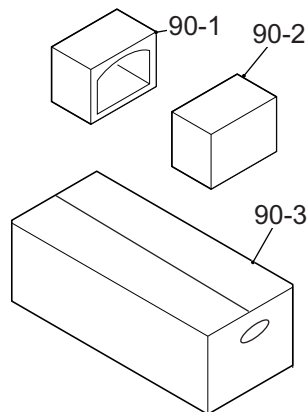

NO.	PARTS CODE	PRICE RANK	NEW MARK	PART RANK	DESCRIPTION
<b>[3] INDOOR PACKING PARTS</b>					
90-1	SPADBA471JBEZ				PACKING PAD L
90-2	SPADBA472JBEZ				PACKING PAD R
90-3	SPAKCC549JBEZ				PACKING CASE

# [4] OUTDOOR UNIT PARTS

EHP6.0AA/0

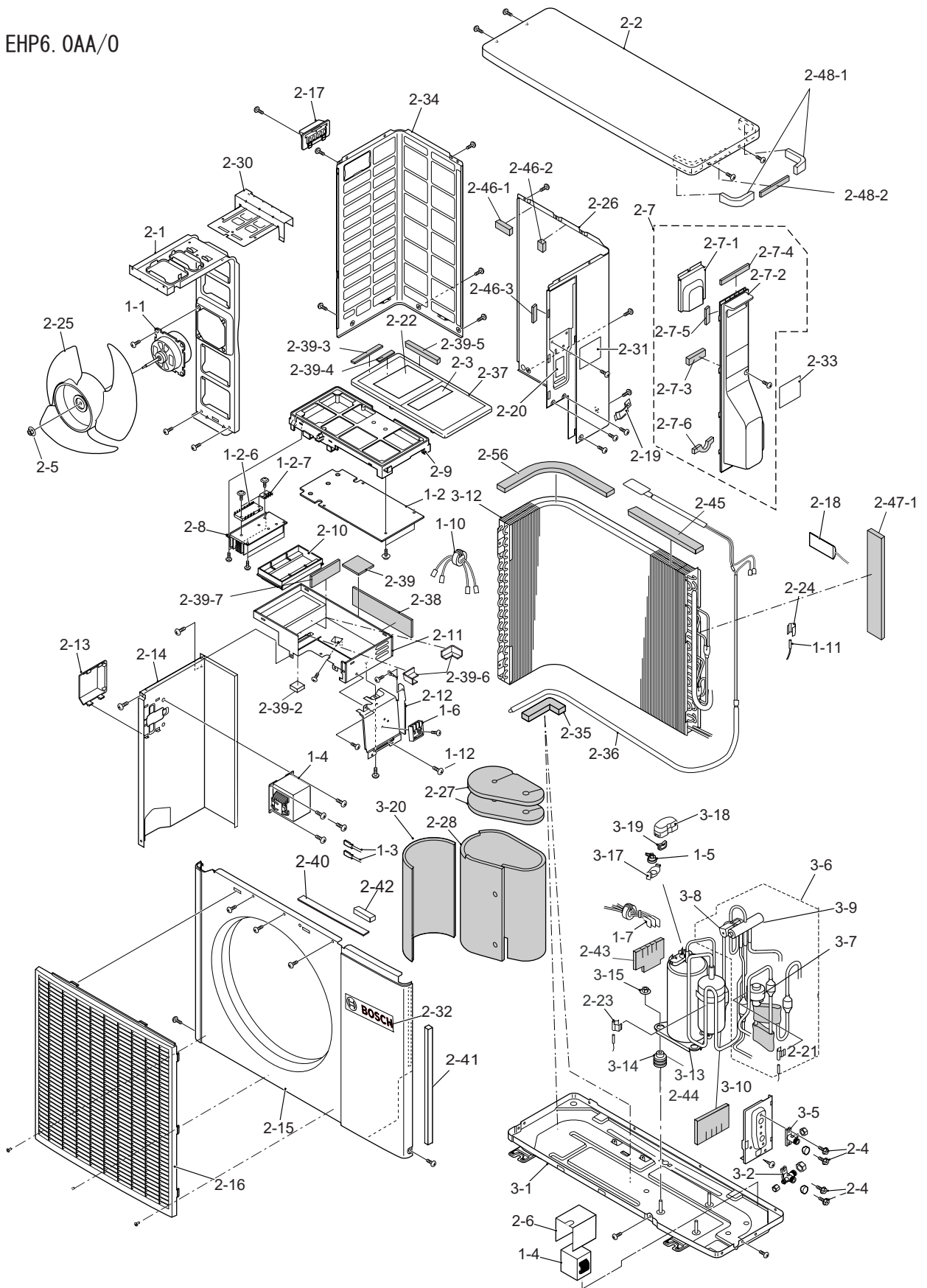

NO.	PARTS CODE	PRICE RANK	NEW MARK	PART RANK	DESCRIPTION
<b>[4] OUTDOOR UNIT PARTS</b>					
1-1	CMOTLB078JBEZ				FAN MOTER
1-2	DSGY-C331JBKZ				CONTROL BOARD UNIT
1-2-6	RH-iXA903JBZZ				IPM
1-2-7	VHDRBV2506+-F				DIODE BRIDGE
1-3	QW-VZF245JBZZ				LEAD WIRE(REACTOR)
1-4	RCiLZA009JBZZ				REACTOR
1-5	RTHM-A022JBE0				THERMISTOR
1-6	QTANZA001JBZZ				TERMINAL BOARD
1-7	FW-VZA070JBKZ				WIRE
1-10	RFiL-A064JBE0				FERRITE CORE
1-11	RH-HXA029JBZZ				THERMISTOR ASS'Y
1-12	LX-BZA075JBE0				SPECIAL SCREW
2-1	LANGKA157JBPZ				MOTOR ANGLE
2-2	CCAB-A408JBKZ				TOP PLATE ASS'Y
2-3	TLABCC310JBRZ				WIRING DIAGRAM
2-4	LX-BZA355JBEZ				SPECIAL SCREW
2-5	LX-NZA312JBEZ				SPECIAL NUT
2-6	LANG-A504JBYZ				REACTOR ANGLE
2-7	CFTA-A268JBKZ				COVER
2-7-1	PCOV-A594JBPZ				TERMINAL COVER
2-7-2	PFTA-A090JBFA				COVER
2-7-3	PSEL-C025JBEZ				SEAL
2-7-4	PSEL-C225JBEZ				SEAL B
2-7-5	PSEL-C116JBEZ				SEAL A
2-7-6	PSEL-C157JBEZ				SEAL
2-8	PRDAFA191JBEZ				HEAT SINK
2-9	LHLD-A684JBFA				HOLDER
2-10	LHLD-A685JBFA				HOLDER
2-11	DBOX-A049JBWZ				CONTROL BOX ASS'Y
2-12	PDAi-A187JBWZ				TERMINAL HOLDER
2-13	PCOV-A595JBFZ				COVER
2-14	PSKR-A284JBPZ				BULKHEAD
2-15	GCAB-A220JBTA				FRONT PANEL
2-16	GGADPA007JBFA				FAN GUARD
2-17	JHNDPA015JBFA				HANDLE
2-18	LHLD-A449JBF0				THERMISTOR HOLDER
2-19	LHLD-0079SRF0				CORD CLAMP
2-20	LHLD-A699JBFA				HOLDER BASE
2-21	MSPR-A026JBE0				SPRING
2-22	TLAB-C814JBRZ				LABEL
2-23	MSPR-A036JBE0				THERMISTOR SPRING
2-24	MSPR-A143JBEZ				SPRING
2-25	NFANPA118JBEZ				PROPELLER FAN
2-26	PPLT-A375JBTA				SIDE COVER R
2-27	PSPF-B004JBEZ				COMP COVER TOP
2-28	PSPF-B005JBEZ				COMPRESSOR COVER
2-30	CANG-A165JBKZ				HOLDER ASS'Y
2-31	TLAB-C511JBRA				LABEL
2-32	TLABBA257JBRA				BOSCH BADGE
2-33	TSPC-G265JBRZ				NAME LABEL
2-34	PPLT-A195JBTA				SIDE COVER L
2-35	PSEL-C830JBEZ				SEAL
2-36	CHET-A025JBKZ				HEATER ASS'Y
2-37	PCOV-A997JBWZ				COVER
2-38	PSEL-C685JBEZ				SEAL
2-39	PSEL-C686JBEZ				SEAL
2-39-2	PSEL-C769JBEZ				SEAL E
2-39-3	PSEL-C684JBEZ				SEAL A
2-39-4	PSEL-D053JBEZ				SEAL
2-39-5	PSEL-D052JBEZ				SEAL
2-39-6	PSEL-C345JBEZ				SEAL
2-39-7	PSEL-C767JBEZ				SEAL D
2-40	PSEL-C029JBEZ				SEAL A
2-41	PSEL-C222JBEZ				SEAL B
2-42	PSEL-C270JBEZ				SEAL
2-43	PFPFPD261JBEZ				INSULATOR
2-44	PFPFPD262JBEZ				INSULATOR
2-45	PSEL-C356JBEZ				CONDENSER SEAL
2-46-1	PSEL-C341JBEZ				SEAL C
2-46-2	PSEL-C340JBEZ				SEAL
2-46-3	PSEL-C339JBEZ				SEAL
2-47-1	PSEL-C342JBEZ				SEAL
2-48-1	PSEL-C338JBEZ				SEAL
2-48-2	PSEL-C337JBEZ				SEAL
2-56	PSEL-C030JBTA				CONDENSER SEAL
3-1	CCHS-A931JBTA				BASE PAN ASS'Y
3-2	DVLV-A857JBKZ				3WAY VALVE UNIT
3-5	DVLV-A757JBKZ				2WAY VALVE UNIT
3-6	CVLV-A913JBKZ				REVERSE VALVE ASS'Y
3-7	DVLV-A662JBKZ				CONTROL VALVE ASS'Y
3-8	CCiL-A142JBKZ				COIL ASS'Y
3-9	PVLVXA074JBEZ				REVERSE VALVE
3-10	PDAi-A123JBTA				FLARE COUPLING BASE
3-12	DCON-A330JBPZ				CONDENSER ASS'Y
3-13	FCMPRA204JBKZ				COMPRESSOR

NO.	PARTS CODE	PRICE RANK	NEW MARK	PART RANK	DESCRIPTION
<b>[4] OUTDOOR UNIT PARTS</b>					
3-14	GLEG-A149JBE0				COMPRESSOR CUSHION
3-15	LX-NZA313JBEZ				SPECIAL NUT
3-17	MSPR-A046JBE0				PROTECTOR SPRING
3-18	PCOV-A833JBEZ				TERMINAL COVER
3-19	PSEL-A142JBEZ				TERMINAL GASKET
3-20	PSPF-A977JBEZ				COMPRESSOR COVER
<b>[5] OTHER PARTS</b>					
1-2-1	QFS-CA001JBZZ				FUSE 20A 250V
1-2-2	QFS-GA051JBZZ				FUSE 2A 250V
1-2-3	QFS-GA052JBZZ				FUSE 3.15A 250V
1-2-4	QFS-CA002JBZZ				FUSE 15A 250V
1-2-5	QFS-GA064JBZZ				FUSE 1A 250V
2-50	PSEL-C345JBEZ				SEAL
2-51	PSEL-C684JBEZ				SEAL
2-52	PSEL-C767JBEZ				SEAL
2-53	PSEL-C769JBEZ				SEAL
3-7-1	RMOTSA023JBZZ				COIL

## [6] OUTDOOR PACKING PARTS

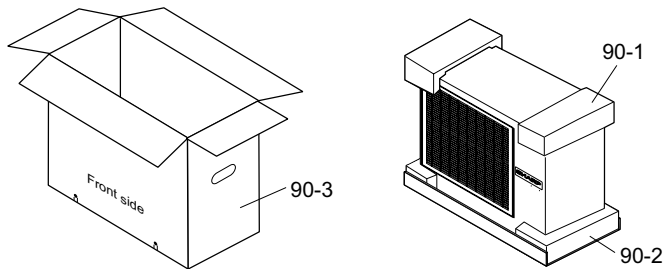

NO.	PARTS CODE	PRICE RANK	NEW MARK	PART RANK	DESCRIPTION
<b>[6] OUTDOOR PACKING PARTS</b>					
90-1	CPADBA048JBKZ				TOP PAD ASS'Y
90-2	CPADBA049JBKZ				BOTTOM PAD ASS'Y
90-3	SPAKCC550JBEZ				PACKING CASE

## INDEX

PARTS CODE	No.	PRICE RANK	NEW MARK	PART RANK
<b>【 C 】</b>				
CANG-A165JBKZ	4-2-30			
CCAB-A408JBKZ	4-2-2			
CCHS-A931JBTA	4-3-1			
CCIL-A142JBKZ	4-3-8			
CCYC-C270JBKZ	1-3			
CFIL-A124JBKZ	2-4-1			
CFTA-A268JBKZ	4-2-7			
CHET-A025JBKZ	4-2-36			
CHLD-A122JBKZ	1-2-1			
CHOS-A032JBKZ	1-2-3			
CKITTA108AKKZ	1-2-4			
CMOT-A508JBKZ	1-2-2			
CMOTLB078JBEZ	4-1-1			
CPADBA048JBKZ	6-90-1			
CPADBA049JBKZ	6-90-2			
CPiPCB208JBKZ	1-3-1			
CRMC-A765JBEZ	2-4-2			
CVLV-A913JBKZ	4-3-6			
<b>【 D 】</b>				
DBOX-A049JBWZ	4-2-11			
DCON-A330JBPZ	4-3-12			
DCOV-A291JBKZ	1-2-28			
DEVA-A344JBKZ	1-3-3			
DSGY-C331JBKZ	4-1-2			
DSGY-C533JBKZ	1-1-10			
DSRA-A295JBKZ	1-2-5			
DVLV-A662JBKZ	4-3-7			
DVLV-A757JBKZ	4-3-5			
DVLV-A857JBKZ	4-3-2			
DWAK-A975JBKZ	1-2-21			
<b>【 F 】</b>				
FCMPRA204JBKZ	4-3-13			
FW-VZA070JBKZ	4-1-7			
<b>【 G 】</b>				
GCAB-A220JBTA	4-2-15			
GGADPA007JBFA	4-2-16			
GLEG-A149JBE0	4-3-14			
<b>【 H 】</b>				
HDECQA240JBEA	1-2-21-1			
HPNL-B004JBJA	1-2-22			
<b>【 J 】</b>				
JHNDPA015JBFA	4-2-17			
<b>【 L 】</b>				
LANG-A504JBYZ	4-2-6			
LANGKA157JBPZ	4-2-1			
LHLD-0079SRF0	4-2-19			
LHLD-A449JBF0	4-2-18			
LHLD-A500JBFZ	1-2-40			
LHLD-A684JBFA	4-2-9			
LHLD-A685JBFA	4-2-10			
LHLD-A699JBFA	4-2-20			
LHLD-A848JBFA	1-2-7			
LHLD-A849JBFA	2-4-7			
LHLD-A857JBFA	1-2-18			
LHLD-A858JBFZ	1-2-23			
LHLD-A859JBFA	1-2-24			
LHLD-A875JBFA	1-1-11			
LPLT-A058JBPZ	1-2-3-1			
LX-BZA075JBE0	1-2-25			
"	4-1-12			
LX-BZA355JBEZ	4-2-4			
LX-BZA357JBEZ	2-4-3			
LX-NZA207JBEZ	2-4-4			
LX-NZA312JBEZ	4-2-5			
LX-NZA313JBEZ	4-3-15			
<b>【 M 】</b>				
MJNTPA134JBFA	1-2-8			
MJNTPA135JBFA	1-2-9			
MLOV-A462JBFA	1-2-10			
MLOV-A463JBFA	1-2-11			
MLOV-A472JBFA	1-2-26			
MLOV-A493JBFA	1-2-43			
MSPR-A026JBE0	4-2-21			
MSPR-A036JBE0	4-2-23			
MSPR-A046JBE0	4-3-17			
MSPR-A143JBEZ	4-2-24			
<b>【 N 】</b>				
NBRG-A026JBFP	1-2-12			

PARTS CODE	No.	PRICE RANK	NEW MARK	PART RANK
NFANCA113JBEZ	1-2-16			
NFANPA118JBEZ	4-2-25			
<b>【 P 】</b>				
Parts Code	0-Ref. No.			
PBOX-A511JBFZ	1-2-19			
PCOV-A300JBF0	1-2-44			
PCOV-A594JBPZ	4-2-7-1			
PCOV-A595JBFZ	4-2-13			
PCOV-A833JBEZ	4-3-18			
PCOV-A997JBWZ	4-2-37			
PCOV-B361JBFA	1-2-27			
PCOV-B400JBFA	1-2-41			
PCOV-B437JBWZ	1-2-46			
PDAi-A123JBTA	4-3-10			
PDAi-A187JBWZ	4-2-12			
PDAi-A200JBFZ	1-2-13			
PDAi-A209JBFZ	1-2-13-2			
PfiLMA236JBEA	1-2-29			
PFPPFD261JBEZ	4-2-43			
PFPPFD262JBEZ	4-2-44			
PFPPFD317JBEZ	1-3-10			
PFPPFD645JBEZ	1-3-1-1			
PFTA-A090JBFA	4-2-7-2			
PgiDMA052JBFZ	1-2-20			
PGUMMA381JBEZ	1-2-14			
PGUMSA046JBE0	1-3-11			
PHOS-A052JBEZ	1-2-3-2			
PPLT-A195JBTA	4-2-34			
PPLT-A375JBTA	4-2-26			
PPLT-A540JBFZ	1-2-17			
PPLT-A541JBFZ	1-3-4			
PPLTNA105JBWZ	1-2-31			
PRDAFA191JBEZ	4-2-8			
PSEL-A142JBEZ	4-3-19			
PSEL-C025JBEZ	4-2-7-3			
PSEL-C029JBEZ	4-2-40			
PSEL-C030JBEZ	4-2-56			
PSEL-C116JBEZ	4-2-7-5			
PSEL-C157JBEZ	4-2-7-6			
PSEL-C222JBEZ	4-2-41			
PSEL-C225JBEZ	4-2-7-4			
PSEL-C270JBEZ	4-2-42			
PSEL-C337JBEZ	4-2-48-2			
PSEL-C338JBEZ	4-2-48-1			
PSEL-C339JBEZ	4-2-46-3			
PSEL-C340JBEZ	4-2-46-2			
PSEL-C341JBEZ	4-2-46-1			
PSEL-C342JBEZ	4-2-47-1			
PSEL-C345JBEZ	4-2-39-6			
"	5-2-50			
PSEL-C356JBEZ	4-2-45			
PSEL-C684JBEZ	4-2-39-3			
"	5-2-51			
PSEL-C685JBEZ	4-2-38			
PSEL-C686JBEZ	4-2-39			
PSEL-C767JBEZ	4-2-39-7			
"	5-2-52			
PSEL-C769JBEZ	4-2-39-2			
"	5-2-53			
PSEL-C830JBEZ	4-2-35			
PSEL-D052JBEZ	4-2-39-5			
PSEL-D053JBEZ	4-2-39-4			
PSEL-D111JBEZ	1-2-57			
PSEL-D112JBEZ	1-2-58			
PSEN-A067JBKZ	1-3-5			
PSEN-A068JBKZ	1-3-2			
PSHE-A268JBEZ	1-2-47			
PSKR-A284JBPZ	4-2-14			
PSPF-A977JBEZ	4-3-20			
PSPF-B004JBEZ	4-2-27			
PSPF-B005JBEZ	4-2-28			
PSTB-A002JBFA	1-2-5-1			
PSTB-A003JBFA	1-2-5-2			
PVLVXA074JBEZ	4-3-9			
<b>【 Q 】</b>				
QACC-A341JBZZ	1-1-2			
QFS-CA001JBZZ	5-1-2-1			
QFS-CA002JBZZ	5-1-2-4			
QFS-GA051JBZZ	5-1-2-2			
QFS-GA052JBZZ	5-1-2-3			

PARTS CODE	No.	PRICE RANK	NEW MARK	PART RANK
QFS-GA064JBZZ	5-1-2-5			
QTANZA001JBZZ	4-1-6			
QTANZA039JBZZ	1-1-3			
QTANZA040JBZZ	1-1-4			
QW-VZF245JBZZ	4-1-3			
QW-VZF644JBZZ	1-1-1			
QW-VZF891JBZZ	1-1-5			
QW-VZF895JBZZ	1-1-6			
QW-VZF896JBZZ	1-1-7			
QW-VZF897JBZZ	1-1-8			
<b>【 R 】</b>				
RCiLZA009JBZZ	4-1-4			
RFiL-A064JBE0	4-1-10			
RH-HXA029JBZZ	4-1-11			
RH-HXA070JBZZ	1-1-9			
RH-iXA903JBZZ	4-1-2-6			
RMOT-A154JBZZ	1-2-15-1			
RMOT-A155JBZZ	1-2-15-2			
RMOTSA023JBZZ	5-3-7-1			
RTHM-A022JBE0	4-1-5			
<b>【 S 】</b>				
SPADBA471JBEZ	3-90-1			
SPADBA472JBEZ	3-90-2			
SPAKCC549JBEZ	3-90-3			
SPAKCC550JBEZ	6-90-3			
<b>【 T 】</b>				
TiNS-B164JBRZ	2-4-9			
TiNSEA566JBRZ	2-4-11			
TLABBA257JBRA	4-2-32			
TLAB-C511JBRA	4-2-31			
TLAB-C814JBRZ	4-2-22			
TLABCC310JBRZ	4-2-3			
TLABCC496JBRZ	1-2-33			
TLAB-D456JBEZ	1-2-30			
TSPC-G264JBRA	1-2-34			
TSPC-G265JBRZ	4-2-33			
<b>【 U 】</b>				
UBATUA027JBE0	2-4-12			
<b>【 V 】</b>				
VHDRBV2506+-F	4-1-2-7			
<b>【 X 】</b>				
XTTS740P20000	2-4-5			
XTTS745P30000	2-4-6			

