

# Service Manual

## Air Conditioner

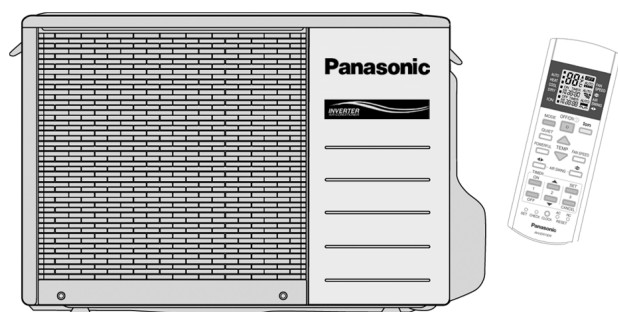

**CS-E9EKEB CU-E9EKEB**  
**CS-E12EKEB CU-E12EKEB**



### **⚠ WARNING**

This service information is designed for experienced repair technicians only and is not designed for use by the general public. It does not contain warnings or cautions to advise non-technical individuals of potential dangers in attempting to service a product. Products powered by electricity should be serviced or repaired only by experienced professional technicians. Any attempt to service or repair the product or products dealt with in this service information by anyone else could result in serious injury or death.

### **⚠ PRECAUTION OF LOW TEMPERATURE**

In order to avoid frostbite, be assured of no refrigerant leakage during the installation or repairing of refrigeration circuit.

## CONTENTS

	Page		Page
<b>1 Safety Precautions</b> .....	3	<b>6 Refrigeration Cycle Diagram</b> .....	13
<b>2 Specification</b> .....	5	<b>7 Block Diagram</b> .....	14
2.1. CS-E9EKEB CU-E9EKEB .....	5	<b>8 Wiring Diagram</b> .....	15
2.2. CS-E12EKEB CU-E12EKEB .....	7	8.1. CS-C9EKEB CS-C12EKEB .....	15
<b>3 Features</b> .....	9	8.2. CU-C9EKEB CU-C12EKEB .....	16
3.1. Super Air Purifying System with SUPER alleru-buster .....	9	<b>9 Printed Circuit Board</b> .....	17
3.2. Ion Freshener .....	9	9.1. Indoor Unit .....	17
3.3. Super Quiet .....	9	9.2. Outdoor Unit .....	19
3.4. Powerful Heating And Top-class Energy Efficiency .....	9	<b>10 Simplified Electronic Circuit Diagram</b> .....	21
<b>4 Location of controls and components</b> .....	10	10.1. Indoor Unit .....	21
4.1. Indoor Unit .....	10	10.2. Outdoor Unit .....	22
4.2. Outdoor Unit .....	10	<b>11 Installation Instructions</b> .....	23
4.3. Remote Control .....	10	11.1. Select The Best Location .....	23
<b>5 Dimension</b> .....	11	11.2. Indoor Unit .....	24
5.1. Indoor Unit & Remote Control .....	11	11.3. Outdoor Unit .....	27
5.2. Outdoor Unit .....	12		

<b>12 Operation And Control</b> .....	<b>30</b>	15.1. Indoor Electronic Controller and Control Board .....	41
12.1. Basic Function .....	30	15.2. Indoor Cross Flow Fan and Fan Motor .....	43
12.2. Protection Control .....	35	15.3. Outdoor Propeller Fan and Fan Motor .....	45
<b>13 Servicing Mode</b> .....	<b>37</b>	<b>16 Technical Data</b> .....	<b>47</b>
13.1. Auto Switch Operation .....	37	16.1. CS-E9EKEB CU-E9EKEB .....	47
13.2. Indicator Panel .....	37	16.2. CS-E12EKEB CU-E12EKEB .....	53
<b>14 Troubleshooting Guide</b> .....	<b>38</b>	16.3. Sensible Capacity Chart .....	58
14.1. Refrigeration Cycle System .....	38	<b>17 Exploded View And Replacement Parts List</b> .....	<b>59</b>
14.2. Relationship Between The Condition Of The Air Conditioner And Pressure And Electric Current .....	39	17.1. CS-E9EKEB CS-E12EKEB .....	59
14.3. Breakdown Self Diagnosis Function .....	39	17.2. CS-E9EKEB CS-E12EKEB .....	60
14.4. Error Codes Table .....	40	17.3. CU-E9EKEB CU-E12EKEB .....	61
<b>15 Disassembly and Assembly Instructions</b> .....	<b>41</b>	17.4. CU-E9EKEB CU-E12EKEB .....	62

# 1 Safety Precautions

- Read the following "SAFETY PRECAUTIONS" carefully before perform any servicing.
- Electrical work must be installed or serviced by a licensed electrician. Be sure to use the correct rating of the power plug and main circuit for the model installed.
- The caution items stated here must be followed because these important contents are related to safety. The meaning of each indication used is as below.

Incorrect installation or servicing due to ignoring of the instruction will cause harm or damage, and the seriousness is classified by the following indications.





 <b>WARNING</b>	This indication shows the possibility of causing death or serious injury.
--	---

 <b>CAUTION</b>	This indication shows the possibility of causing injury or damage to properties.
--	--

- The items to be followed are classified by the symbols:

	This symbol denotes item that is PROHIBITED from doing.
---	---

- Carry out test running to confirm that no abnormality occurs after the servicing. Then, explain to user the operation, care and maintenance as stated in instructions. Please remind the customer to keep the operating instructions for future reference.

 <b>WARNING</b>	
1. Engage dealer or specialist for installation and servicing. If installation or servicing done by the user is defective, it will cause water leakage, electrical shock or fire.	
2. Install according to this installation instruction strictly. If installation is defective, it will cause water leakage, electrical shock or fire.	
3. Use the attached accessories parts and specified parts for installation and servicing. Otherwise, it will cause the set to fall, water leakage, fire or electrical shock.	
4. Install at a strong and firm location which is able to withstand the set's weight. If the strength is not enough or installation is not properly done, the set will drop and cause injury.	
5. For electrical work, follow the local national wiring standard, regulation and the installation instruction. An independent circuit and single outlet must be used. If electrical circuit capacity is not enough or defect found in electrical work, it will cause electrical shock or fire.	
6. Use the specified cable and connect tightly for indoor/outdoor connection. Connect tightly and clamp the cable so that no external force will be acted on the terminal. If connection or fixing is not perfect, it will cause heat-up or fire at the connection.	
7. Wire routing must be properly arranged so that control board cover is fixed properly. If control board cover is not fixed perfectly, it will cause heat-up at connection point of terminal, fire or electrical shock.	
8. When connecting the piping, do not allow air or any substances other than the specified refrigerant to enter the refrigeration cycle. Otherwise, this may lower the capacity, cause abnormally high pressure in the refrigeration cycle, and possibly result in explosion and injury.	
9. Thickness of copper pipes used must be more than 0.8 mm. Never use copper pipes thinner than 0.8 mm.	
10. It is desirable that the amount of residual oil is less than 40 mg/10 m.	
11. Do not modify the length of the power supply cord or use of the extension cord, and do not share the single outlet with other electrical appliances. Otherwise, it will cause fire or electrical shock.	

 **CAUTION**

1. The equipment must be earthed. It may cause electrical shock if grounding is not perfect.
2. Do not install the unit at place where leakage of flammable gas may occur. In case gas leaks and accumulates at surrounding of the unit, it may cause fire.



3. Carry out drainage piping as mentioned in installation instructions. If drainage is not perfect, water may enter the room and damage the furniture.
4. Pb free solder has a higher melting point than standard solder; typically the melting point is 50 - 70°F (30 - 40°C) higher. Please use a high temperature soldering iron. In case of the soldering iron with temperature control, please set it to 700 ± 20°F (370 ± 10°C). Pb free solder will tend to splash when heated too high (about 1100°F/600°C).



**ATTENTION**

1. Selection of the installation location. Select an installation location which is rigid and strong enough to support or hold the unit, and select a location for easy maintenance.
2. Power supply connection to the air conditioner. Connect the power supply cord of the air conditioner to the mains using one of the following methods. Power supply point shall be the place where there is ease for access for the power disconnection in case of emergency.  
In some countries, permanent connection of this room air conditioner to the power supply is prohibited.
  1. Power supply connection to the receptacle using a power plug. Use an approved power plug with earth pin for the connection to the socket.
  2. Power supply connection to a circuit breaker for the permanent connection. Use an approved circuit breaker for the permanent connection. It must be a double pole switch with a minimum 3.5 mm contact gap.
3. Do not release refrigerant during piping work for installation, servicing, reinstallation and during repairing a refrigeration parts. Take care of the liquid refrigerant, it may cause frostbite.
4. Installation work. It may need two people to carry out the installation work.
5. Do not install this appliance in a laundry room or other location where water may drip from the ceiling, etc.

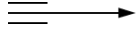

## 2 Specification

### 2.1. CS-E9EKEB CU-E9EKEB

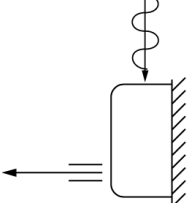
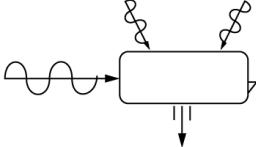
		Unit	CS-E9EKEB	CU-E9EKEB
Performance Test Condition			EUROVENT	
Cooling Capacity		kW kcal/h	2.60 (0.60 - 3.00) 2,240 (520 - 2,580)	
Heating Capacity		kW kcal/h	3.60 (0.60 - 5.40) 3,100 (520 - 4,640)	
Moisture Removal		l/h Pint/h	1.6 3.4	
Power Source (Phase, Voltage, Cycle)		∅ V Hz	Single 230 50	
Airflow Method		<p>OUTLET</p>  <p>INTAKE</p> 	<p>SIDE VIEW</p> 	<p>TOP VIEW</p> 
Air Volume	Lo	m <sup>3</sup> /min (cfm)	Cooling; 6.2 (220) Heating; 6.6 (230)	—
	Me	m <sup>3</sup> /min (cfm)	Cooling; 7.9 (280) Heating; 8.6 (300)	—
	Hi	m <sup>3</sup> /min (cfm)	Cooling; 9.6 (340) Heating; 10.5 (370)	Cooling; 29.8 (1,050)
	SHi	m <sup>3</sup> /min (cfm)	Cooling; 9.9 (350) Heating; 10.8 (380)	—
Noise Level		dB (A)	Cooling; High 39, Low 26 Heating; High 40, Low 27	Cooling; 46 Heating; 47
		Power level dB	Cooling; High 50 Heating; High 51	Cooling; High 59 Heating; High 60
Electrical Data	Input	W	Cooling; 590 (120 - 750) Heating; 845 (115 - 1,360)	
	Running Current	A	Cooling; 2.9 Heating; 4.0	
	EER	W/W (kcal/hw)	Cooling; 4.41 (3.80)	
	COP	W/W (kcal/hw)	Heating; 4.26 (3.67)	
	Starting Current	A	4.0	
Piping Connection Port (Flare piping)		inch inch	G ; Half Union 3/8" L ; Half Union 1/4"	G ; 3-way valve 3/8" L ; 2-way valve 1/4"
Pipe Size (Flare piping)		inch inch	G (gas side) ; 3/8" L (liquid side) ; 1/4"	G (gas side) ; 3/8" L (liquid side) ; 1/4"
Drain Hose	Inner diameter	mm	16	
	Length	m	0.65	

		Unit	CS-E9EKEB	CU-E9EKEB	
Power Cord Length		m	1.8	—	
Number of core-wire			(1.5mm <sup>2</sup> )	—	
Dimensions	Height	inch (mm)	11 - 1/32 (280)	21 - 1/4 (540)	
	Width	inch (mm)	31 - 15/32 (799)	30 - 23/32 (780)	
	Depth	inch (mm)	7 - 7/32 (183)	11 - 3/8 (289)	
Net Weight		lb (kg)	20 (9.0)	77 (35)	
Compressor	Type		—	Hermetic Motor	
	Motor Type		—	Brushless (4-pole)	
	Rated Output	W	—	750	
Fan Motor	Type		Cross-flow Fan	Propeller Fan	
	Material		ASG20k1	P.P	
	Motor Type		Transistor (8-poles)	Induction (8-poles)	
	Input	W	44.3	61.3	
	Rate Output	W	30	40	
	Fan Speed	Lo (Cool/Heat)	rpm	820/880	—
		Me (Cool/Heat)	rpm	1,050/1,140	—
		Hi (Cool/Heat)	rpm	1,280/1,400	800/790
SHi (Cool/Heat)		rpm	1,320/1,440	—	
Heat Exchanger	Description		Evaporator	Condenser	
	Tube material		Copper	Copper	
	Fin material		Aluminium (Pre Coat)	Aluminium	
	Fin Type		Slit Fin	Corrugated Fin	
	Row / Stage		(Plate fin configuration, forced draft) 2 / 15	2 / 24	
	FPI		21	17	
	Size (W x H x L)	mm	610 x 315 x 25.4	718.4 x 504 x 36.4 689.8	
Refrigerant Control Device			—	Capillary Tube	
Refrigeration Oil		(cm <sup>3</sup> )	—	RB68A (400)	
Refrigerant (R410A)		g (oz)	—	930 (32.8)	
Thermostat			Electronic Control	—	
Protection Device			—	Electronic Control	
Air Filter	Material Style		P.P. Honeycomb	—	

- Specifications are subjected to change without prior notice for further improvement.

## 2.2. CS-E12EKEB CU-E12EKEB

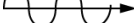
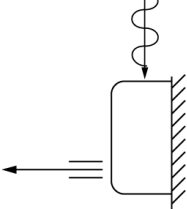
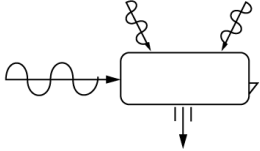
		Unit	CS-E12EKEB	CU-E12EKEB
Performance Test Condition			EUROVENT	
Cooling Capacity		kW kcal/h	3.50 (0.60 - 4.00) 3,010 (520 - 3,440)	
Heating Capacity		kW kcal/h	4.80 (0.60 - 6.60) 4,130 (520 - 5,680)	
Moisture Removal		l/h Pint/h	2.0 4.2	
Power Source (Phase, Voltage, Cycle)		∅ V Hz	Single 230 50	
Airflow Method		<p>OUTLET</p>  <p>INTAKE</p> 	<p>SIDE VIEW</p> 	<p>TOP VIEW</p> 
Air Volume	Lo	m <sup>3</sup> /min (cfm)	Cooling; 6.9 (240) Heating; 8.1 (290)	—
	Me	m <sup>3</sup> /min (cfm)	Cooling; 8.8 (310) Heating; 9.7 (340)	—
	Hi	m <sup>3</sup> /min (cfm)	Cooling; 10.7 (380) Heating; 11.2 (400)	Cooling; 31.0 (1,090)
	SHi	m <sup>3</sup> /min (cfm)	Cooling; 11.0 (390) Heating; 11.6 (410)	—
Noise Level		dB (A)	Cooling; High 42, Low 29 Heating; High 42, Low 33	Cooling; 48 Heating; 50
		Power level dB	Cooling; High 53 Heating; High 53	Cooling; High 61 Heating; High 63
Electrical Data	Input	W	Cooling; 920 (120 - 1,180) Heating; 1,260 (115 - 1,850)	
	Running Current	A	Cooling; 4.3 Heating; 5.8	
	EER	W/W (kcal/hw)	Cooling; 3.80 (3.27)	
	COP	W/W (kcal/hw)	Heating; 3.81 (3.28)	
	Starting Current	A	5.8	
Piping Connection Port (Flare piping)		inch inch	G ; Half Union 1/2" L ; Half Union 1/4"	G ; 3-way valve 1/2" L ; 2-way valve 1/4"
Pipe Size (Flare piping)		inch inch	G (gas side) ; 1/2" L (liquid side) ; 1/4"	G (gas side) ; 1/2" L (liquid side) ; 1/4"
Drain Hose	Inner diameter	mm	16	—
	Length	m	0.65	—
Power Cord Length			1.8	—
Number of core-wire			(1.5mm <sup>2</sup> )	—

		Unit	CS-E12EKEB	CU-E12EKEB	
Dimensions	Height	inch (mm)	11 - 1/32 (280)	21 - 1/4 (540)	
	Width	inch (mm)	31 - 15/32 (799)	30 - 23/32 (780)	
	Depth	inch (mm)	7 - 7/32 (183)	11 - 3/8 (289)	
Net Weight		lb (kg)	20 (9.0)	79 (36)	
Compressor	Type		—	Hermetic Motor	
	Motor Type		—	Brushless (4-pole)	
	Rated Output	W	—	750	
Fan Motor	Type		Cross-flow Fan	Propeller Fan	
	Material		ASG20k1	P.P	
	Motor Type		Transistor (8-poles)	Induction (8-poles)	
	Input	W	44.3	65.9	
	Rate Output	W	30	40	
	Fan Speed	Lo (Cool/Heat)	rpm	910/1,080	—
		Me (Cool/Heat)	rpm	1,165/1,290	—
		Hi (Cool/Heat)	rpm	1,420/1,500	840 / 820
SHi (Cool/Heat)		rpm	1,460/1,540	—	
Heat Exchanger	Description		Evaporator	Condenser	
	Tube material		Copper	Copper	
	Fin material		Aluminium (Pre Coat)	Aluminium	
	Fin Type		Slit Fin	Corrugated Fin	
	Row / Stage		(Plate fin configuration, forced draft)		
	FPI		2 / 15	2 / 24	
	Size (W x H x L)	mm	610 x 315 x 25.4	718.4 x 504 x 36.4 689.8	
Refrigerant Control Device			—	Capillary Tube	
Refrigeration Oil		(cm <sup>3</sup> )	—	RB68A (400)	
Refrigerant (R410A)		g (oz)	—	970 (34.2)	
Thermostat			Electronic Control	—	
Protection Device			—	Electronic Control	
Air Filter	Material		P.P.	—	
	Style		Honeycomb	—	

- Specifications are subjected to change without prior notice for further improvement.

### 3 Features

#### 3.1. Super Air Purifying System with SUPER alleru-buster

##### 3.1.1. Supersonic Air Purifying System

- The Supersonic Air Purifying System incorporated in the indoor unit generates supersonic waves.
- The system works in combination with the filter to collect dust and dirt in the air for faster, more efficient air purification.

■ Changes in dust concentration

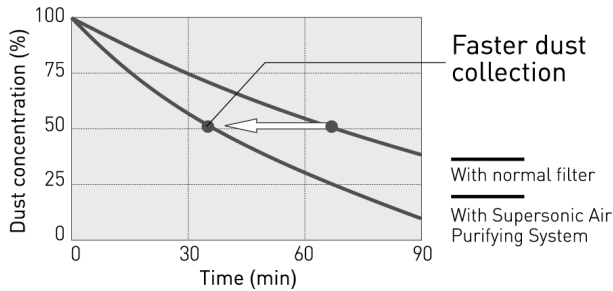

##### 3.1.2. SUPER alleru-buster filter

- The SUPER alleru-buster filter combines three effects in one—anti-allergen, anti-virus, anti-bacteria protection—to keep room air clean and healthful.

Anti-allergen protection	Inactivates more than <b>99%</b> of all filter-captured allergens
Anti-virus protection	Inactivates more than <b>99%</b> of all filter-captured viruses
Anti-bacteria/Anti-mould protection	Enzymatic action eliminates more than <b>99%</b> of all filter-captured bacteria

Here, inactivate means to suppress normal activity. This inactivation of mite allergens has been verified by the University of Edinburgh in the UK.

#### 3.2. Ion Freshener

- Around 20,000 negative ions/cc are generated to freshen the room. It's like being next to a waterfall or in a forest.

#### 3.3. Super Quiet

- The indoor unit operates at a whisper-quiet 26dB. You can also press the Quiet Mode button to lower the operating noise 3 dB. We've reduced the noise of the outdoor unit, too, with the e-scroll Compressor and 2-Wing Fan. You can run the air conditioner at night and enjoy a deeper, more comfortable sleep, and without bothering your neighbours.



#### 3.4. Powerful Heating And Top-class Energy Efficiency

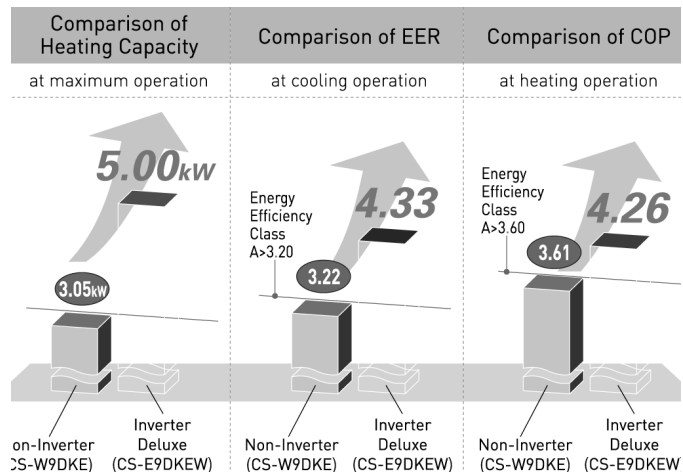

## 4 Location of controls and components

### 4.1. Indoor Unit

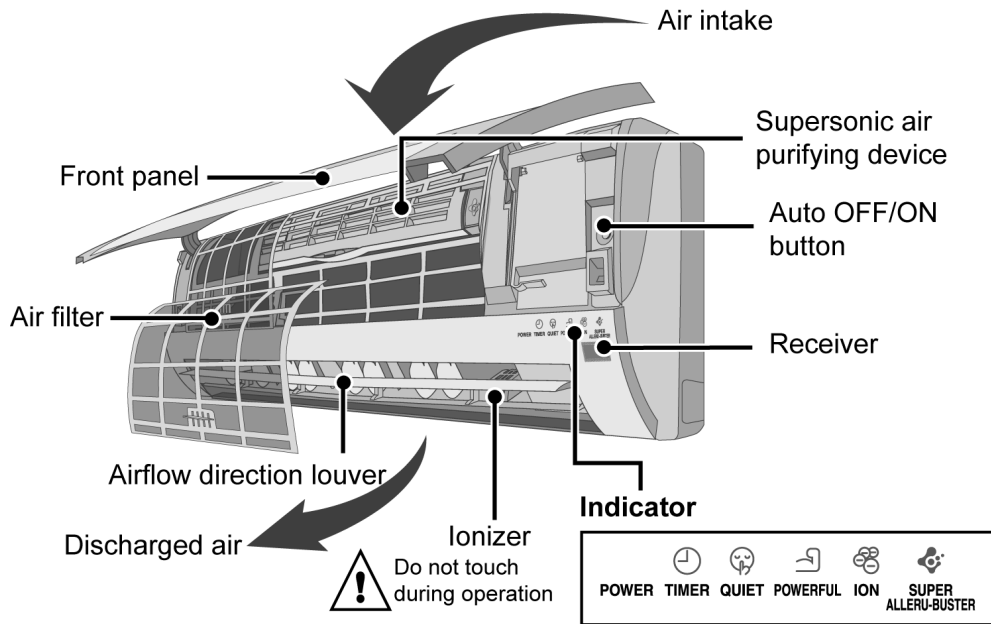

### 4.2. Outdoor Unit

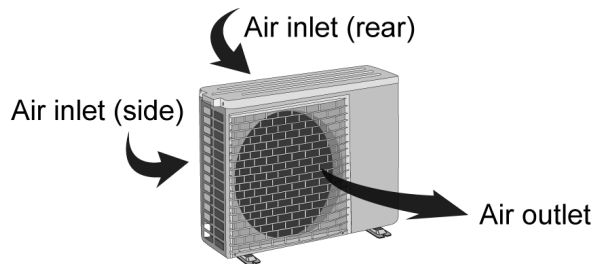

### 4.3. Remote Control

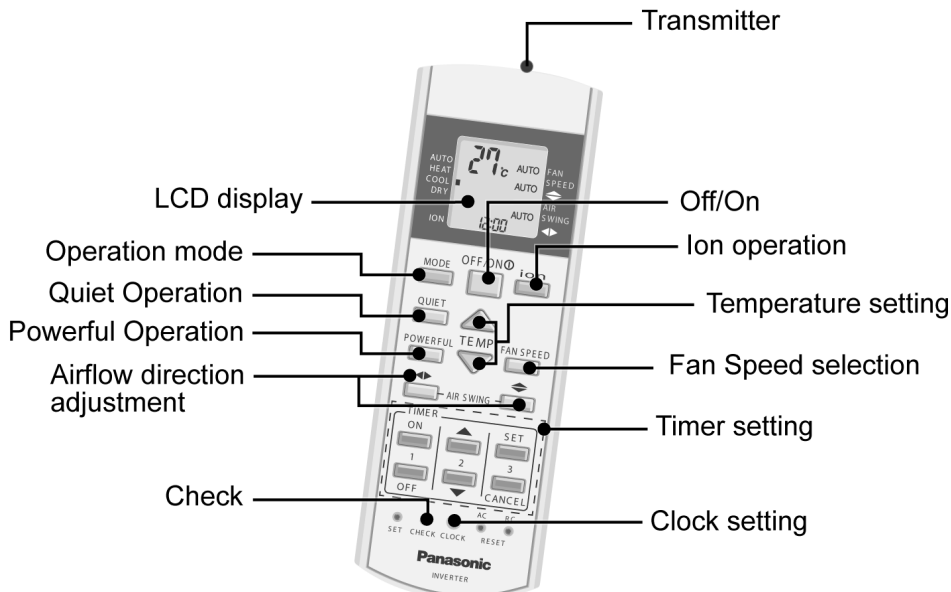

# 5 Dimension

## 5.1. Indoor Unit & Remote Control

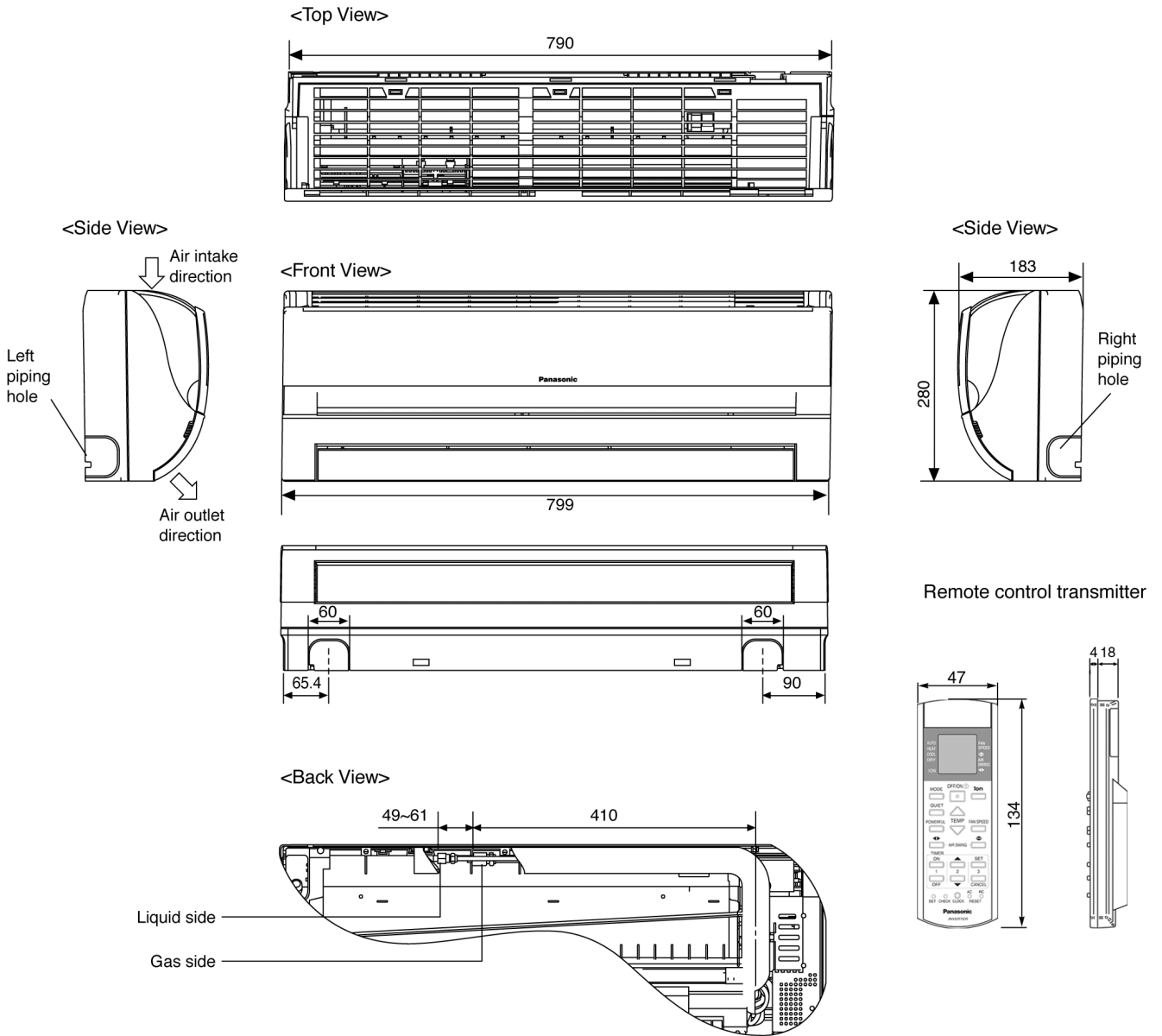

Relative position between the indoor unit and the installation plate <Front View>

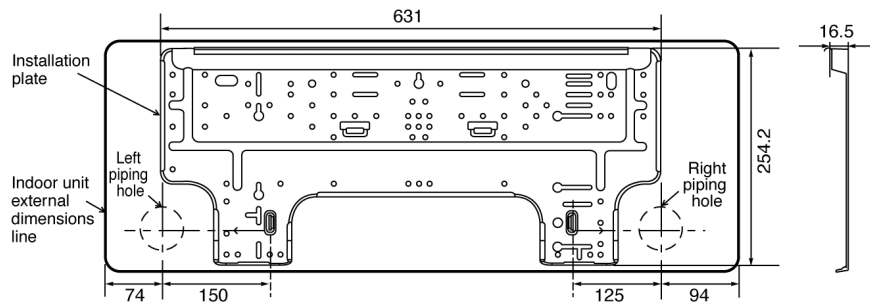

Unit : mm

## 5.2. Outdoor Unit

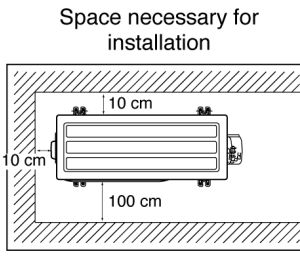

Anchor Bolt Pitch  
320 x 570

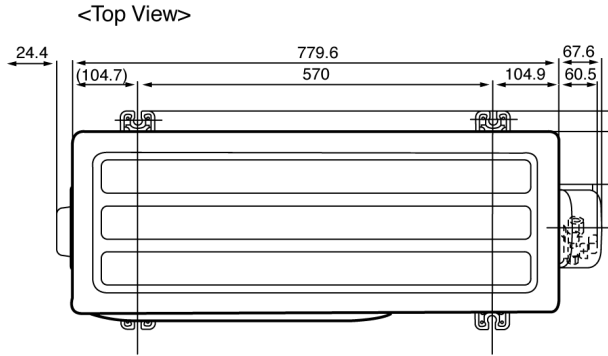

2-way valve at Liquid side  
(High Pressure)

3-way valve at Gas side  
(Low Pressure)

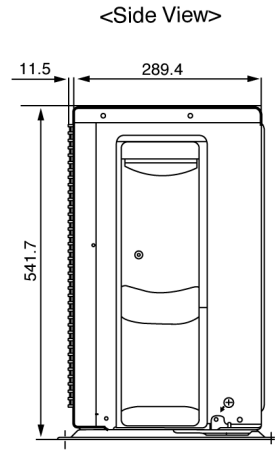
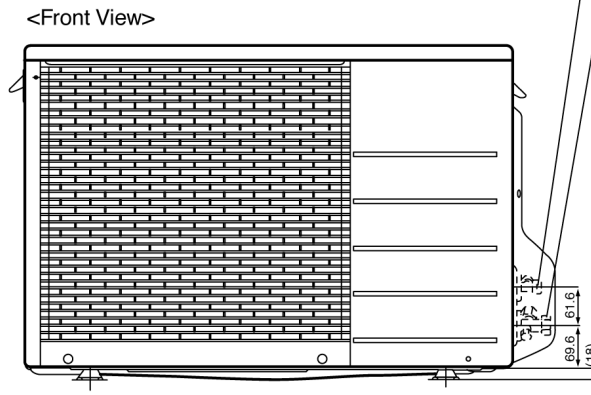
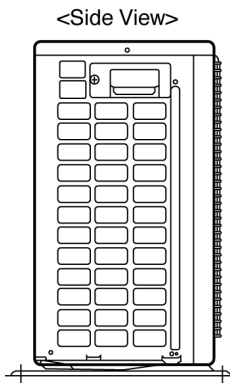

Unit: mm



# 6 Refrigeration Cycle Diagram

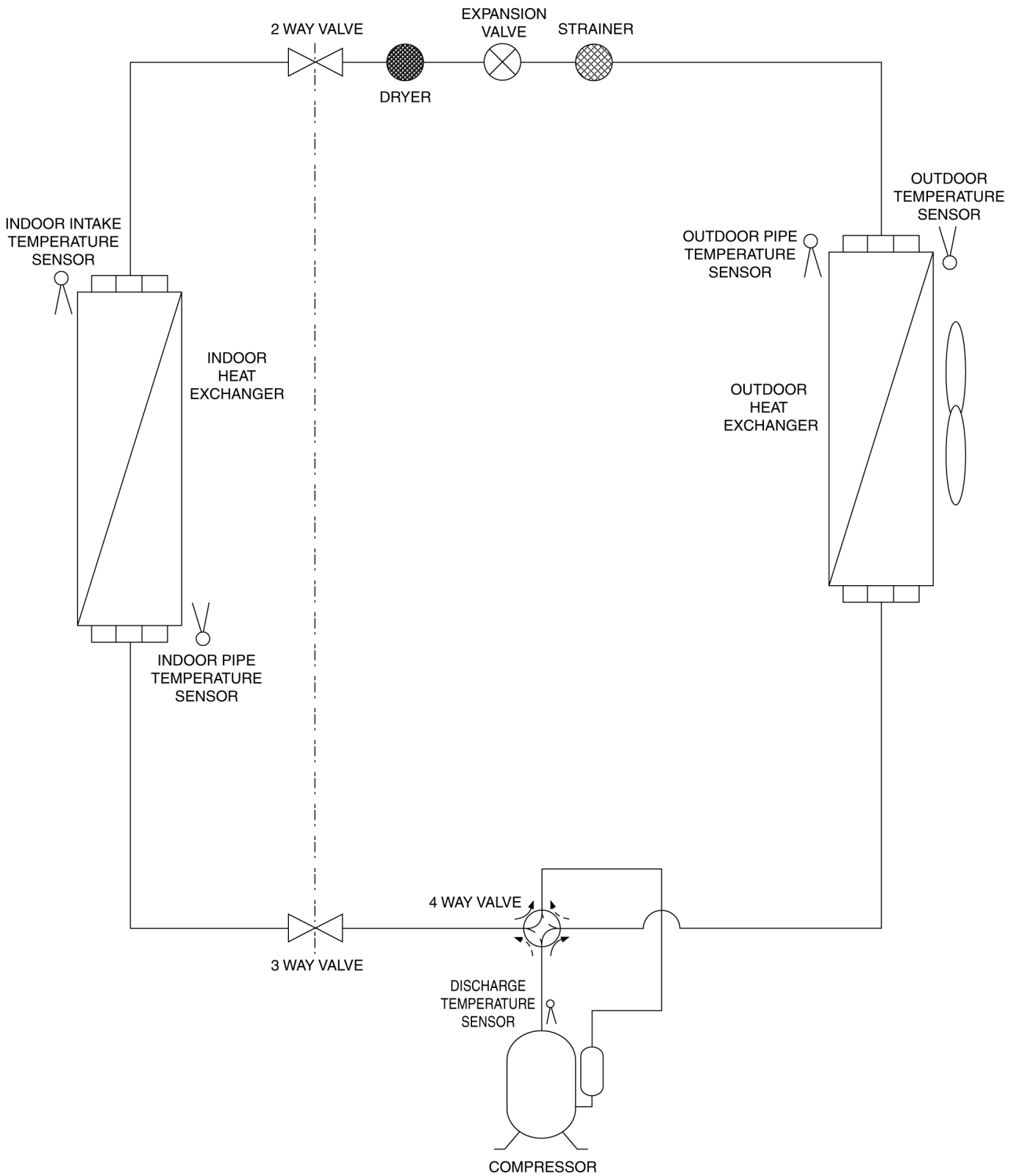

# 7 Block Diagram

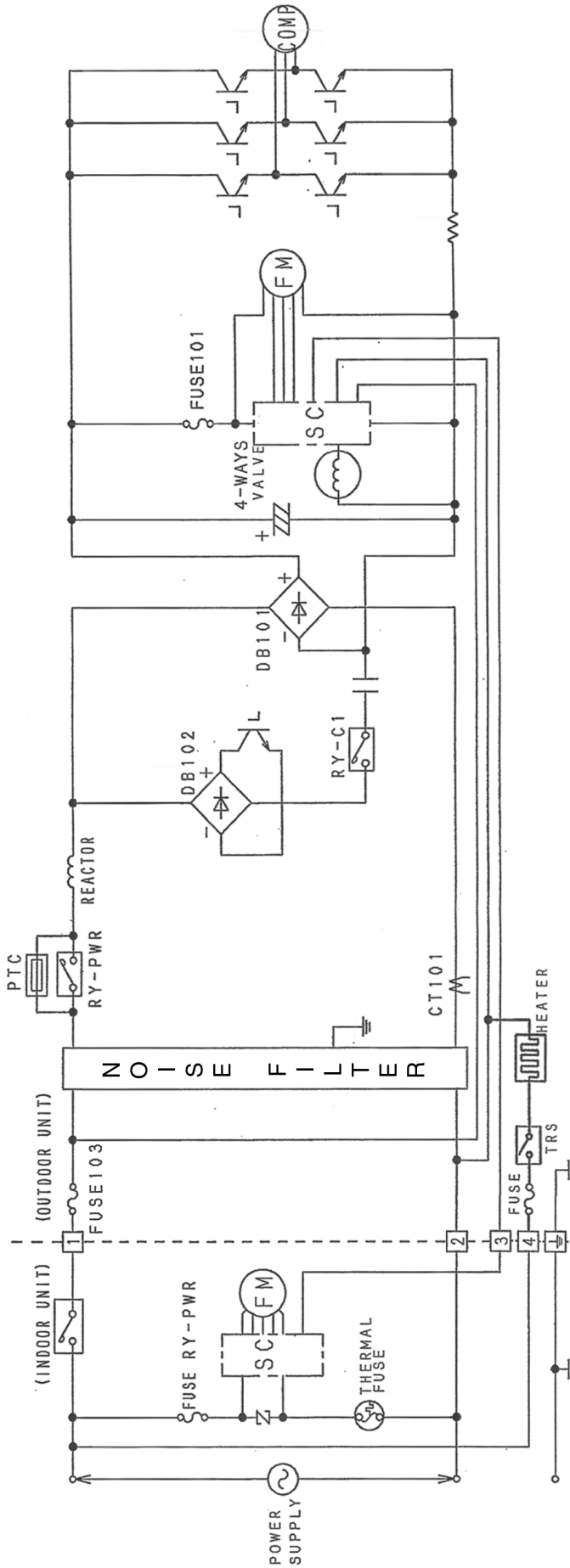

# 8 Wiring Diagram

## 8.1. CS-C9EKEB CS-C12EKEB

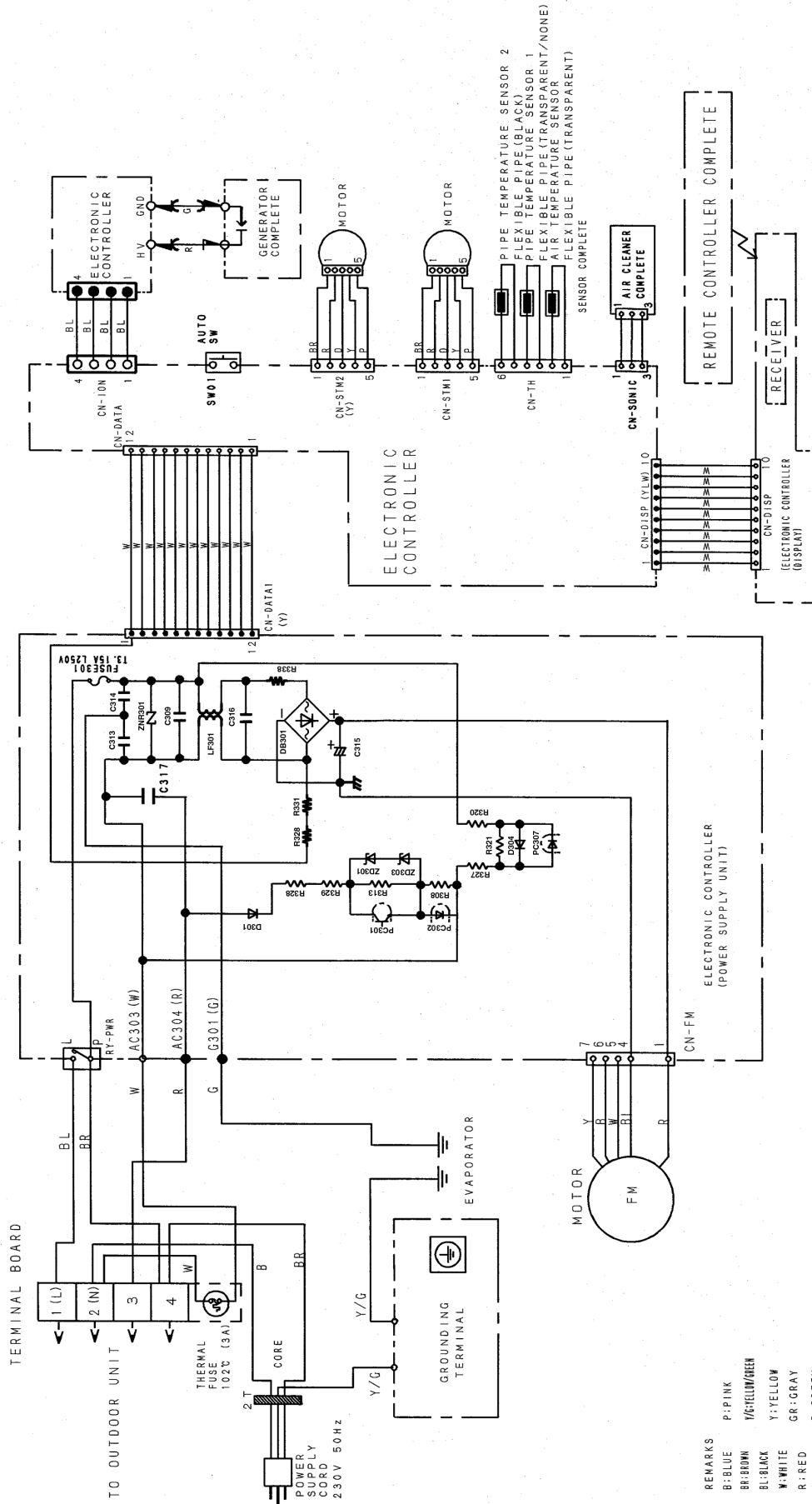

## 8.2. CU-C9EKEB CU-C12EKEB

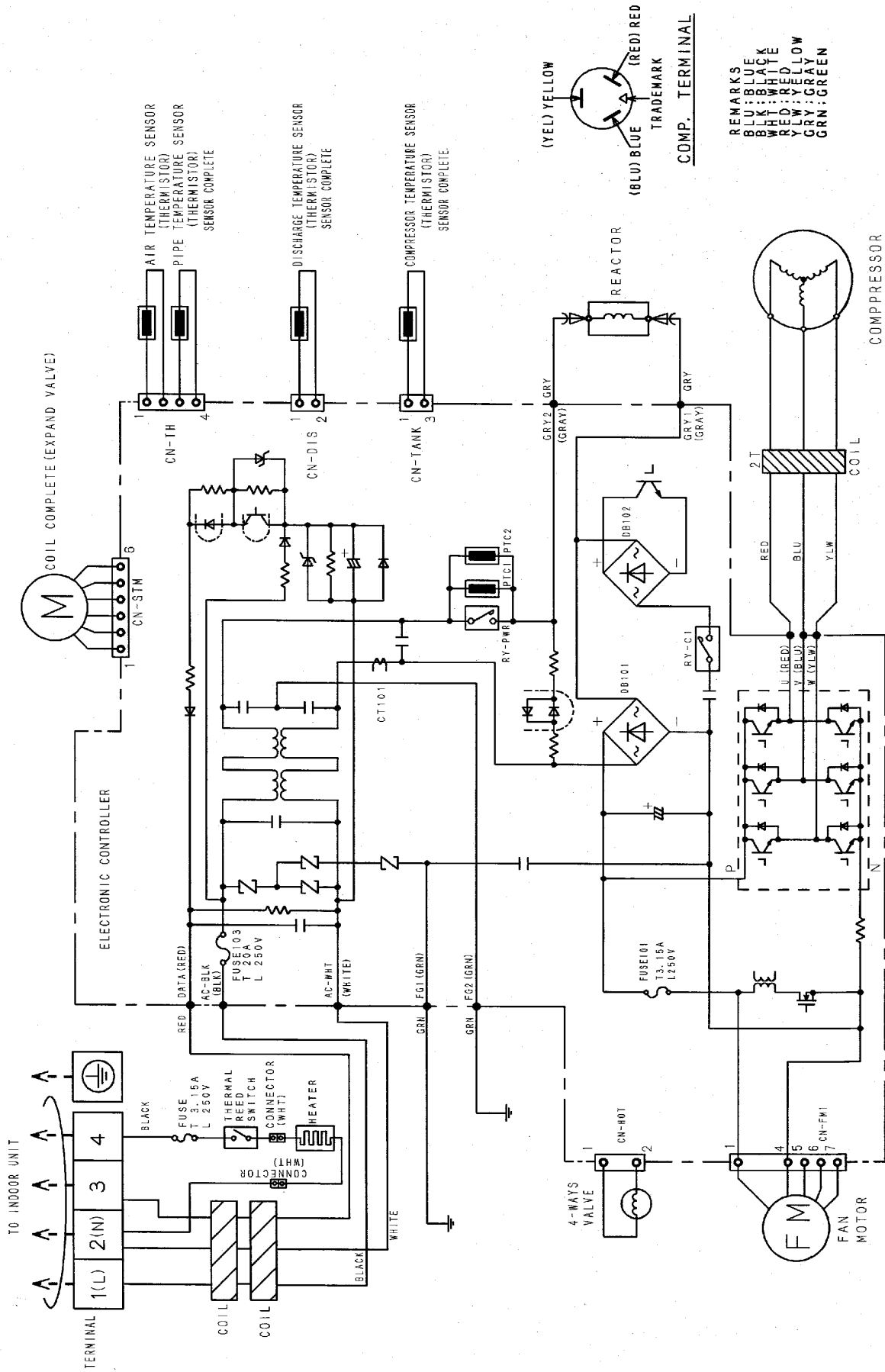

# 9 Printed Circuit Board

## 9.1. Indoor Unit

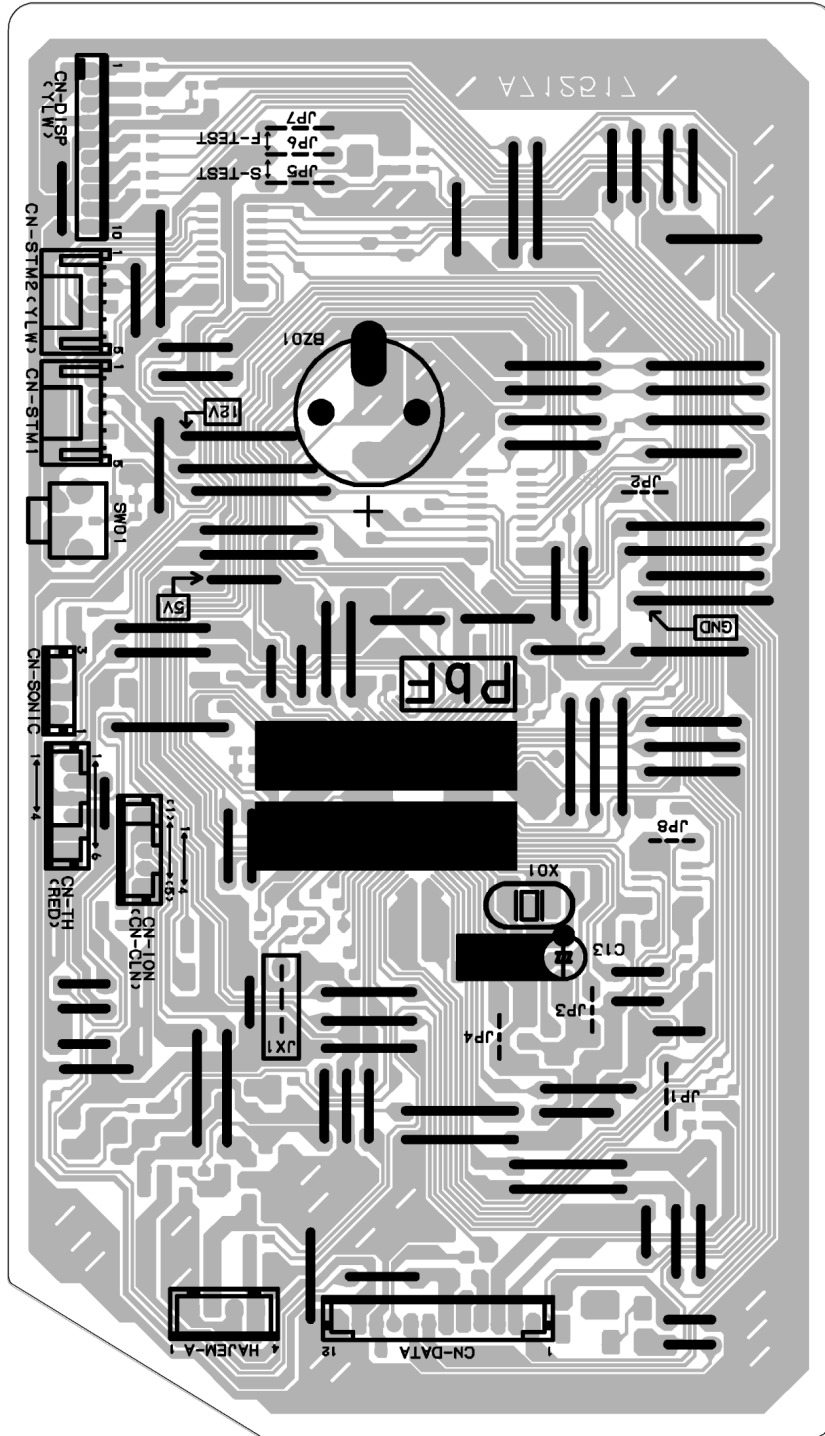

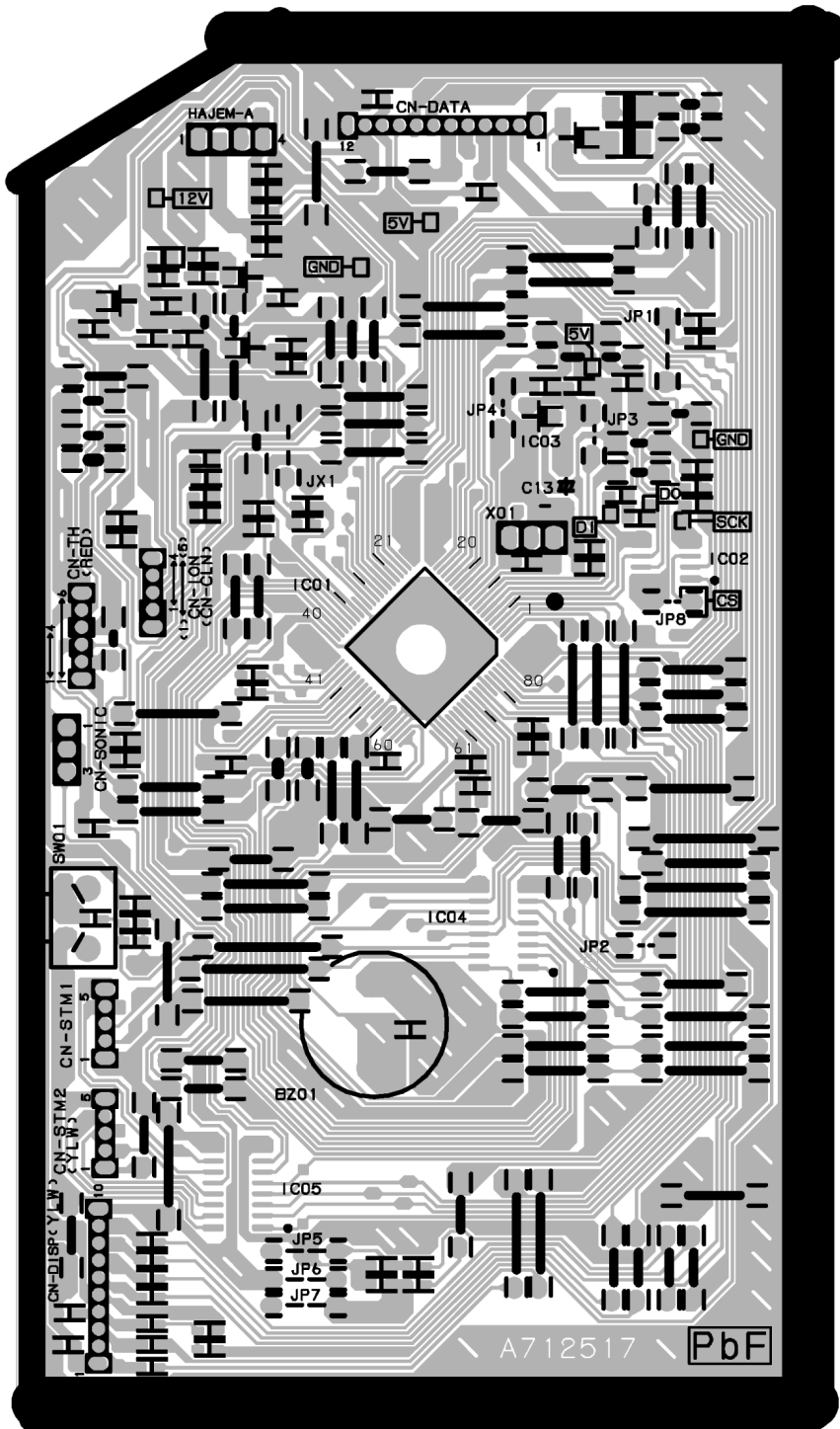

## 9.2. Outdoor Unit

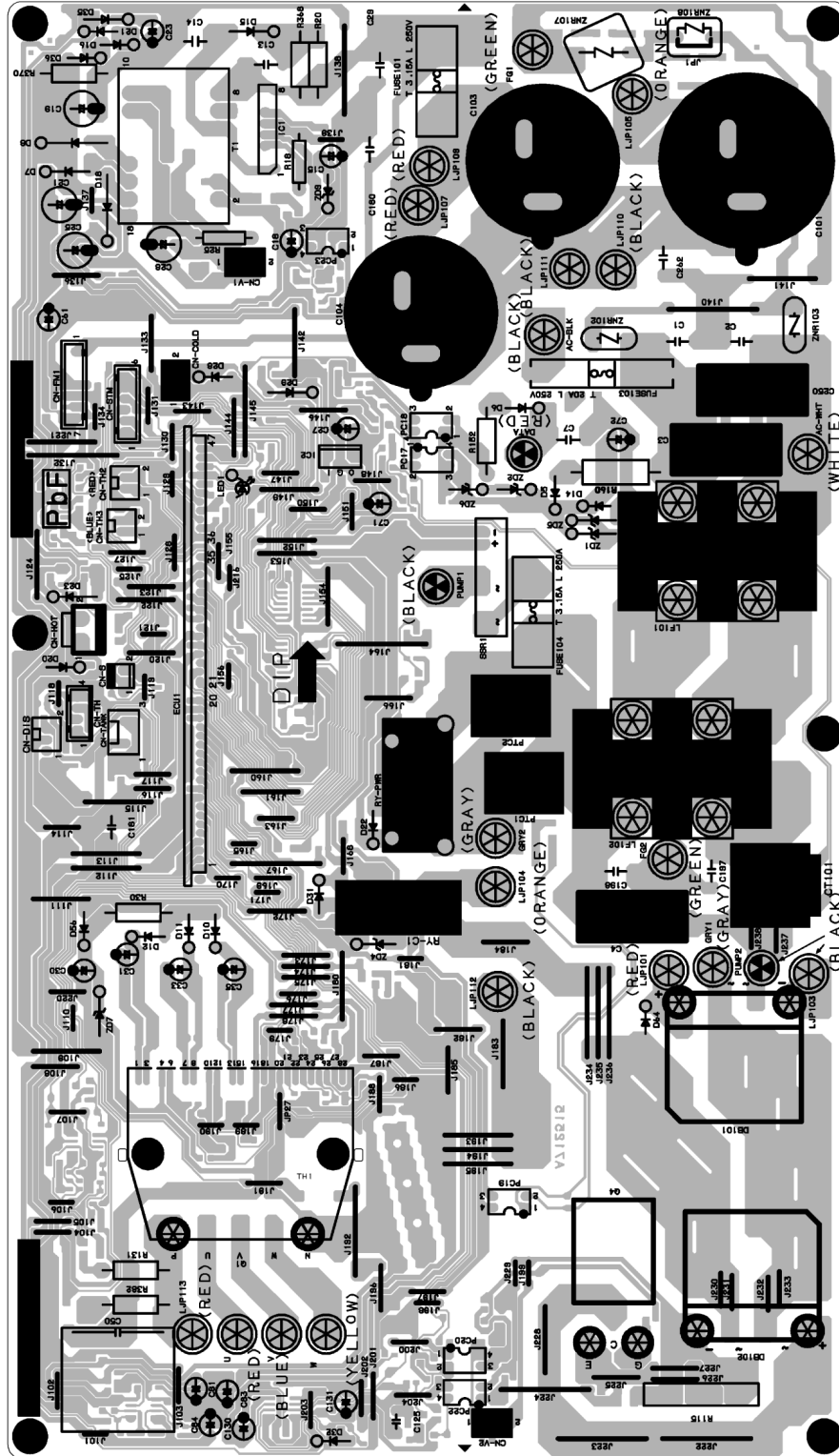





# 10 Simplified Electronic Circuit Diagram

## 10.1. Indoor Unit

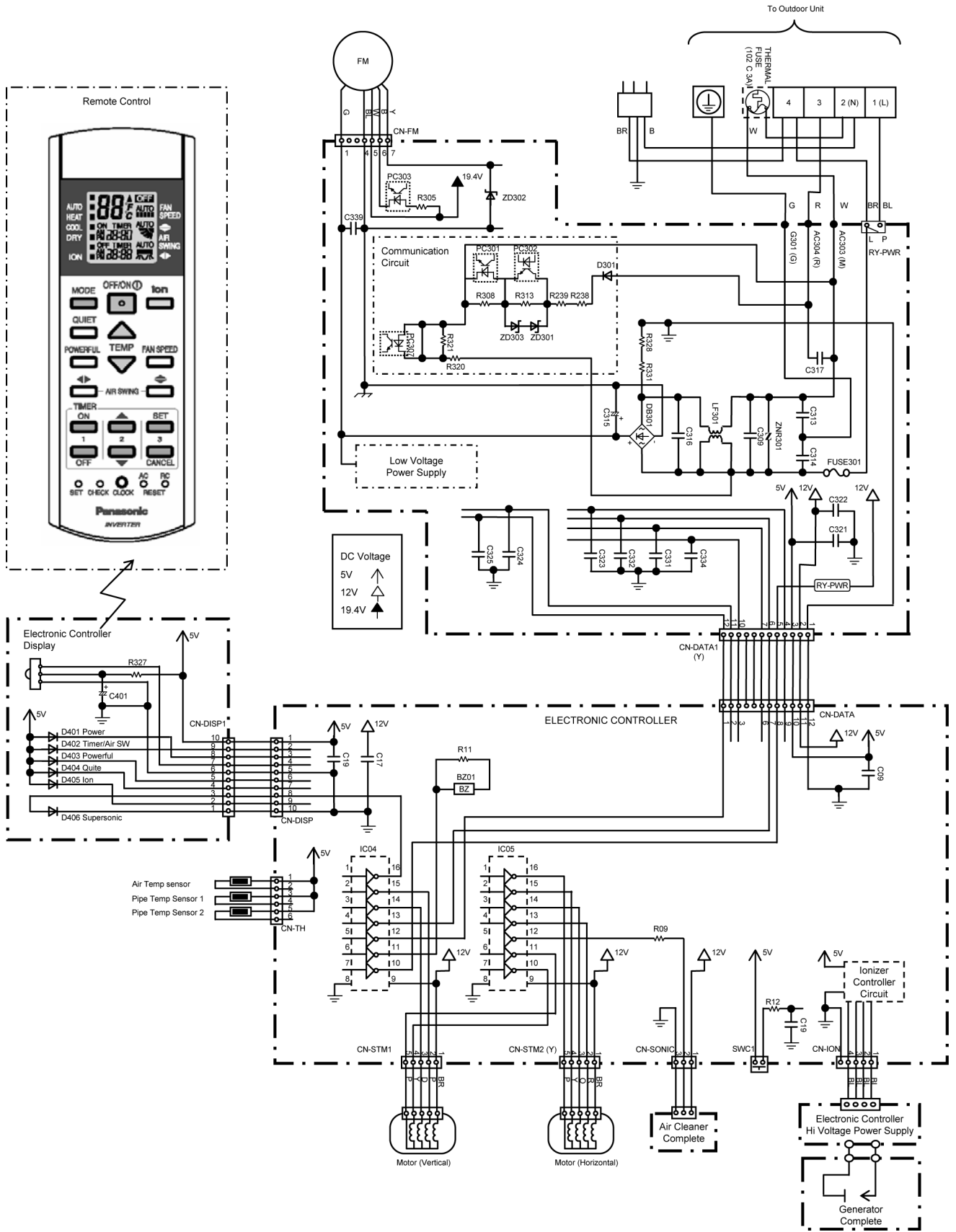

## 10.2. Outdoor Unit

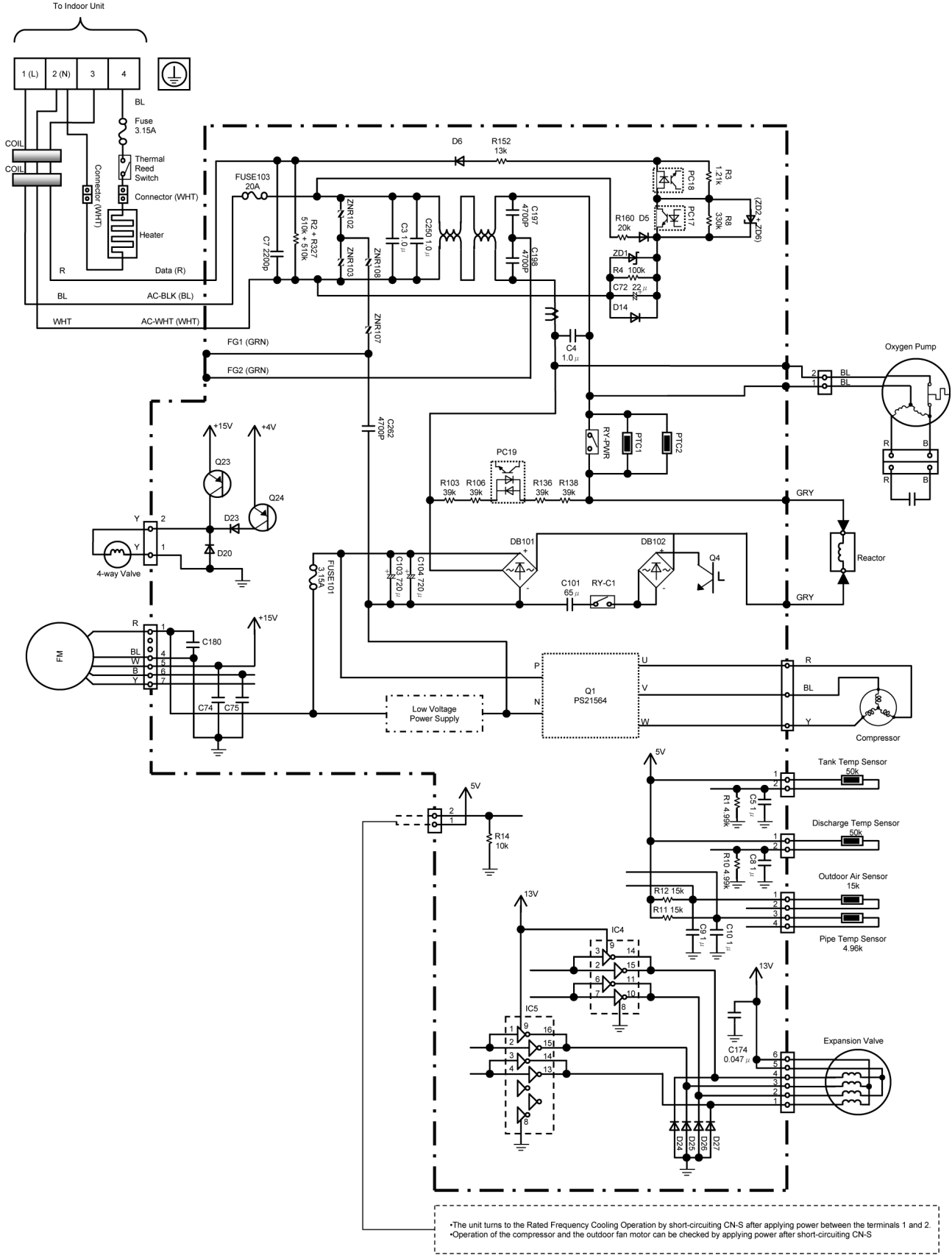

# 11 Installation Instructions

## 11.1. Select The Best Location

### INDOOR UNIT

- There should not be any heat source or steam near the unit.
- There should not be any obstacles blocking the air circulation.
- A place where air circulation in the room is good.
- A place where drainage can be easily done.
- A place where noise prevention is taken into consideration.
- Do not install the unit near the door way.
- Ensure the spaces indicated by arrows from the wall, ceiling, fence or other obstacles.
- Recommended installation height for indoor unit shall be at least 2.5 m.

### OUTDOOR UNIT

- If an awning is built over the unit to prevent direct sunlight or rain, be careful that heat radiation from the condenser is not obstructed.
- There should not be any animal or plant which could be affected by hot air discharged.
- Keep the spaces indicated by arrows from wall, ceiling, fence or other obstacles.
- Do not place any obstacles which may cause a short circuit of the discharged air.
- If piping length is over the rated length, additional refrigerant should be added as shown in the table.

Model	Piping size		Rated Length (m)	Max. Elevation (m)	Max. Piping Length (m)	Additional Refrigerant (g/m)
	Gas	Liquid				
E9EK	3/8"	1/4"	7.5	5	15	20
E12EK	1/2"	1/4"	7.5	5	15	20

### Indoor/Outdoor Unit Installation Diagram

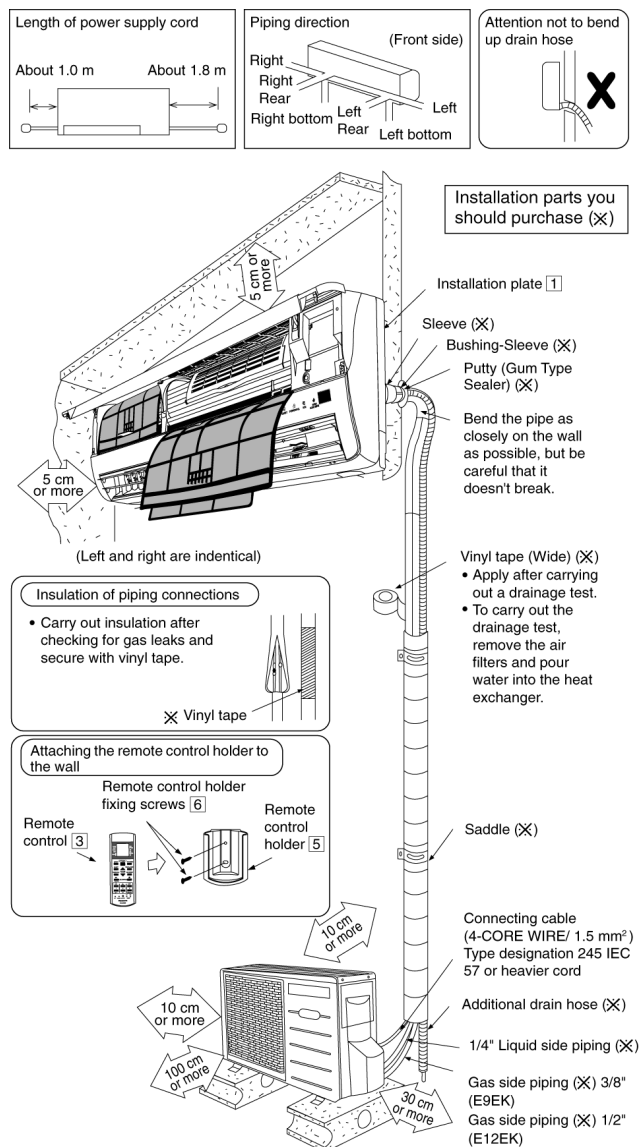

- This illustration is for explanation purposes only. The indoor unit will actually face a different way.

## 11.2. Indoor Unit

### 11.2.1. HOW TO FIX INSTALLATION PLATE

The mounting wall is strong and solid enough to prevent it from the vibration.

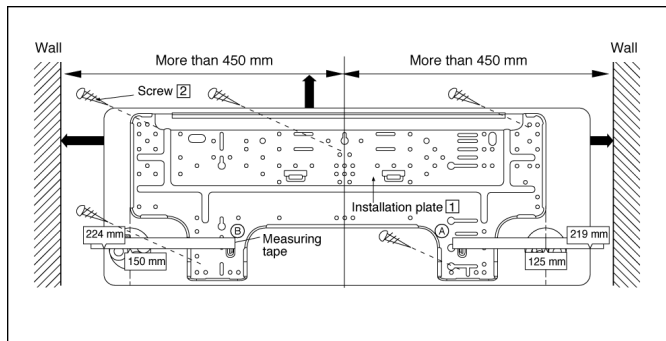

The centre of installation plate should be at more than 450 mm at right and left of the wall.

The distance from installation plate edge to ceiling should more than 67 mm.

From installation plate left edge to unit's left side is 74 mm.

From installation plate right edge to unit's right is 94 mm.

- Ⓑ :
- For left side piping, piping connection for liquid should be about 15 mm from this line.
  - For left side piping, piping connection for gas should be about 45 mm from this line.
  - For left side piping, piping connection cable should be about 800 mm from this line.

1. Mount the installation plate on the wall with 5 screws or more.

(If mounting the unit on the concrete wall consider using anchor bolts.)

- Always mount the installation plate horizontally by aligning the marking-off line with the thread and using a level gauge.

2. Drill the piping plate hole with  $\varnothing 70$  mm hole-core drill.

- Line according to the left and right side of the installation plate. The meeting point of the extended line is the centre of the hole. Another method is by putting measuring tape at position as shown in the diagram above. The hole centre is obtained by measuring the distance namely 150 mm and 125 mm for left and right hole respectively.
- Drill the piping hole at either the right or the left and the hole should be slightly slanted to the outdoor side.

### 11.2.2. TO DRILL A HOLE IN THE WALL AND INSTALL A SLEEVE OF PIPING

1. Insert the piping sleeve to the hole.
2. Fix the bushing to the sleeve.
3. Cut the sleeve until it extrudes about 15 mm from the wall.

#### Caution

When the wall is hollow, please be sure to use the sleeve for tube ass'y to prevent dangers caused by mice biting the connecting cable.

4. Finish by sealing the sleeve with putty or caulking compound at the final stage.

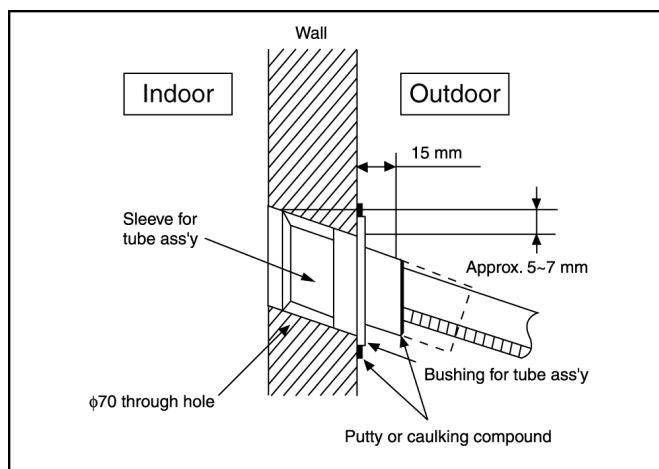

### 11.2.3. INDOOR UNIT INSTALLATION

#### 1. For the right rear piping

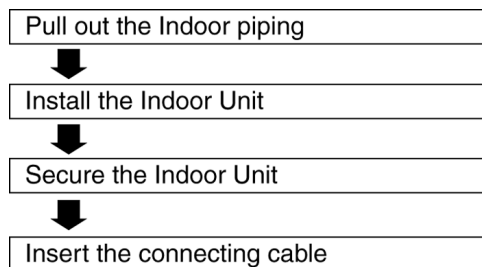

#### 2. For the right and right bottom piping

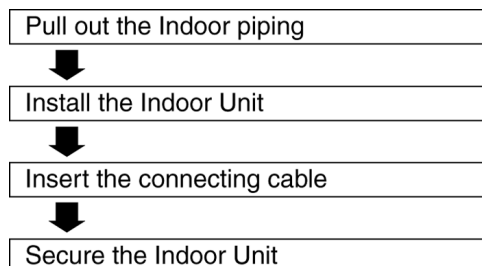

### 3. For the embedded piping

- Replace the drain hose
- ↓
- Bend the embedded piping
  - Use a spring bender or equivalent to bend the piping so that the piping is not crushed.
- ↓
- Install the Indoor Unit
- ↓
- Cut and flare the embedded piping
  - When determining the dimensions of the piping, slide the unit all the way to the left on the installation plate.
  - Refer to the section "Cutting and flaring the piping".
- ↓
- Pull the connecting cable into Indoor Unit
  - The inside and outside connecting cable can be connected without removing the front grille.
- ↓
- Connect the piping
  - Please refer to "Connecting the piping" column in outdoor unit section. (Below steps are done after connecting the outdoor piping and gas-leakage confirmation.)
- ↓
- Insulate and finish the piping
  - Please refer to "Piping and finishing" column of outdoor section and "Insulation of piping connections" column as mentioned in Indoor/Outdoor Unit Installation.
- ↓
- Secure the Indoor Unit

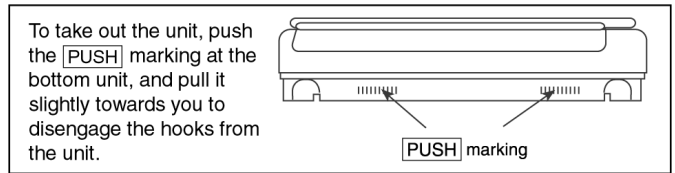
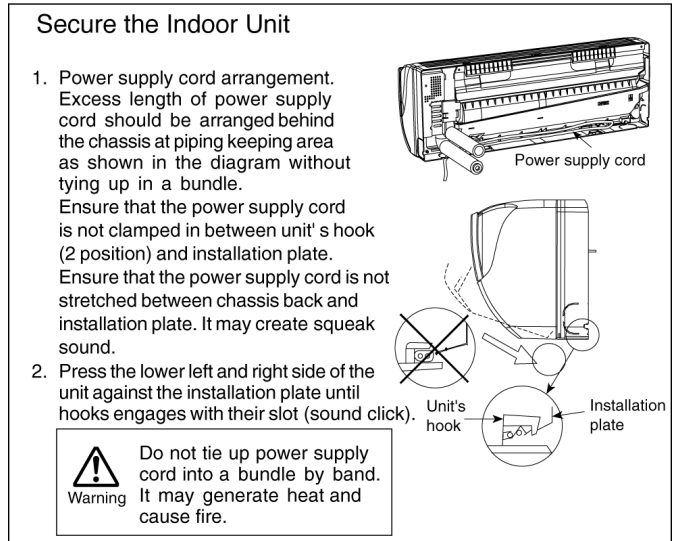
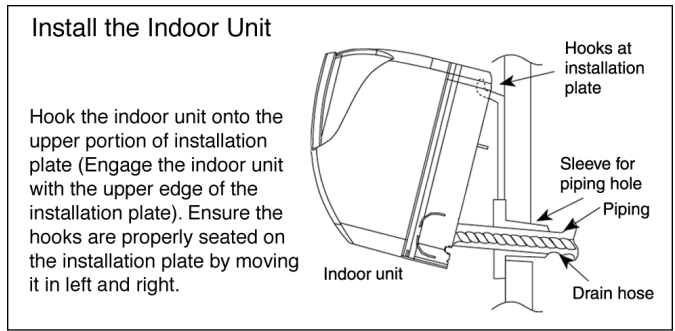
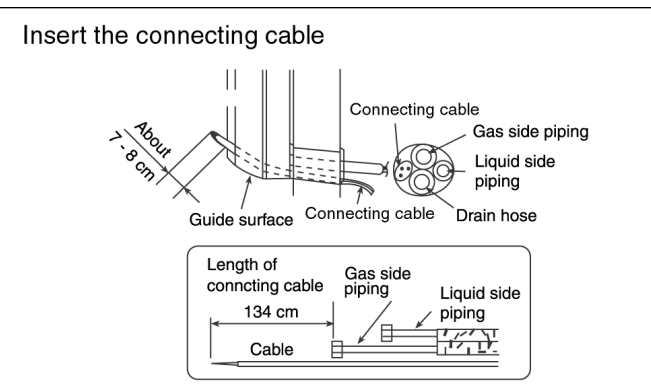
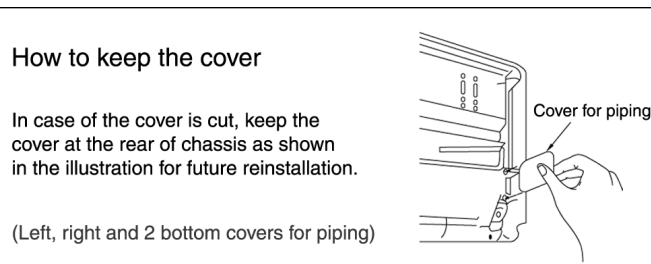
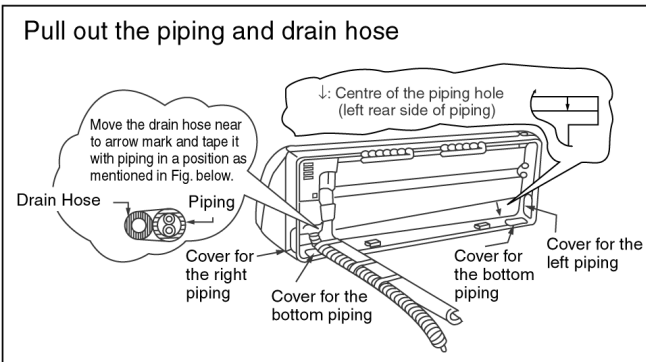

(This can be used for left rear piping & left bottom piping also.)

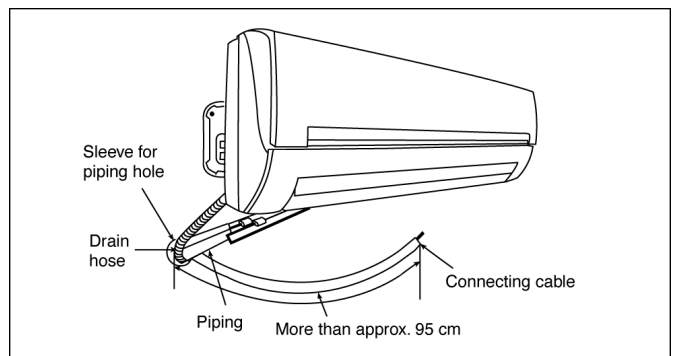
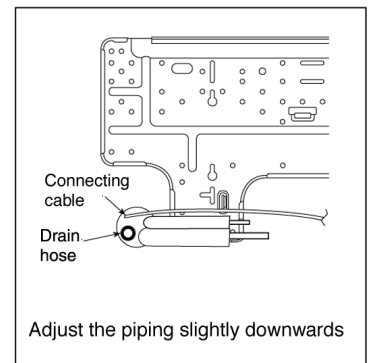
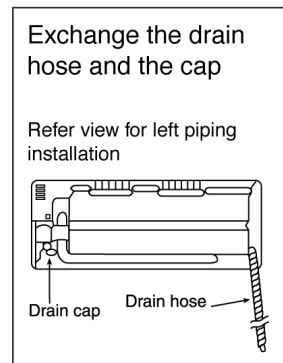

- How to pull the piping and drain hose out, in case of the embedded piping.

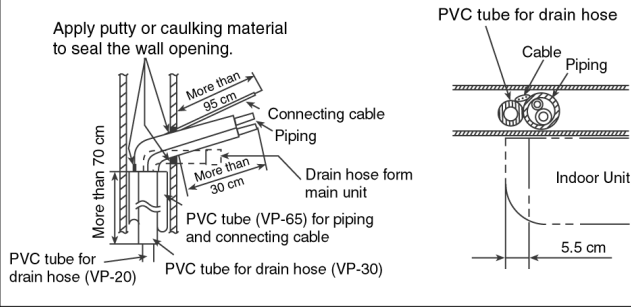

- In case of left piping how to insert the connecting cable and drain hose.

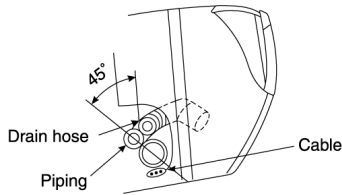

(For the right piping, follow the same procedure)

## 11.2.4. CONNECT THE CABLE TO THE INDOOR UNIT

1. The inside and outside connecting cable can be connected without removing the front grille.
2. Connecting cable between indoor unit and outdoor unit shall be approved polychloroprene sheathed  $4 \times 1.5 \text{ mm}^2$  flexible cord, type designation 245 IEC 57 or heavier cord.
  - Ensure the color of wires of outdoor unit and the terminal Nos. are the same to the indoor's respectively.
  - Earth lead wire shall be longer than the other lead wires as shown in the figure for the electrical safety in case of the slipping out of the cord from the anchorage.

Terminals on the indoor unit	1	2	3	4	
Colour of wires					
Terminals on the outdoor unit	1	2	3	4	

- Secure the cable onto the control board with the holder (clamper).

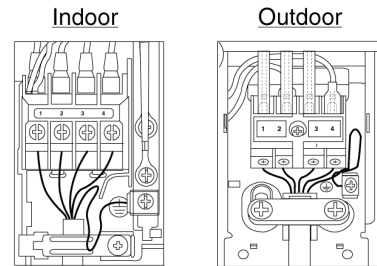

## 11.2.5. INSTALLATION OF SUPER ALLERU-BUSTER FILTER

1. Open the front panel.
2. Remove the air filter.
3. Remove Supersonic air purifying device.
4. Open the Supersonic air purifying device frame.
5. Insert the super alleru-buster filter and close the Supersonic air purifying device frame as show in illustration at right.

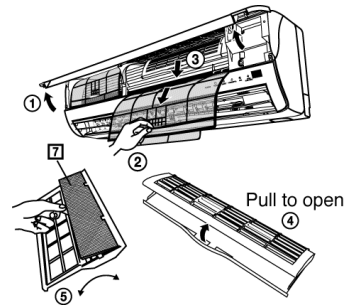

## 11.2.6. HOW TO TAKE OUT FRONT GRILLE

Please follow the steps below to take out front grille if necessary such as when servicing.

1. Set the vertical airflow direction louvers to the horizontal position.
2. Slide down the 2 caps on the front grille as shown in the illustration below, and then remove the 2 mounting screws.
3. Pull the lower section of the front grille towards you to remove the front grille.

When reinstalling the front grille, first set the vertical airflow direction louvers to the horizontal position and then carry out above steps 2 - 3 in the reverse order.

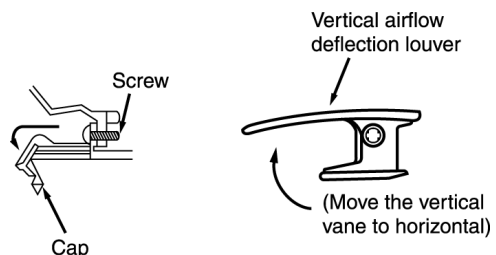

## 11.3. Outdoor Unit

### 11.3.1. INSTALL THE OUTDOOR UNIT

- After selecting the best location, start installation according to Indoor/Outdoor Unit Installation Diagram.
1. Fix the unit on concrete or rigid frame firmly and horizontally by bolt nut ( $\varnothing 10$  mm).
  2. When installing at roof, please consider strong wind and earthquake. Please fasten the installation stand firmly with bolt or nails.

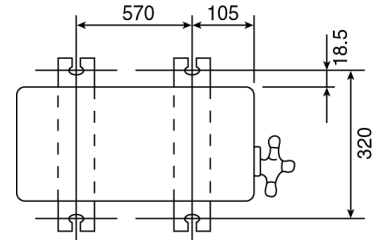

### 11.3.2. CONNECTING THE PIPING

#### Connecting The Piping To Indoor Unit

Please make flare after inserting flare nut (locate at joint portion of tube assembly) onto the copper pipe. (In case of using long piping)

Connect the piping

- Align the center of piping and sufficiently tighten the flare nut with fingers.
- Further tighten the flare nut with torque wrench in specified torque as stated in the table.

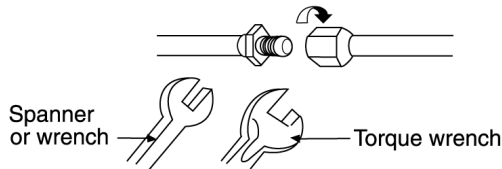

MODEL	Piping size (Torque)	
	Gas	Liquid
E9EK	3/8" (42 N.m)	1/4" (18 N.m)
E12EK	1/2" (55 N.m)	1/4" (18 N.m)

#### Connecting The Piping To Outdoor Unit

Decide piping length and then cut by using pipe cutter. Remove burrs from cut edge. Make flare after inserting the flare nut (located at valve) onto the copper pipe.

Align center of piping to valves and then tighten with torque wrench to the specified torque as stated in the table.

### CUTTING AND FLARING THE PIPING

1. Please cut using pipe cutter and then remove the burrs.
2. Remove the burrs by using reamer. If burrs is not removed, gas leakage may be caused.  
Turn the piping end down to avoid the metal powder entering the pipe.
3. Please make flare after inserting the flare nut onto the copper pipes.

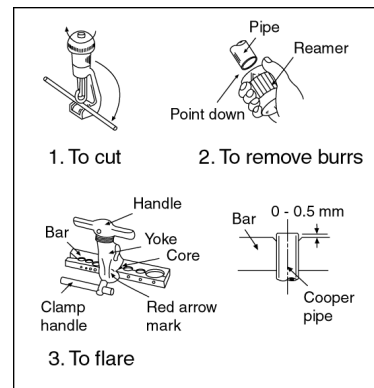

#### ■ Improper flaring ■

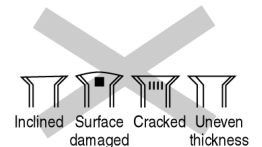

When properly flared, the internal surface of the flare will evenly shine and be of even thickness. Since the flare part comes into contact with the connections, carefully check the flare finish.

### 11.3.3. EVACUATION OF THE EQUIPMENT

WHEN INSTALLING AN AIR CONDITIONER, BE SURE TO EVACUATE THE AIR INSIDE THE INDOOR UNIT AND PIPES in the following procedure.

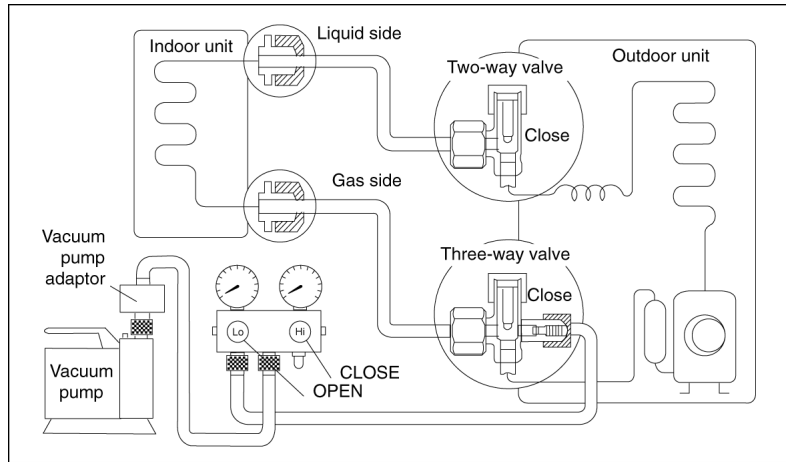

1. Connect a charging hose with a push pin to the Low side of a charging set and the service port of the 3-way valve.
  - Be sure to connect the end of the charging hose with the push pin to the service port.
2. Connect the center hose of the charging set to a vacuum pump with check valve, or vacuum pump and vacuum pump adaptor.
3. Turn on the power switch of the vacuum pump and make sure that the needle in the gauge moves from 0 cmHg (0 MPa) to -76 cmHg (-0.1 MPa). Then evacuate the air approximately ten minutes.
4. Close the Low side valve of the charging set and turn off the vacuum pump. Make sure that the needle in the gauge does not move after approximately five minutes.

Note: BE SURE TO FOLLOW THIS PROCEDURE IN ORDER TO AVOID REFRIGERANT GAS LEAKAGE.

5. Disconnect the charging hose from the vacuum pump and from the service port of the 3-way valve.
6. Tighten the service port caps of the 3-way valve at a torque of 18 N.m with a torque wrench.
7. Remove the valve caps of both of the 2-way valve and 3-way valve. Position both of the valves to "OPEN" using a hexagonal wrench (4 mm).
8. Mount valve caps onto the 2-way valve and the 3-way valve.
  - Be sure to check for gas leakage.







#### CAUTION

- If gauge needle does not move from 0 cmHg (0 MPa) to -76 cmHg (-0.1 MPa), in step ③ above take the following measure:
- If the leak stops when the piping connections are tightened further, continue working from step ③.
- If the leak does not stop when the connections are retightened, repair the location of leak.
- Do not release refrigerant during piping work for installation and reinstallation. Take care of the liquid refrigerant, it may cause frostbite.

### 11.3.4. CONNECT THE CABLE TO THE OUTDOOR UNIT

(FOR DETAIL REFER TO WIRING DIAGRAM AT UNIT)

1. Remove the control board cover from the unit by loosening the screw.
2. Connecting cable between indoor unit and outdoor unit shall be approved polychloroprene sheathed 4 × 1.5 mm<sup>2</sup> flexible cord, type designation 245 IEC 57 or heavier cord.

Terminals on the indoor unit	1	2	3	4	
Colour of wires					
Terminals on the outdoor unit	1	2	3	4	

3. Secure the cable onto the control board with the holder (clammer).
4. Attach the control board cover back to the original position with the screw.



### 11.3.5. PIPE INSULATION

1. Please carry out insulation at pipe connection portion as mentioned in Indoor/Outdoor Unit Installation Diagram. Please wrap the insulated piping end to prevent water from going inside the piping.
2. If drain hose or connecting piping is in the room (where dew may form), please increase the insulation by using POLY-E FOAM with thickness 6 mm or above.

### 11.3.6. OUTDOOR UNIT DRAIN WATER

- Water will drip from the basepan hole area during defrost function.

To avoid water dripping, do not stand or place objects at this area.

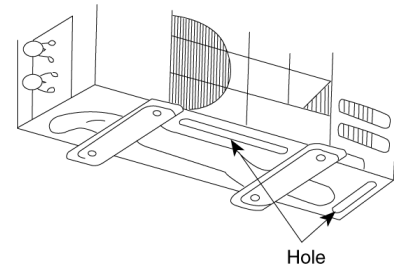

### 11.3.7. CHECK THE DRAINAGE

- Open front panel and remove air filters.  
(Drainage checking can be carried out without removing the front grille.)
- Pour a glass of water into the drain tray-styrofoam.
- Ensure that water flows out from drain hose of the indoor unit.

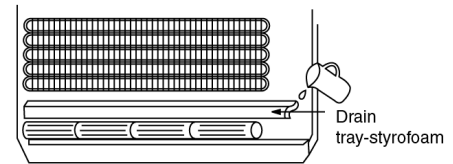

### 11.3.8. EVALUATION OF THE PERFORMANCE

- Operate the unit at cooling operation mode for fifteen minutes or more.
- Measure the temperature of the intake and discharge air.
- Ensure the difference between the intake temperature and the discharge is more than 8°C.

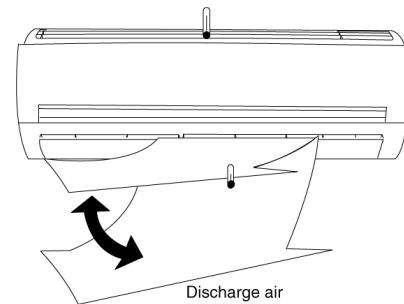

# 12 Operation And Control

## 12.1. Basic Function

Inverter control, which equipped with a microcomputer in determining the most suitable operating mode as time passes, automatically adjusts output power for maximum comfort always. In order to achieve the suitable operating mode, the microcomputer maintains the set temperature by measuring the temperature of the environment and performing temperature shifting. The compressor at outdoor unit is operating following the frequency instructed by the microcomputer at indoor unit that judging the condition according to internal setting temperature and intake air temperature.

### 12.1.1. Internal Setting Temperature

Once the operation starts, remote control setting temperature will be taken as base value for temperature shifting processes. These shifting processes are depending on the air conditioner settings and the operation environment. The final shifted value will be used as internal setting temperature and it is updated continuously whenever the electrical power is supplied to the unit.

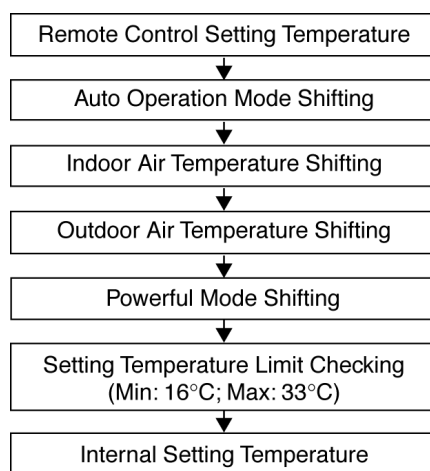

### 12.1.2. Airflow Direction

1. There are two types of airflow, vertical airflow (directed by horizontal vane) and horizontal airflow (directed by vertical vanes).
2. Control of airflow direction can be automatic (angles of direction is determined by operation mode, heat exchanger temperature and intake air temperature) and manual (angles of direction can be adjusted using remote control).

#### 12.1.2.1. Vertical Airflow

Operation Mode	Airflow Direction		Vane Angle (°)				
			1	2	3	4	5
Heating	Auto with Heat Exchanger Temperature	A Upward fix	3				
		B Downward fix	64				
		C Upward fix	3				
		D Downward fix	3				
	Manual		3	17	33	49	63
Cooling, Soft Dry and Ion	Auto		8 ~ 36				
	Manual		8	15	22	30	36
Mode Judgment in Auto	Auto		8				
	Manual		8	15	22	30	36

1. Automatic vertical airflow direction can be set using remote control; the vane swings up and down within the angles as stated above. For heating mode operation, the angle of the vane depends on the indoor heat exchanger temperature as Figure 1 below. When the air conditioner is stopped using remote control, the vane will shift to close position.
2. Manual vertical airflow direction can be set using remote control; the angles of the vane are as stated above and the positions of the vane are as Figure 2 below. When the air conditioner is stopped using remote control, the vane will shift to close position.

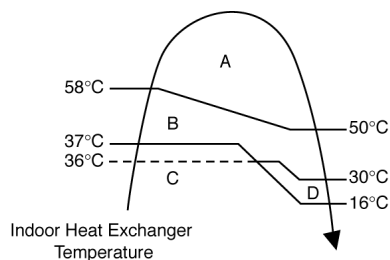

Figure 1

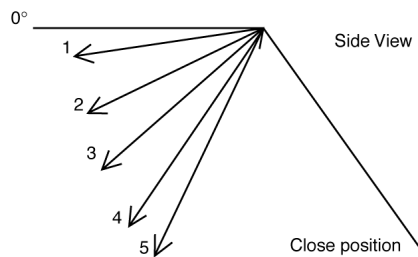

Figure 2

### 12.1.2.2. Horizontal Airflow

1. Automatic horizontal airflow direction can be set using remote control; the vane swings left and right within the angles as stated below. For heating mode operation, the angle of the vane depends on the indoor heat exchanger temperature as Figure 1 below.

Operation Mode		Vane Angle (°)
Heating, with heat exchanger temperature	A	65 ~ 115
	B	90
Cooling, Soft Dry and Ion		65 ~ 115

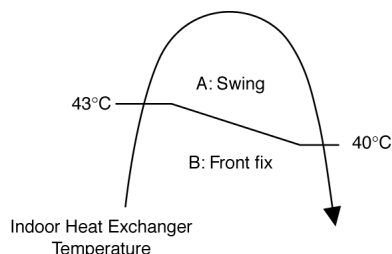

Figure 1

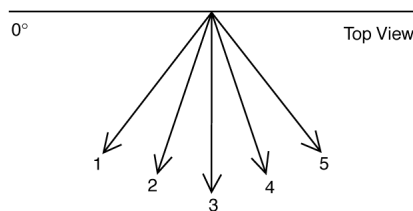

Figure 2

2. Manual horizontal airflow direction can be set using remote control; the angles of the vane are as stated below and the positions of the vane are as Figure 2 above.

Pattern	1	2	3	4	5
Airflow Direction Patterns at Remote Control					
Vane Angle (°)	90	65	78	102	115

### 12.1.3. Quiet operation (Cooling Mode/Cooling area of Dry Mode)

#### A. Purpose

To provide quiet cooling operation compare to normal operation.

#### B. Control condition

a. Quiet operation start condition

- When “quiet” button at remote control is pressed.  
Quiet LED illuminates.

b. Quiet operation stop condition

1. When one of the following conditions is satisfied, quiet operation stops:
  - a. Powerful button is pressed.
  - b. Stop by OFF/ON switch.
  - c. Timer “off” activates.
  - d. Quiet button is pressed again.

2. When quiet operation is stopped, operation is shifted to normal operation with previous setting.
3. When fan speed is changed, quiet operation is shifted to quiet operation of the new fan speed.
4. When operation mode is changed, quiet operation is shifted to quiet operation of the new mode.
5. During quiet operation, if timer "on" activates, quiet operation maintains.
6. After off, when on back, quiet operation is not memorised.

### C. Control contents

1. Fan speed is changed from normal setting to quiet setting of respective fan speed.  
This is to reduce sound of Hi, Me, Lo for 3dB.
2. Fan speed for quiet operation is -1 step from setting fan speed.

## 12.1.3.1. Quiet operation (Heating)

### A. Purpose

To provide quiet heating operation compare to normal operation.

### B. Control condition

- a. Quiet operation start condition
  - When "quiet" button at remote control is pressed.  
Quiet LED illuminates.
- b. Quiet operation stop condition
  1. When one of the following conditions is satisfied, quiet operation stops:
    - a. Powerful button is pressed.
    - b. Stop by OFF/ON switch.
    - c. Timer "off" activates.
    - d. Quiet button is pressed again.
  2. When quiet operation is stopped, operation is shifted to normal operation with previous setting.
  3. When fan speed is changed, quiet operation is shifted to quiet operation of the new fan speed.
  4. When operation mode is changed, quiet operation is shifted to quiet operation of the new mode, except fan only mode.
  5. During quiet operation, if timer "on" activates, quiet operation maintains.
  6. After off, when on back, quiet operation is not memorised.

### C. Control contents

- a. Fan Speed manual
  1. Fan speed is changed from normal setting to quiet setting of respective fan speed.  
This is to reduce sound of Hi, Me, Lo for 3dB.
  2. Fan speed for quiet operation is -1 step from setting fan speed.
  3. Fan Speed Auto  
Indoor FM RPM depends on pipe temp sensor of indoor heat exchanger.

### 12.1.4. Powerful Mode Operation

When the powerful mode is selected, the internal setting temperature will shift to achieve the setting temperature quickly.

(a) Cooling Operation

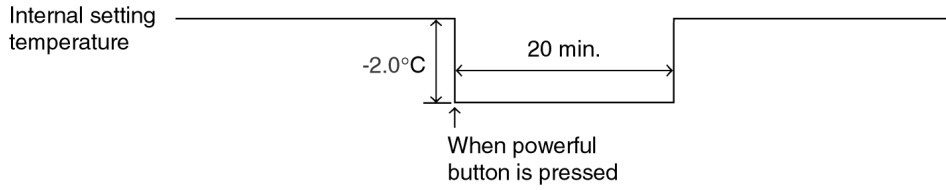

(b) Soft Dry Operation

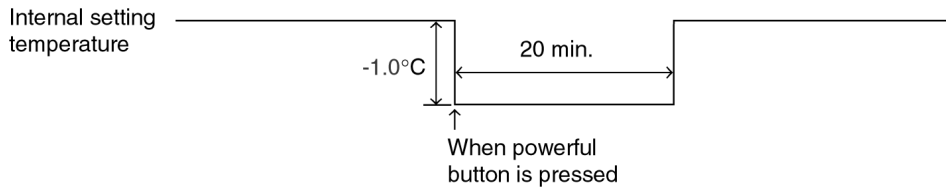

(c) Heating Operation

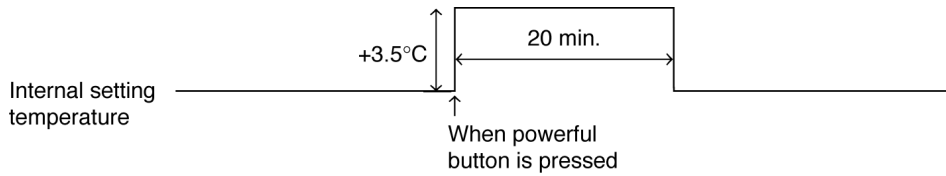

### 12.1.5. ON Timer Control

ON timer can be set using remote control, the unit with timer set will start operate earlier than the setting time. This is to provide a comfortable environment when reaching the set ON time.

60 minutes before the set time, indoor (at fan speed of Lo-) and outdoor fan motor start operate for 30 seconds to determine the indoor intake air temperature and outdoor air temperature in order to judge the operation starting time.

From the above judgment, the decided operation will start operate earlier than the set time as shown below.

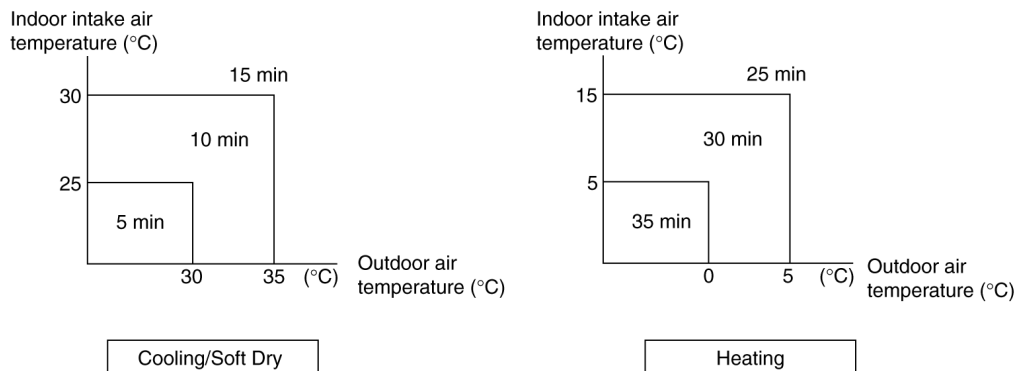

### 12.1.6. OFF Timer Control

OFF timer can be set using remote control, the unit with timer set will stop operate at set time.

### 12.1.7. Auto Restart Control

1. When the power supply is cut off during the operation of air conditioner, the compressor will re-operate within three to four minutes (there are 10 patterns between 2 minutes 58 seconds and 3 minutes 52 seconds to be selected randomly) after power supply resumes.
2. This type of control is not applicable during ON/OFF Timer setting.

### 12.1.8. Ionizer Operation

**Purpose**

To provide fresh air effect to users by discharging minus ion to air.

**Control Condition**

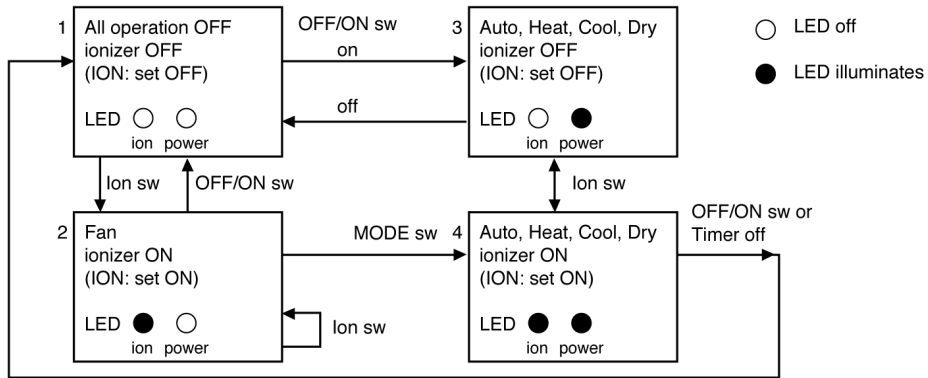

a. Ionizer Only Operation.

1. When air-conditioner unit is at "OFF" condition (standby) and ION operation button at remote control is pressed. Fan & ionizer on, ION LED illuminates, but power LED maintain off. (1 → 2)  
However, fan speed can be adjusted later by customer during this operation.

Fan speed	
manual	Remote Control set fan speed
Auto	Repetition of 8 patterns as shown below

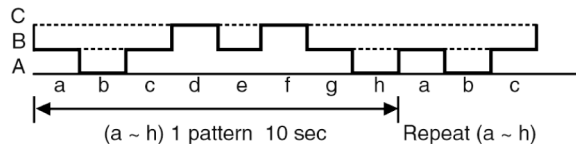

Airflow direction (Horizontal Vane) control:  
Follow vane direction control at cooling mode.  
Horizontal vane can be changed by customer during ion only operation.

b. Operation Mode + Ionizer Operation.

1. Ionising Operation Start Condition

When air conditioner unit is in "ON" condition (Heat, Cool, Dry, Auto mode) and ION operation button at remote control is pressed. Ionizer on & ION LED illuminates. (3 → 4)  
Power LED also illuminates.

2. Ionising Operation Stop Condition

When one of the following condition is satisfied, ION operation stops.

- a. Stopped by ON/OFF switch.
- b. Timer OFF activates.
- c. ION feedback signal shows error.

3. Ionizer operation status is not memorised by micon. After OFF, when operation is "ON" again, air conditioner operates without ionizer operation.

## 12.2. Protection Control

### 12.2.1. Time Delay Safety Control

- Compressor will not start for three minutes after stop of the operation.

### 12.2.2. 30 Seconds Forced Operation

- Once compressor starts the operation, it will not stop its operation for 30 seconds. However, it can be stopped with the remote controller or the Auto button on the indoor unit.

### 12.2.3. Total Running Current Control

1. When the total running current exceeds I1, compressor operation frequency is reduced. If it reaches below I1, the operation frequency is increased. (But, up to programmed frequency.)
2. If total running current exceeds I2, compressor is stopped immediately.
3. If it happens three (3) times within 20 minutes, operation will be stopped and Timer LED blinks. ("F98" is activating.)

	Running current	CS-E9EKEB	CS-E12EKEB
Cooling	I1	3.7A	5.8A
	I2	25.0A	25.0A
Heating	I1	5.9A	8.2A
	I2	25.0A	25.0A

### 12.2.4. IPM (Power transistor) Protection Control (DC Peak detection)

#### Abnormal Current Control

- If inverter load current (DC peak) exceeds a rated value, compressor will be stopped immediately. When the excess occurs within 30 seconds after operation, it restarts in 1 minute and when after 30 seconds, restarts in 2 minutes.
- If the excess continuously occurs 7 times within 30 minutes after compressor starts, the unit will be stopped and timer LED on the indoor unit will be blinking. ("F99" is to be confirmed.)

#### IPM Overheating Prevention Control

- If temperature of IPM exceeds 103°C, compressor will be stopped. It will restart in 2 minutes. Temperature for restarting: 90°C.
- If the excess occurs 4 times within 30 minutes after compressor starts, the compressor will be stopped and timer LED on the indoor unit will be blinking. ("F96" is to be confirmed.)

### 12.2.5. Compressor Overheating Prevention Control

1. If discharge pipe temperature exceeds 100°C, compressor power will be limited.
2. If discharge pipe temperature exceeds 112°C, compressor will be stopped.
3. If the above excess occurs 4 times per 10 minutes, timer LED will be blinking. ("F97" is to be confirmed.)

### 12.2.6. Outdoor High Pressure Prevention Control (Cooling and Dry operations)

1. If outdoor heat exchanger temperature exceeds 63°C in cooling or dry operation, compressor will be stopped.
2. Timer LED is not blinking. ("F95" is memorized, then.)

### 12.2.7. Compressor Protection Control (Refrigeration Cycle Abnormality)

#### In cooling and Dry operations

1. When compressor is operated continuously for 5 minutes in the maximum cooling power: a running current of 0.7 - 1.4A and "[Indoor intake air temperature] - [Indoor heat exchanger temperature]" < 4°C, compressor will be stopped.
2. If the above excess occurs twice for 20 minutes, timer LED is to be blinking. ("F91" is to be confirmed.)

#### In Heating operation

1. When compressor is operated continuously for 5 minutes in the rated heating power: a running current of 0.7 - 1.4A and "[Indoor heat exchanger temperature] - [Indoor intake air temperature]" < 5°C, compressor will be stopped.
2. If the above excess occurs twice for 20 minutes, timer LED is to be blinking. ("F91" is to be confirmed.)

## 12.2.8. Four-way Valve Operation Detection Control (Switching Abnormality between Cooling and Heating)

### In Cooling operation

1. When indoor heat exchanger temperature exceeds 45°C in 4 minutes after compressor starts, compressor will be stopped.
2. If the above excess occurs 4 times per 30 minutes, timer LED is to be blinking. ("F11" is to be confirmed.)

### In Heating operation

1. When indoor heat exchanger temperature is below 0°C in 4 minutes after compressor starts, compressor will be stopped.
2. If the above excess occurs 4 times per 30 minutes, timer LED is to be blinking. ("F11" is to be confirmed.)

## 12.2.9. Anti-Freezing Control (Cooling and Dry operations)

### Limit of Cooling power

1. When temperature of indoor heat exchanger is below 5°C, operating frequency will be decreased.
2. When temperature of indoor heat exchanger exceeds 7°C, operating frequency will be increased. (But, up to programmed frequency.)
3. When temperature of indoor heat exchanger is below 0°C continuously for 6 minutes, compressor will be stopped.
4. Timer LED is not blinking. ("F99" is memorized, then.)

### Limit of Indoor fan speed

- When temperature of indoor heat exchanger is below 6°C (2°C at Dry) continuously for 6 minutes, indoor fan speed will be increased by 50 rpm.

## 12.2.10. Outdoor Air Temperature Control

### In Cooling and Dry operations

1. When outdoor air temperature is below 25°C, the maximum power will be limited up to about 80 - 100% of the rated power.
2. When outdoor air temperature is below 18°C, the maximum power will be limited up to about 50 - 100% of the rated power.
3. When outdoor air temperature is below 11°C, the maximum power will be limited up to about 26 - 81% of the rated power.

## 12.2.11. Indoor Intake Air Temperature Control (Heating operation)

1. When indoor air temperature is 35°C or more, the maximum power will be limited up to the rated power.
2. When fan speed is set at "Lo" and intake air temperature is below 21°C, the maximum power will be limited up to the rated power.



## 13 Servicing Mode

### 13.1. Auto Switch Operation

The below operations will be performed by pressing the "AUTO" switch.

#### 1. AUTO OPERATION MODE

The Auto operation will be activated immediately once the Auto Switch is pressed.

#### 2. TEST RUN OPERATION (FOR PUMP DOWN/SERVICING PURPOSE)

The Test Run operation will be activated if the Auto Switch is pressed continuously for more than 5 sec. A "beep" sound will occur at the fifth sec., in order to identify the starting of Test Run operation.

#### 3. REMOTE CONTROLLER RECEIVING SOUND ON/OFF

The ON/OFF of remote controller receiving sound can be change over by pressing the following step:

a. Release the Auto Switch after Test Run operation is activated.

b. Then, within 20 sec., after a., press Auto Switch for more than 5 sec.

A "beep" "beep" sound will occur at the fifth sec., then release the Auto Switch.

c. Within 20 sec. after b., press Auto Switch again. Everytime Auto Switch is pressed (within 20 sec. interval), remote controller receiving sound status will be reversed between ON and OFF.

Long "beep" sound indicates that remote controller receiving sound is OFF.

Short "beep" sound indicates that remote controller receiving sound is ON.

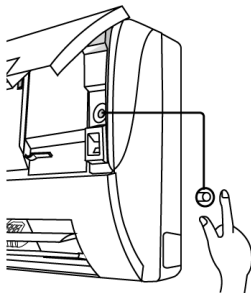

### 13.2. Indicator Panel

(green) (orange) (orange) (orange) (green) (blue)





  
**POWER** **TIMER** **QUIET** **POWERFUL** **ION** **SUPER ALLERU-BUSTER**

LED	POWER	TIMER	QUIET	POWERFUL	ION	ALLERGEN BUSTER
Color	Green	Orange	Orange	Orange	Green	Blue
Light ON	Operation ON	Timer Setting ON	Quiet Mode ON	Powerful Mode ON	Ion Mode ON	Operation ON
Light OFF	Operation OFF	Timer Setting OFF	Quiet Mode OFF	Powerful Mode OFF	Ion Mode OFF	Operation OFF

Note:

- If POWER LED is blinking, the possible operations of the unit are Hot Start, during Deice operation, operation mode judgment, or ON timer sampling.
- If Timer LED is blinking, there is an abnormality operation occurs.
- If Ionizer, LED is blinking, there is an abnormality of Ionizer occurs.

# 14 Troubleshooting Guide

## 14.1. Refrigeration Cycle System

In order to diagnose malfunctions, make sure that there are no electrical problems before inspecting the refrigeration cycle. Such problems include insufficient insulation, problem with the power source, malfunction of a compressor and a fan.

The normal outlet air temperature and pressure of the refrigeration cycle depends on various conditions, the standard values for them are shown in the table to the right.

Normal Pressure and Outlet Air Temperature (Standard)

	Gas pressure MPa (kg/cm <sup>2</sup> G)	Outlet air temperature (°C)
Cooling Mode	0.9 ~ 1.2 (9 ~ 12)	12 ~ 16
Heating Mode	2.3 ~ 2.9 (23 ~ 29)	36 ~ 45

- ★ Condition:
- Indoor fan speed; High
  - Outdoor temperature 35°C at cooling mode and 7°C at heating mode.
  - Compressor operates at rated frequency

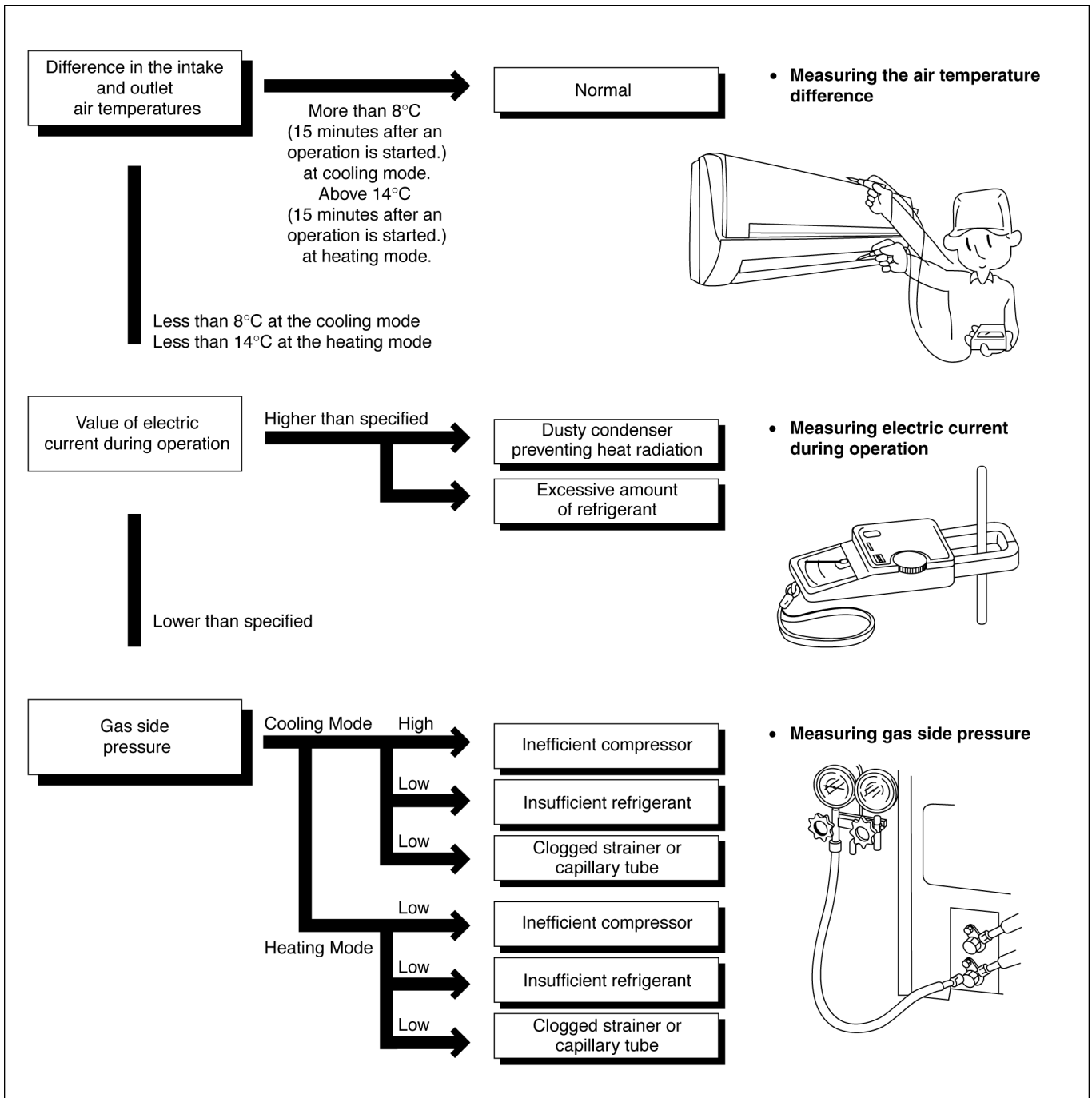

## 14.2. Relationship Between The Condition Of The Air Conditioner And Pressure And Electric Current

Condition of the air conditioner	Cooling Mode			Heating Mode		
	Low Pressure	High Pressure	Electric current during operation	Low Pressure	High Pressure	Electric current during operation
Insufficient refrigerant (gas leakage)	↘	↘	↘	↘	↘	↘
Clogged capillary tube or Strainer	↘	↘	↘	↗	↗	↗
Short circuit in the indoor unit	↘	↘	↘	↗	↗	↗
Heat radiation deficiency of the outdoor unit	↗	↗	↗	↘	↘	↘
Inefficient compression	↗	↘	↘	↗	↘	↘

- Carry on the measurements of pressure, electric current, and temperature fifteen minutes after an operation is started.

## 14.3. Breakdown Self Diagnosis Function

Once abnormality detected during operation, the unit will immediately stop its operation (Timer LED is blinking) and maximum of three error codes (abnormality) will be saved in memory. The abnormality of the operation can be identified through the below breakdown diagnosis method:

- Press "CHECK" button at remote controller continuously for more than five seconds to turn on the diagnosis mode, "H11" will be displayed at remote controller.
- By pressing the TMER "∧" button once, next error code will be displayed; press "V" button once, previous error code will be displayed.
- If error code displayed matches the error code saved in unit memory (abnormality detected), "beep, beep, beep...." sounds will be heard for 4 seconds and Power LED will light on. Otherwise, one "beep" sound is heard.

If "CHECK" button is press again or without any operation for 30 seconds, the diagnosis mode will turn off.

## 14.4. Error Codes Table

Diagnosis display	Abnormality / Protection control	Abnormality Judgement	Emergency operation	Primary location to verify
H00	No abnormality detected	—	Normal operation	—
H11	Indoor / outdoor abnormal communication	> 1 min after starting operation	Indoor fan operation only	<ul style="list-style-type: none"> <li>• Internal / external cable connections</li> <li>• Indoor / Outdoor PCB</li> </ul>
H12	Connection capability rank abnormal	—	—	—
H14	Indoor intake air temperature sensor abnormality	Continue for 5 sec.	—	<ul style="list-style-type: none"> <li>• Intake air temperature sensor (detective or disconnected)</li> </ul>
H15	Outdoor compressor temperature sensor abnormality	Continue for 5 sec.	—	<ul style="list-style-type: none"> <li>• Compressor temperature sensor (detective or disconnected)</li> </ul>
H16	Outdoor Current Transformer open circuit	—	—	<ul style="list-style-type: none"> <li>• Outdoor PCB</li> <li>• IPM (Power transistor) module</li> </ul>
H19	Indoor fan motor mechanism locked	—	—	<ul style="list-style-type: none"> <li>• Indoor PCB</li> <li>• Fan motor</li> </ul>
H23	Indoor heat exchanger temperature sensor abnormality	Continue for 5 sec.	O (Cooling only)	<ul style="list-style-type: none"> <li>• Heat exchanger temperature sensor (defective or disconnected)</li> </ul>
H26	Ionizer breakdown	—	—	<ul style="list-style-type: none"> <li>• Ionizer</li> </ul>
H27	Outdoor intake air temperature sensor abnormality	Continue for 5 sec.	O	<ul style="list-style-type: none"> <li>• Outdoor temperature sensor (defective or disconnected)</li> </ul>
H28	Outdoor heat exchanger temperature sensor abnormality	Continue for 5 sec.	O	<ul style="list-style-type: none"> <li>• Outdoor heat exchanger temperature sensor (defective or disconnected)</li> </ul>
H30	Outdoor discharge air temperature sensor abnormality	Continue for 5 sec.	—	<ul style="list-style-type: none"> <li>• Outdoor temperature sensor (defective or disconnected)</li> </ul>
H33	Indoor/Outdoor wrong connection	—	—	<ul style="list-style-type: none"> <li>• Indoor/Outdoor supply voltage</li> </ul>
H38	Indoor / outdoor mismatch (brand code)	—	—	—
H97	Outdoor fan motor mechanism locked	2 times occurrence within 30 minutes	—	<ul style="list-style-type: none"> <li>• Indoor PCB</li> <li>• Fan motor</li> </ul>
H98	Indoor high pressure protection	—	—	<ul style="list-style-type: none"> <li>• Air filter dirty</li> <li>• Air circulation short circuit</li> </ul>
H99	Indoor heat exchanger anti-freezing protection	—	—	<ul style="list-style-type: none"> <li>• Insufficient refrigerant</li> <li>• Air filter dirty</li> </ul>
F11	Cooling / Heating cycle changeover abnormality	4 times occurrence within 30 minutes	—	<ul style="list-style-type: none"> <li>• 4-way valve</li> <li>• V-coil</li> </ul>
F90	PFC control	4 times occurrence within 10 minutes	—	<ul style="list-style-type: none"> <li>• Voltage at PFC</li> </ul>
F91	Refrigeration cycle abnormality	2 times occurrence within 20 minutes	—	<ul style="list-style-type: none"> <li>• No refrigerant (3-way valve is closed)</li> </ul>
F93	Compressor rotation failure	—	—	<ul style="list-style-type: none"> <li>• Compressor</li> </ul>
F95	Cool high pressure protection	4 times occurrence within 20 minutes	—	<ul style="list-style-type: none"> <li>• Outdoor refrigerant circuit</li> </ul>
F96	IPM (power transistor) overheating protection	—	—	<ul style="list-style-type: none"> <li>• Excess refrigerant</li> <li>• Improper heat radiation</li> <li>• IPM (Power transistor)</li> </ul>
F97	Outdoor compressor overheating protection	4 times occurrence within 10 minutes	—	<ul style="list-style-type: none"> <li>• Insufficient refrigerant</li> <li>• Compressor</li> </ul>
F98	Total running current protection	3 times occurrence within 20 minutes	—	<ul style="list-style-type: none"> <li>• Excess refrigerant</li> <li>• Improper heat radiation</li> </ul>
F99	Outdoor Direct Current (DC) peak detection	7 times occurrence continuously	—	<ul style="list-style-type: none"> <li>• Outdoor PCB</li> <li>• IPM (Power transistor)</li> <li>• Compressor</li> </ul>

Note:

“O” - Frequency measured and fan speed fixed.

The memory data of error code is erased when the power supply is cut off, or press the Auto Switch until “beep” sound heard following by pressing the “RESET” button at remote controller.

Although operation forced to stop when abnormality detected, emergency operation is possible for certain errors (refer to Error Codes Table) by using remote controller or Auto Switch at indoor unit. However, the remote controller signal receiving sound is changed from one “beep” to four “beep” sounds.

## 15 Disassembly and Assembly Instructions

### WARNING

- Caution! When handling electronic controller, be careful of electrostatic discharge.
- Be sure to return the wiring to its original position.
- There are many high voltage components within the heat sink cover so never touch the interior during operation. Wait at least two minutes after power has been turned off.

### 15.1. Indoor Electronic Controller and Control Board

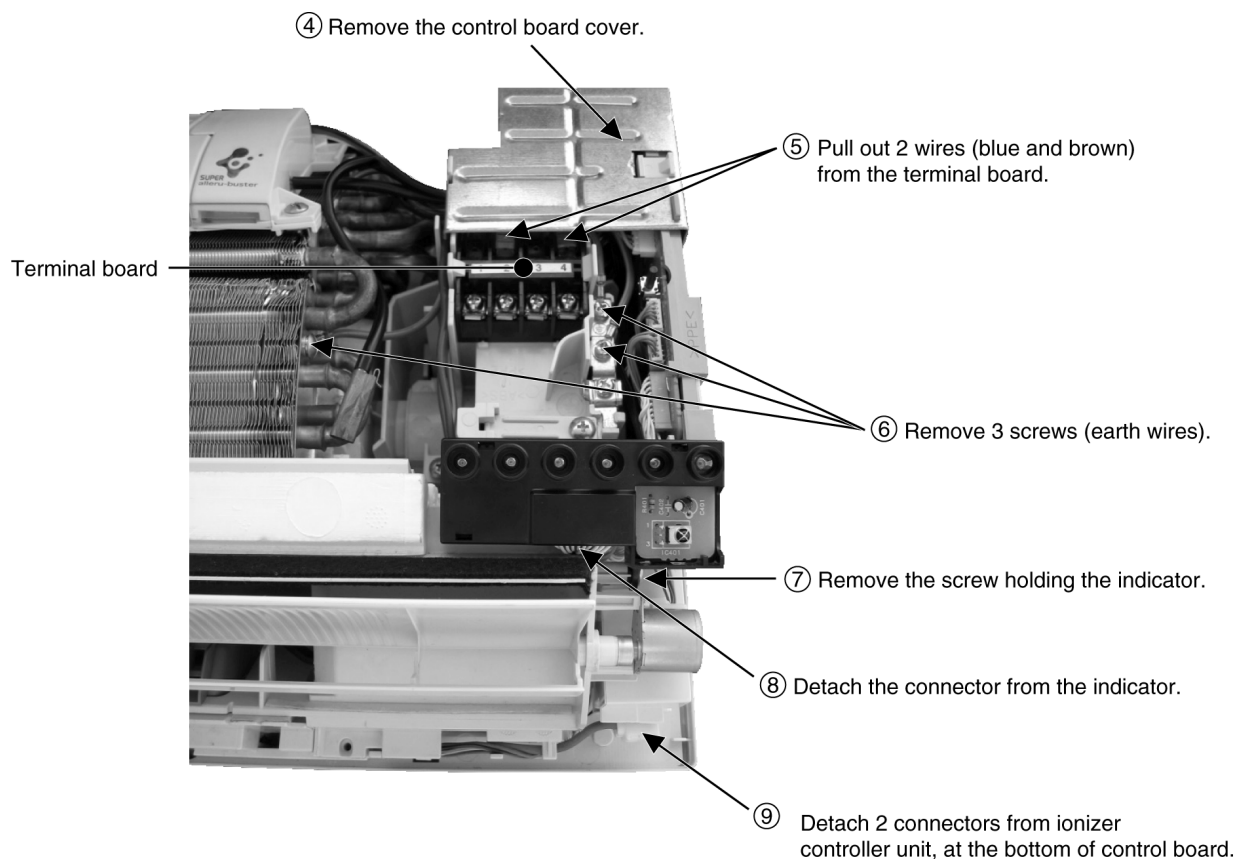
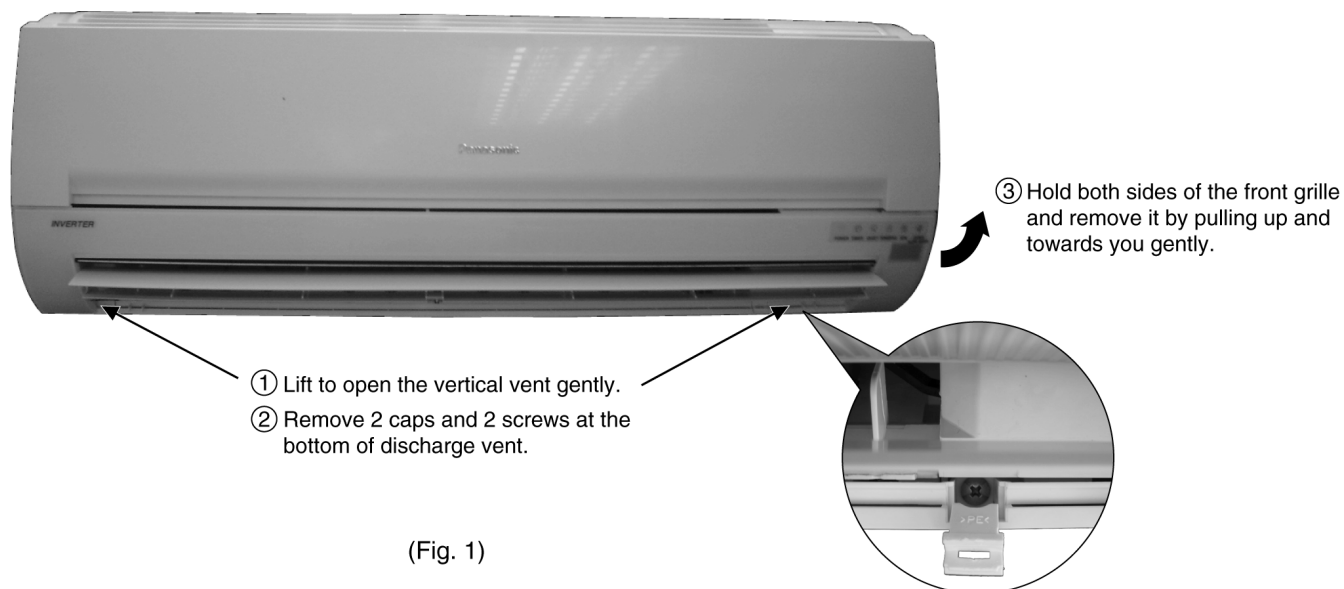

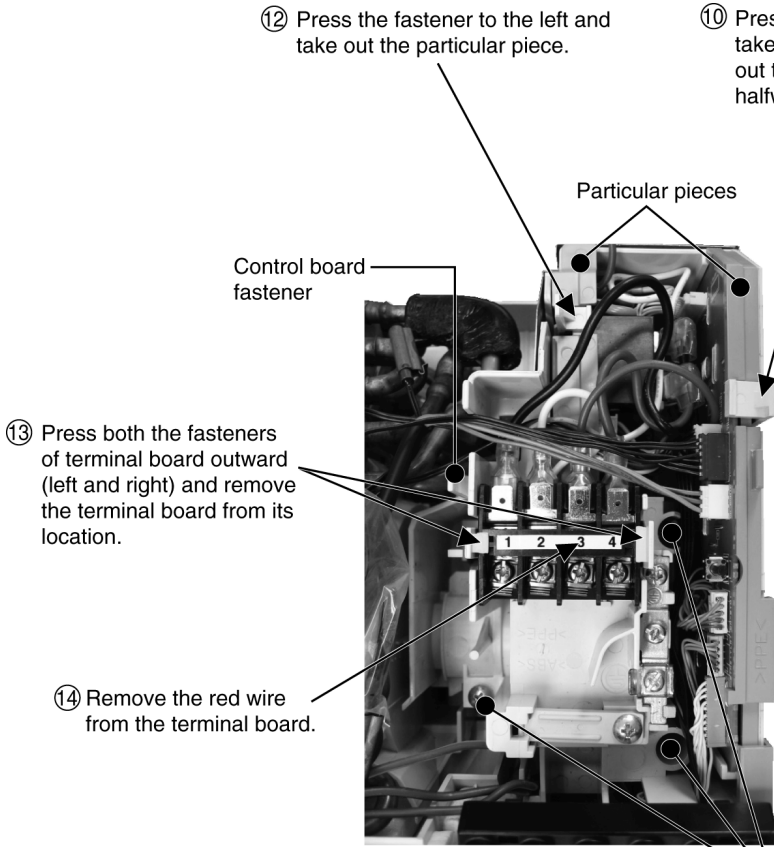

(Fig. 3)

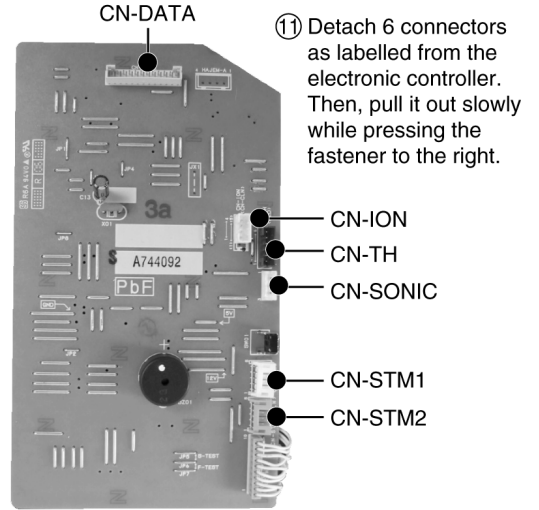

(Fig. 4)

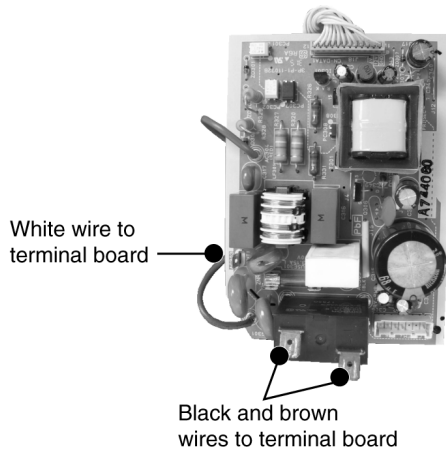

⑮ Detach 3 wires and one connector as labelled from the electronic controller. Then, pull it out slowly while pressing the fastener to the left.

(Fig. 5)

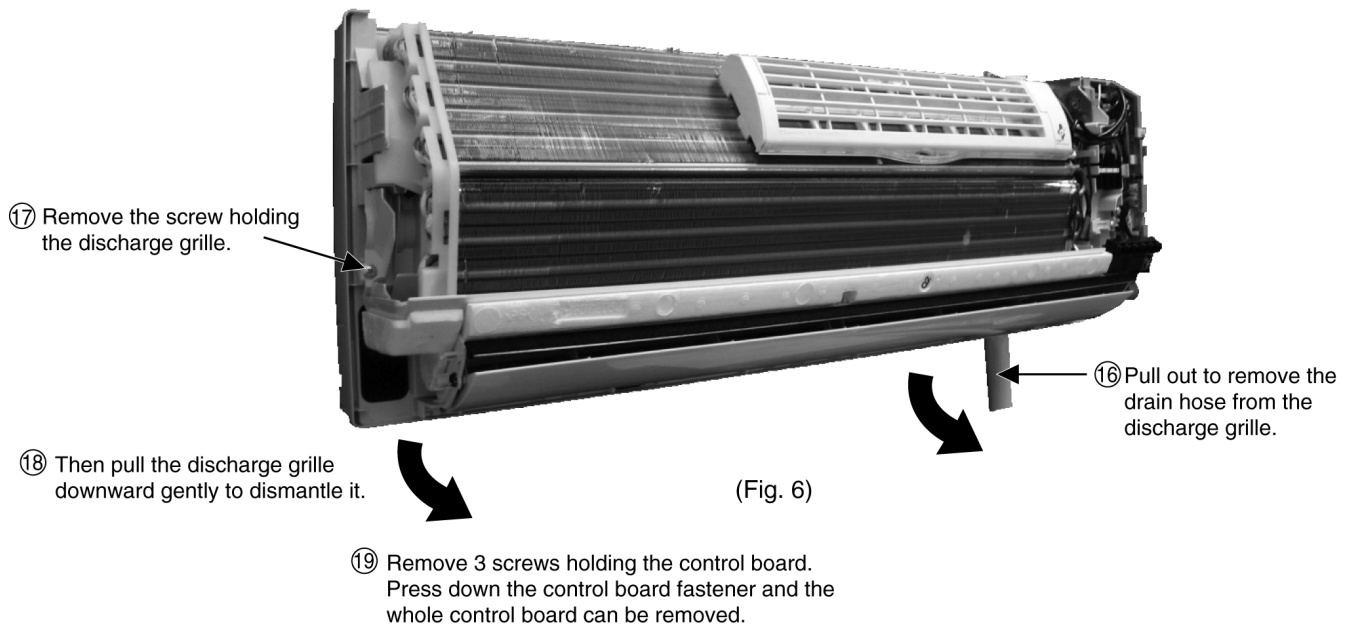

## 15.2. Indoor Cross Flow Fan and Fan Motor

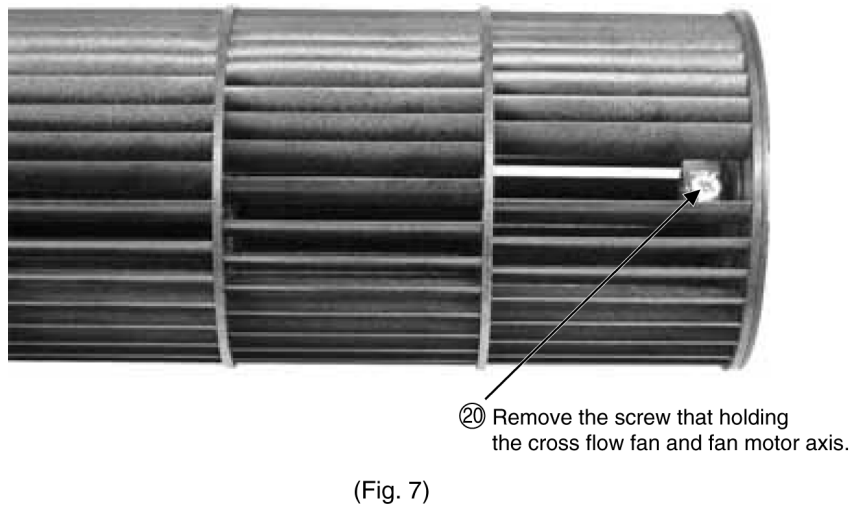

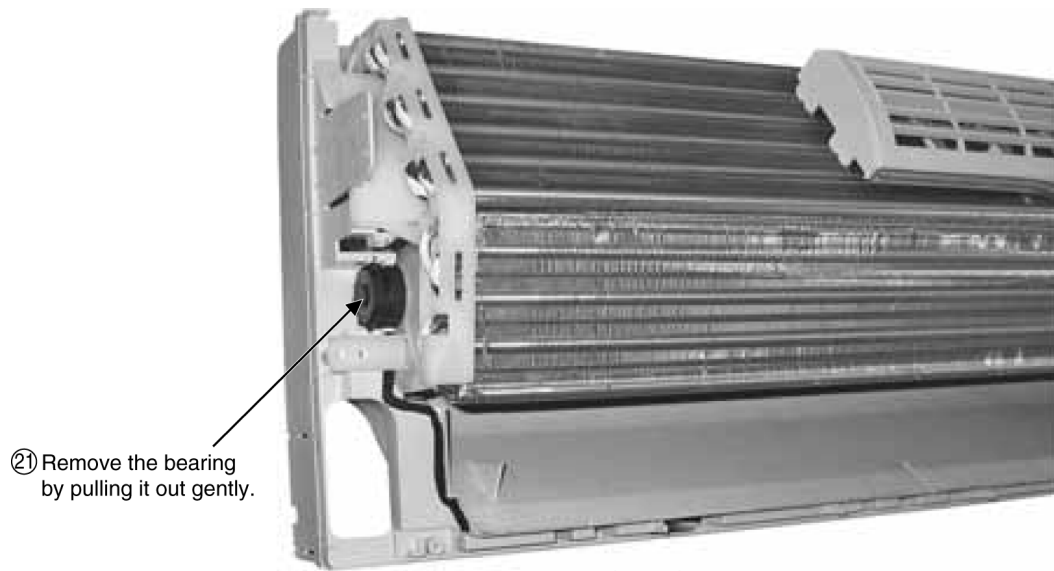

⑳ Remove the bearing by pulling it out gently.

(Fig. 8)

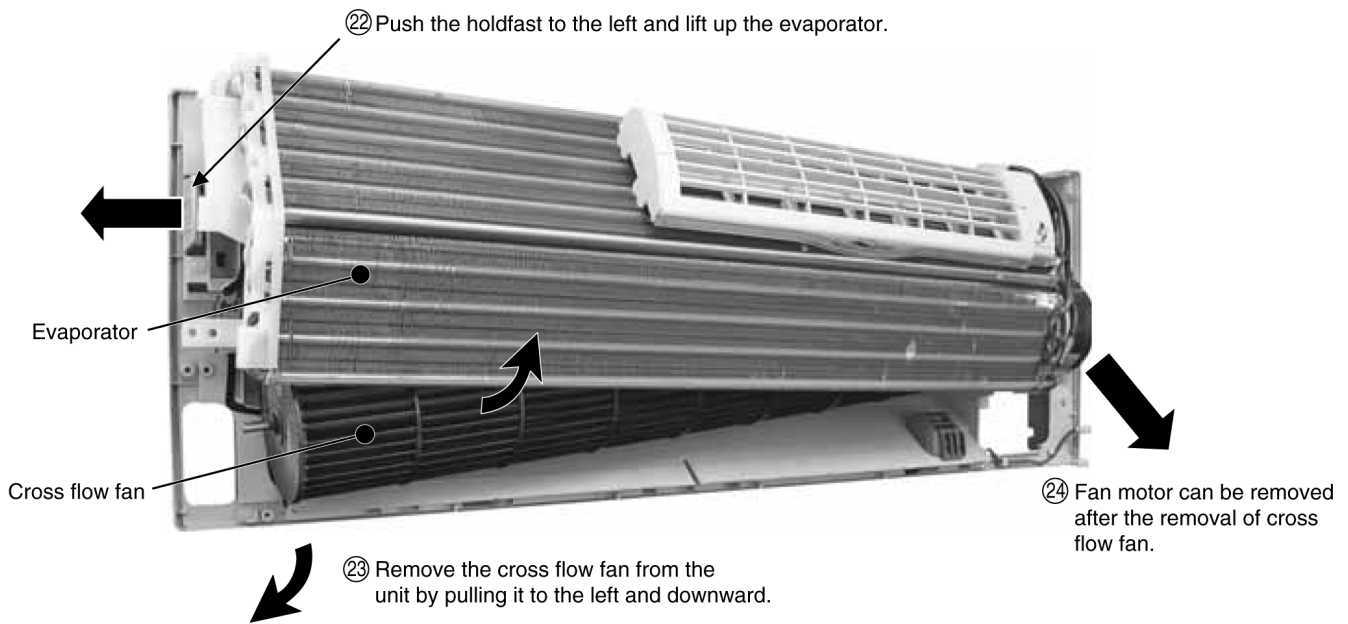

(Fig. 9)



### 15.3. Outdoor Propeller Fan and Fan Motor

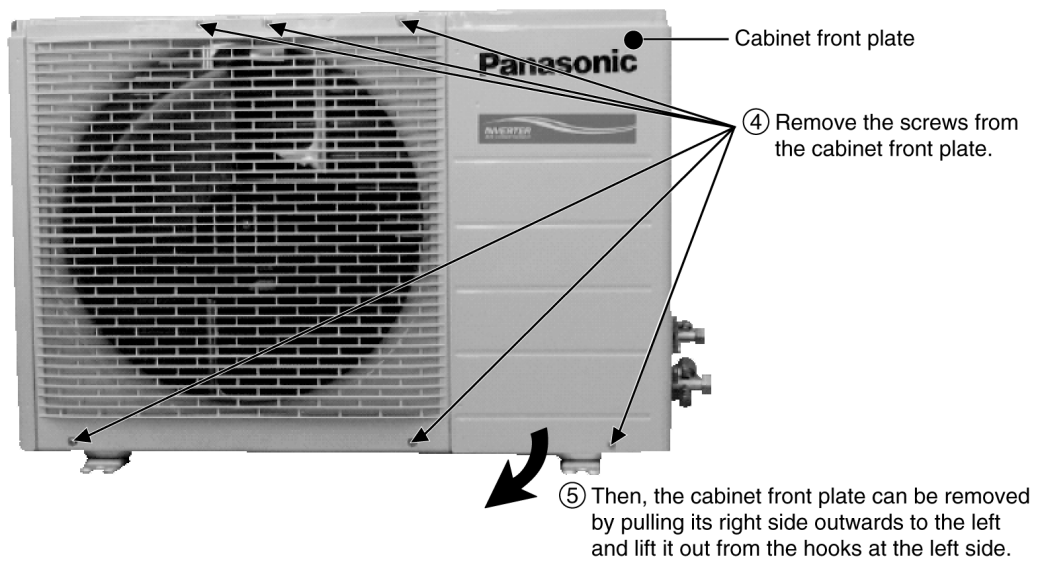
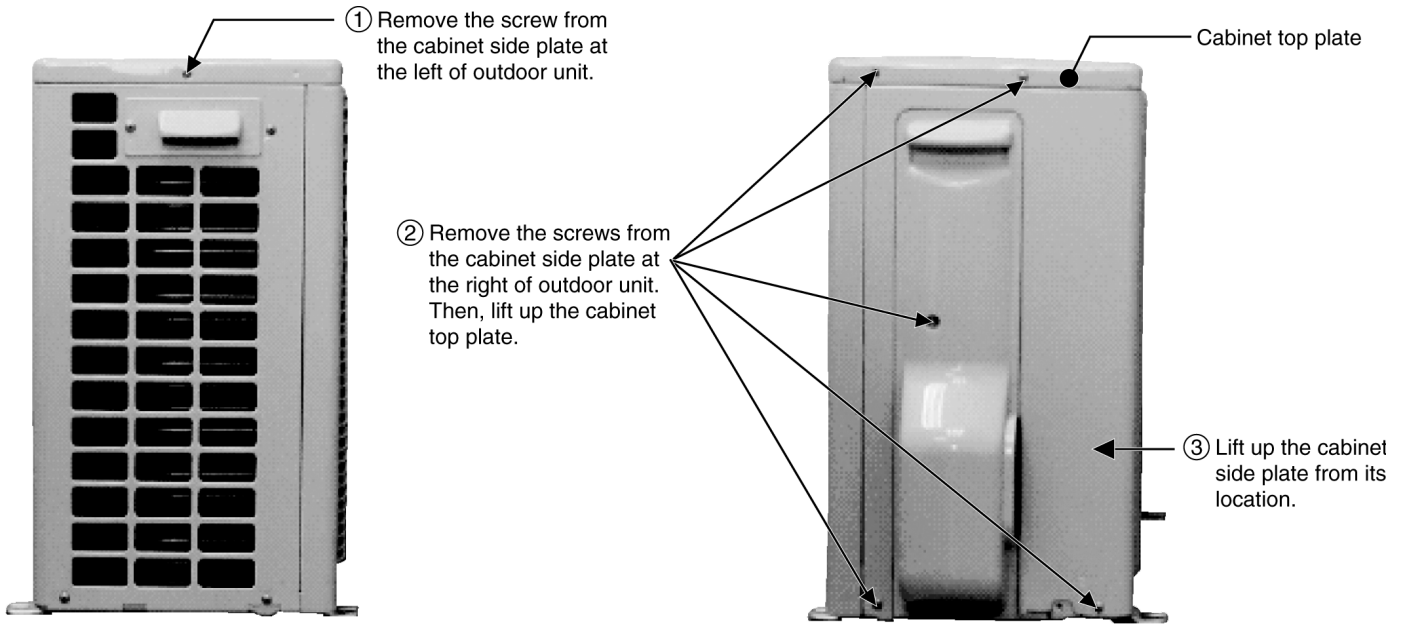

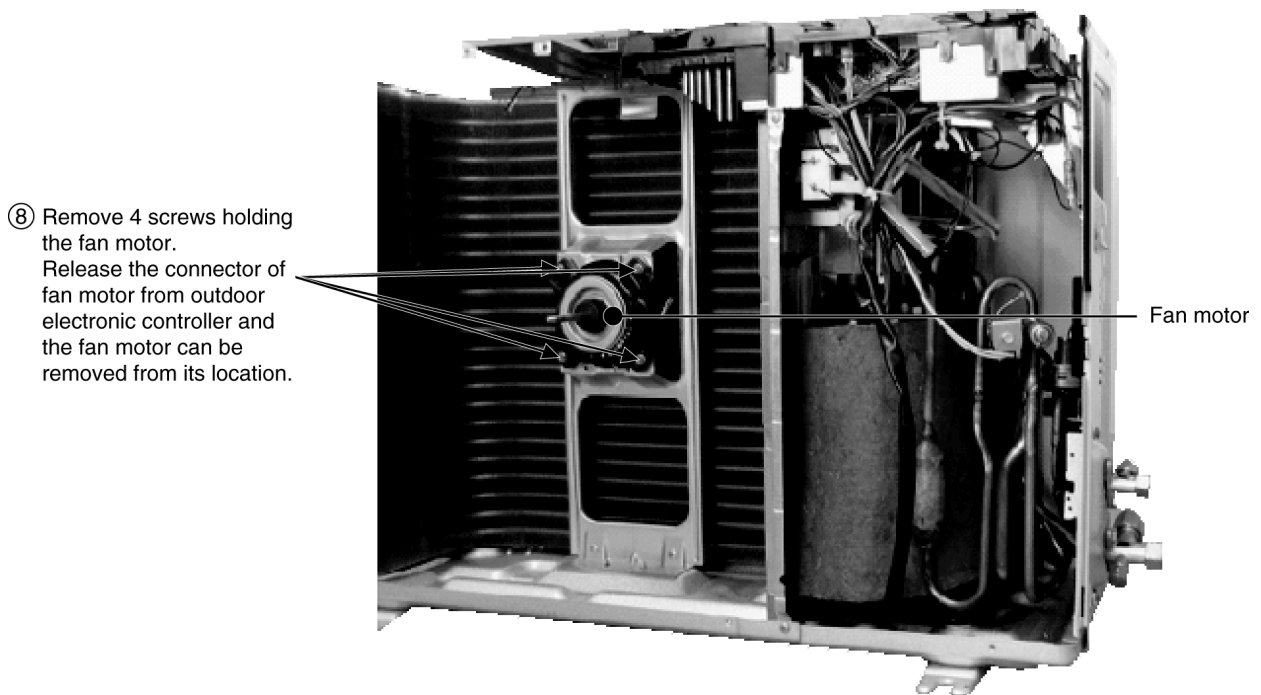
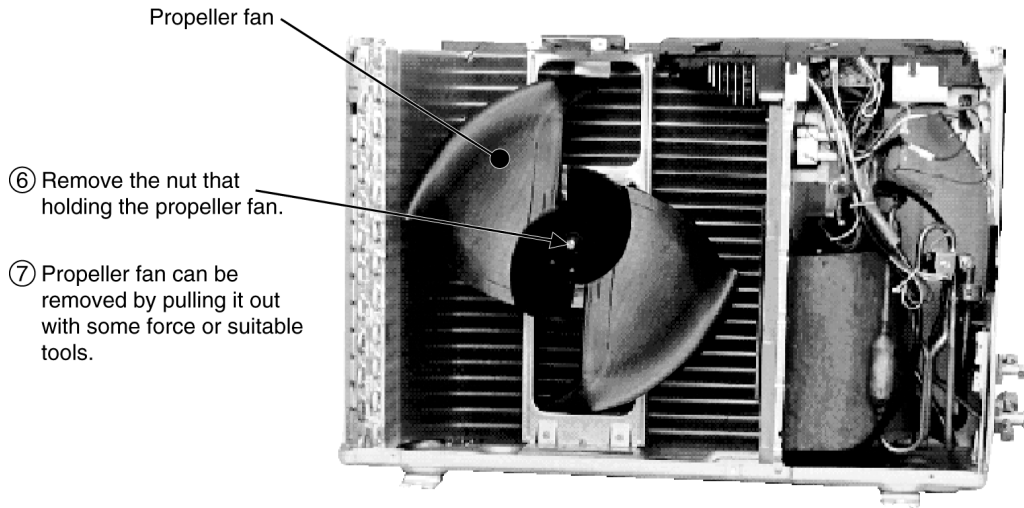

# 16 Technical Data

## 16.1. CS-E9EKEB CU-E9EKEB

### Cooling Characteristic at Different Outdoor Air Temperature

#### Condition

Indoor room temperature: 27/19 °C

Remote control setting: HI fan, COOL 16 °C

Compressor frequency: rated cooling

Voltage: 230 V

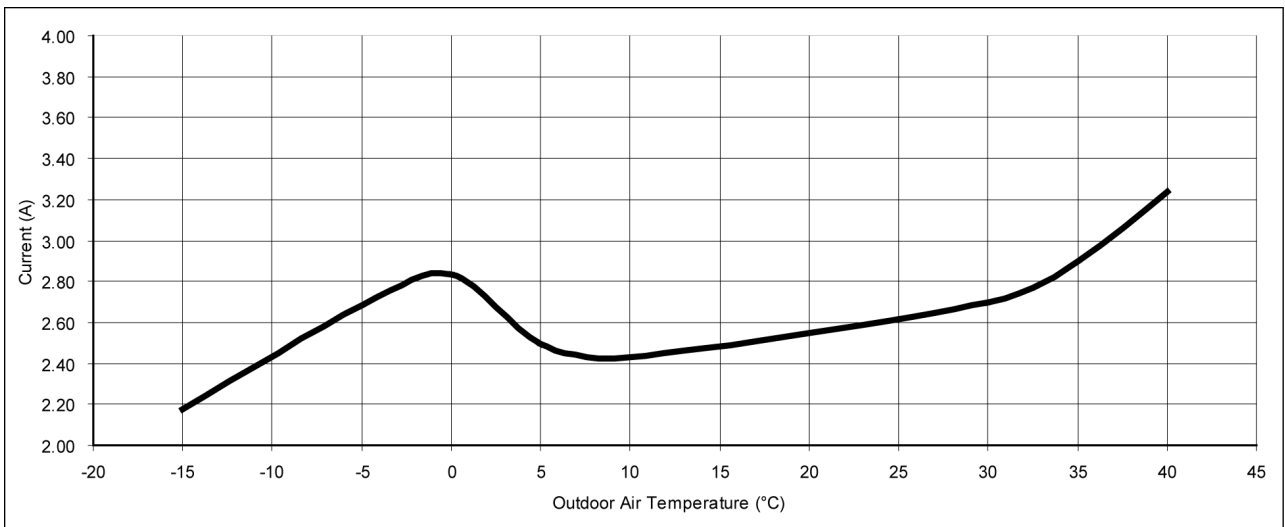
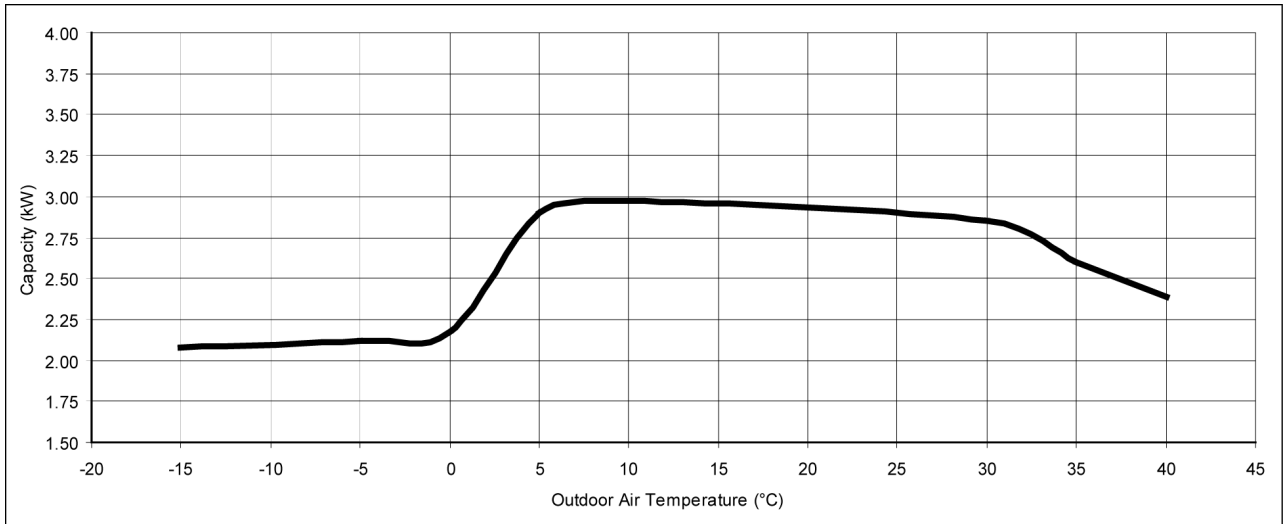

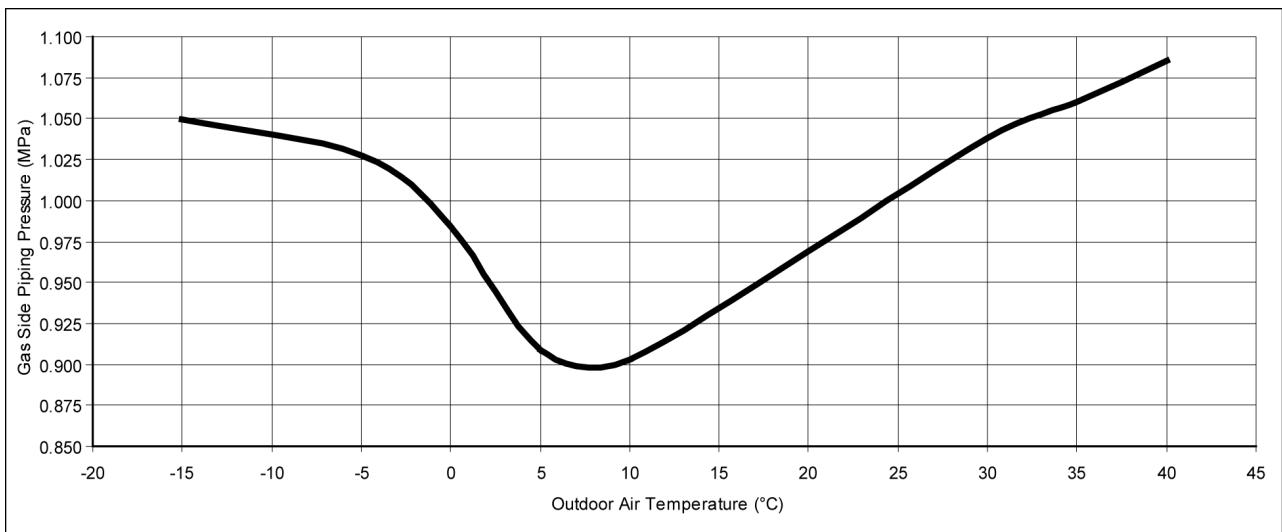
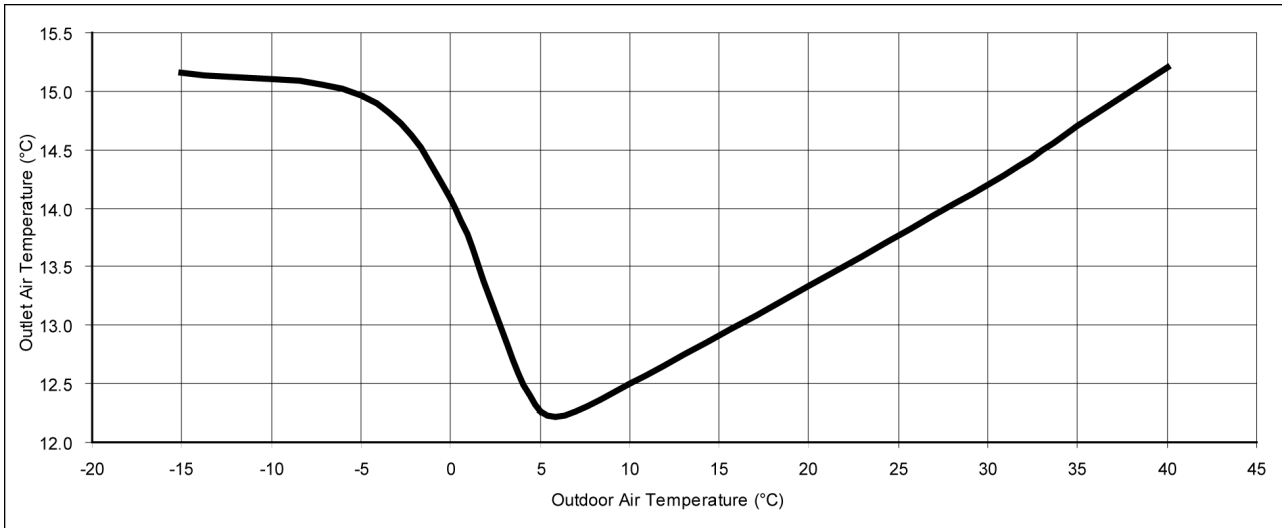

**Heating Characteristic at Different Outdoor Air Temperature**

**Condition**

Indoor room temperature: 20 °C

Remote control setting: HI fan, HEAT 30 °C

Compressor frequency: rated heating

Voltage: 230 V

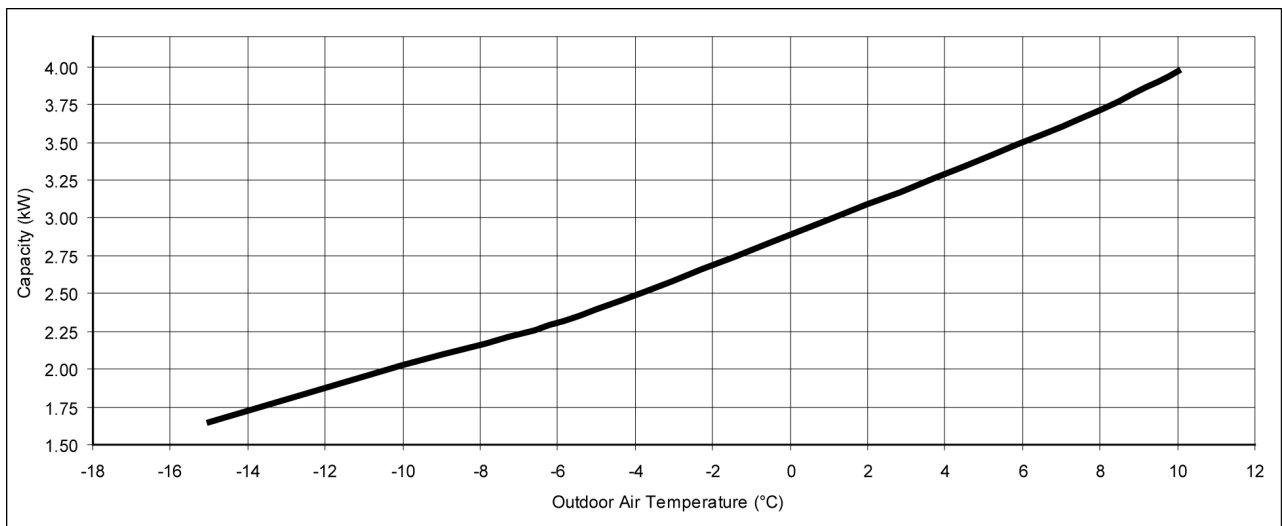

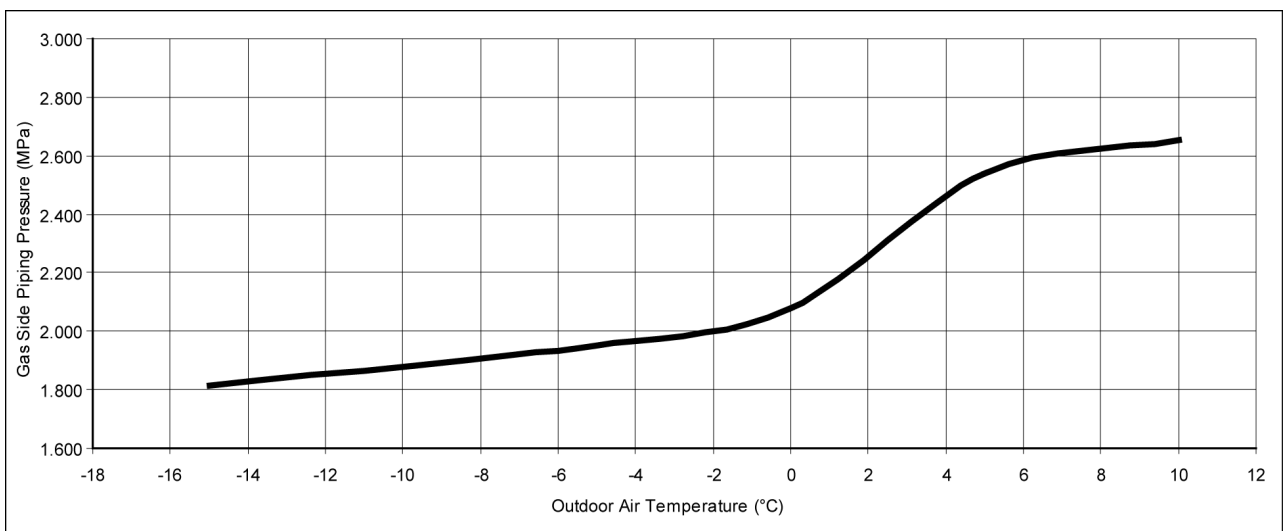
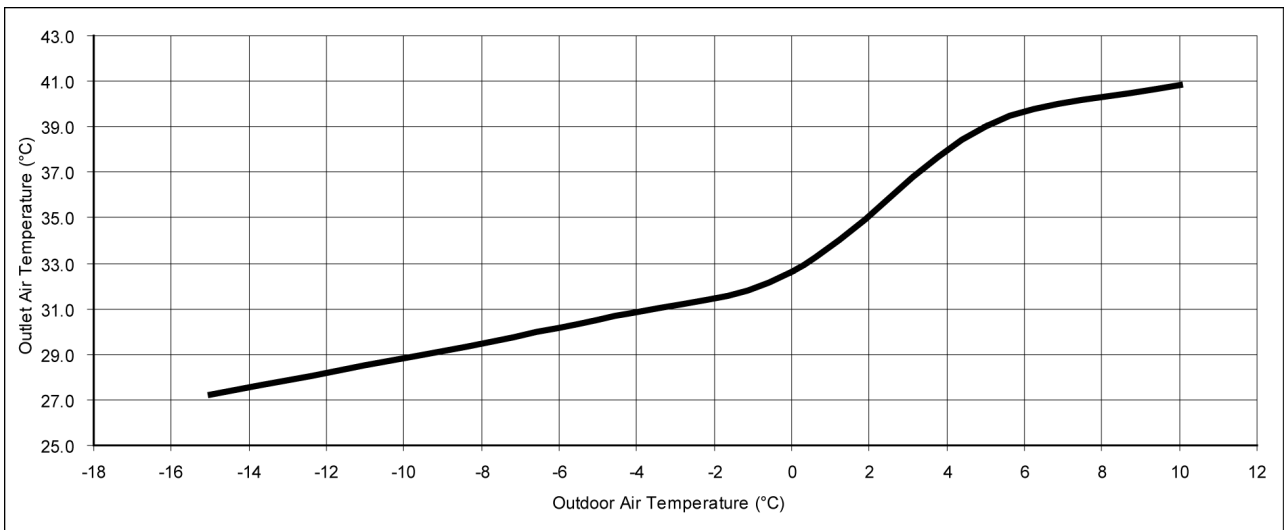
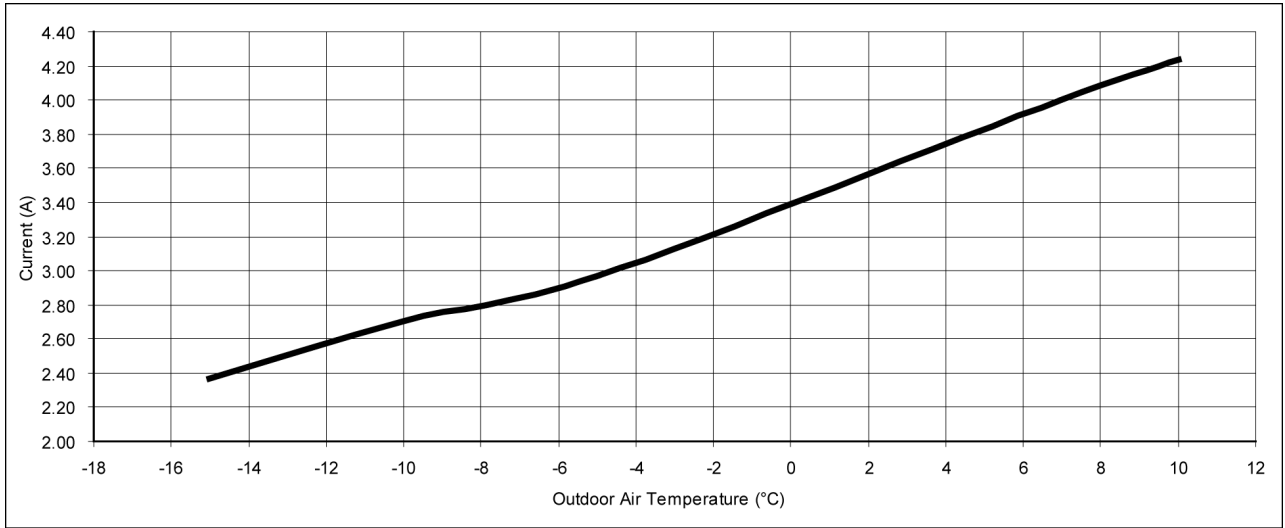

### Cooling Characteristic at Different Piping Length

**Condition**

Indoor room temperature: 27/19 °C

Remote control setting: HI fan, COOL 16 °C

Compressor frequency: rated cooling

Voltage: 230 V

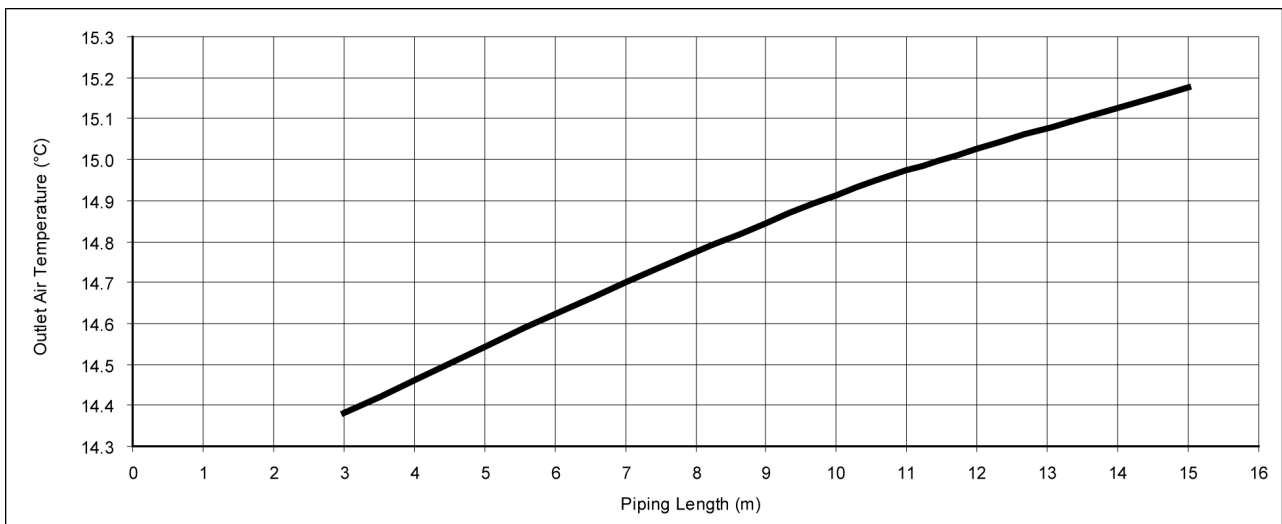
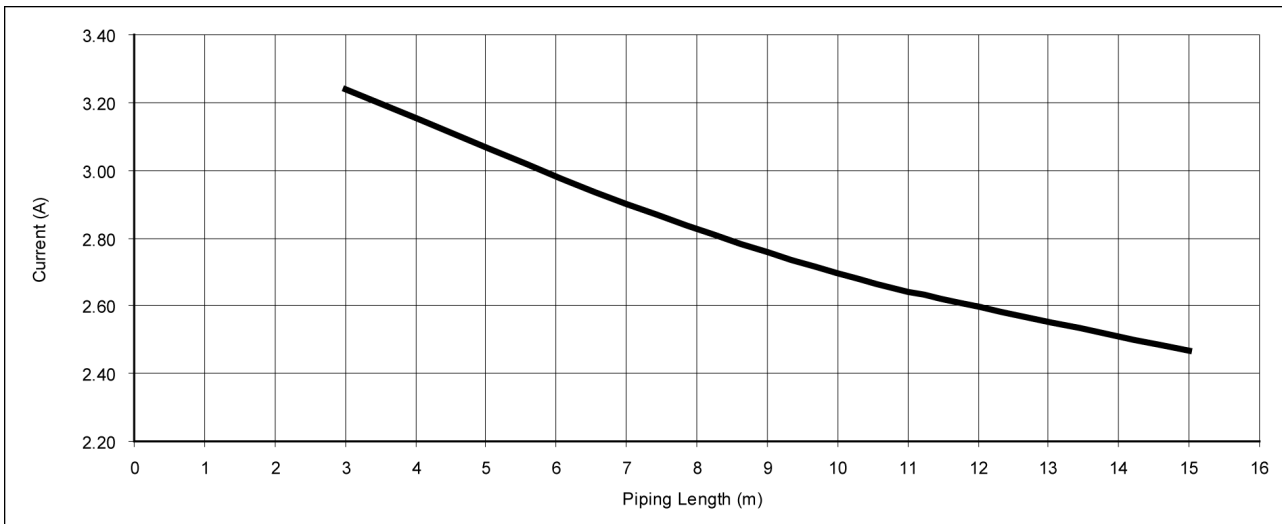
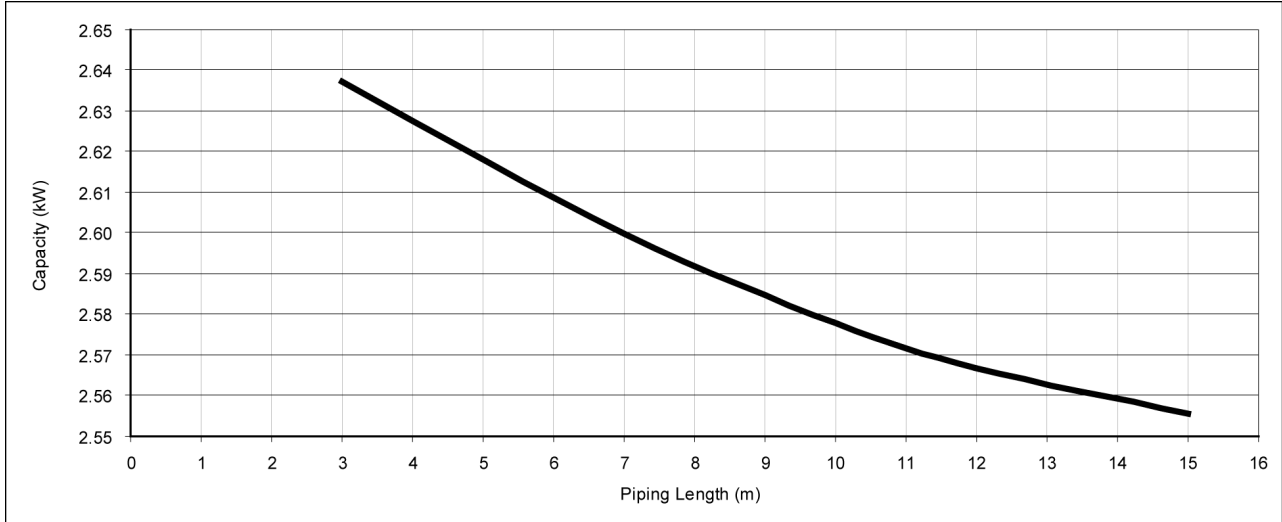



### Heating Characteristic at Different Piping Length

#### Condition

Indoor room temperature: 20 °C

Remote control setting: HI fan, HEAT 30 °C

Compressor frequency: rated heating

Voltage: 230 V

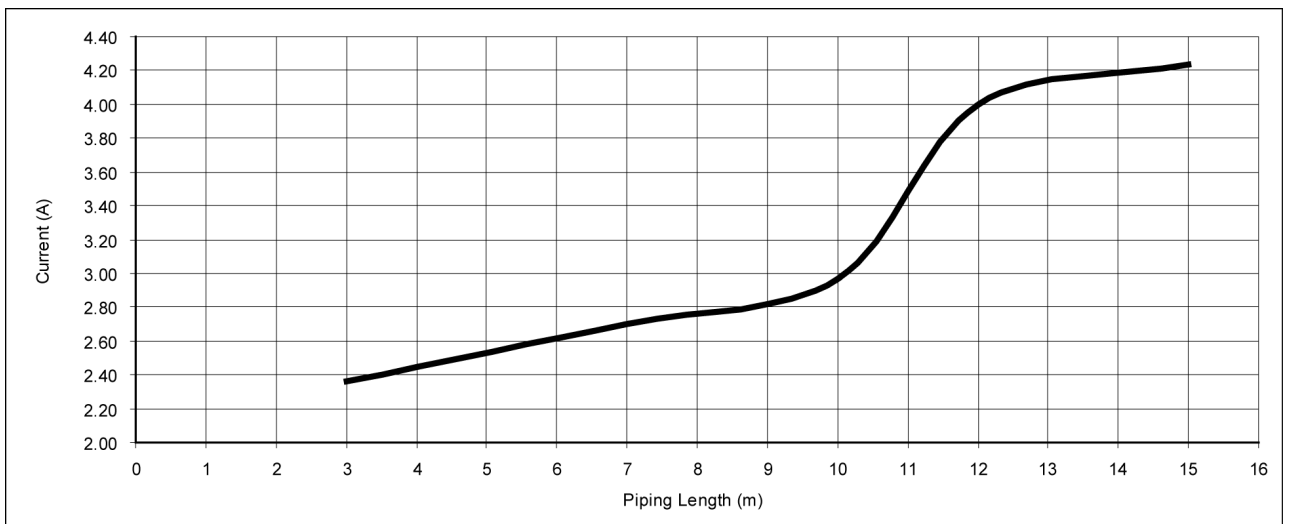
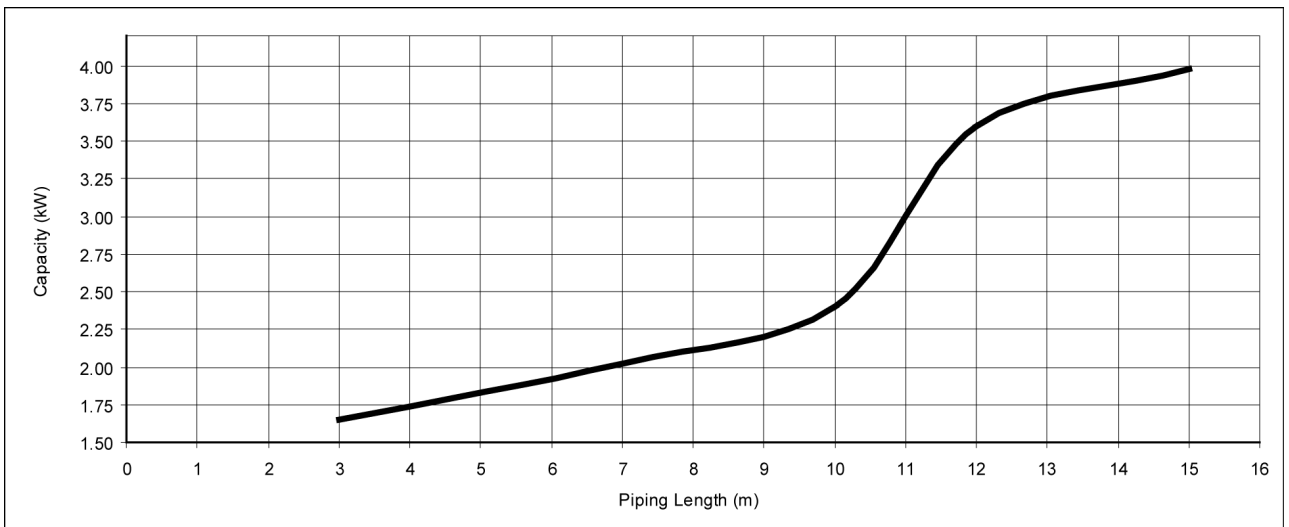

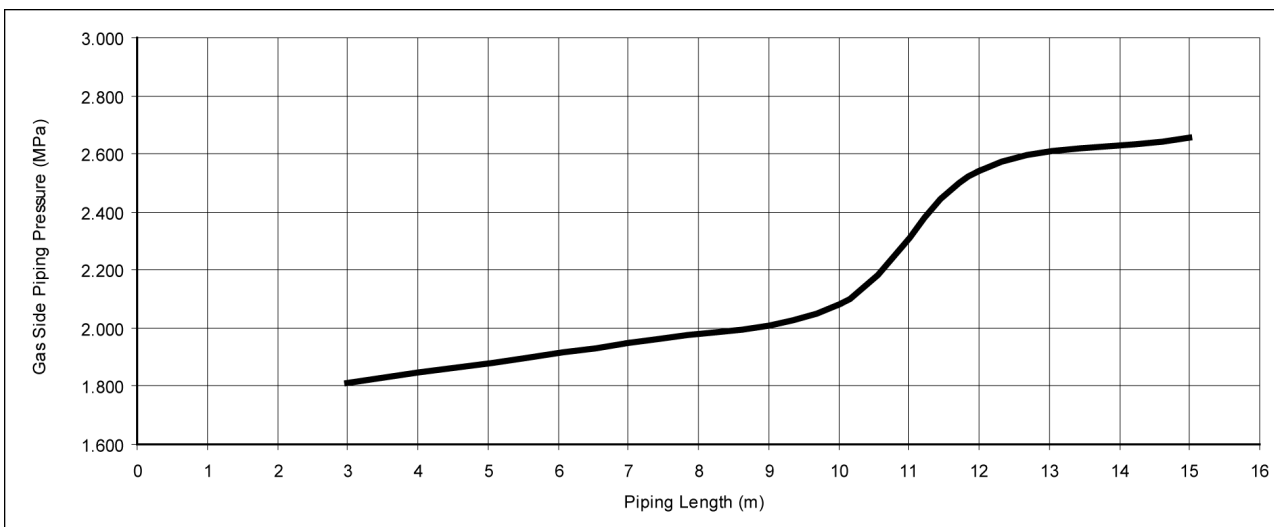
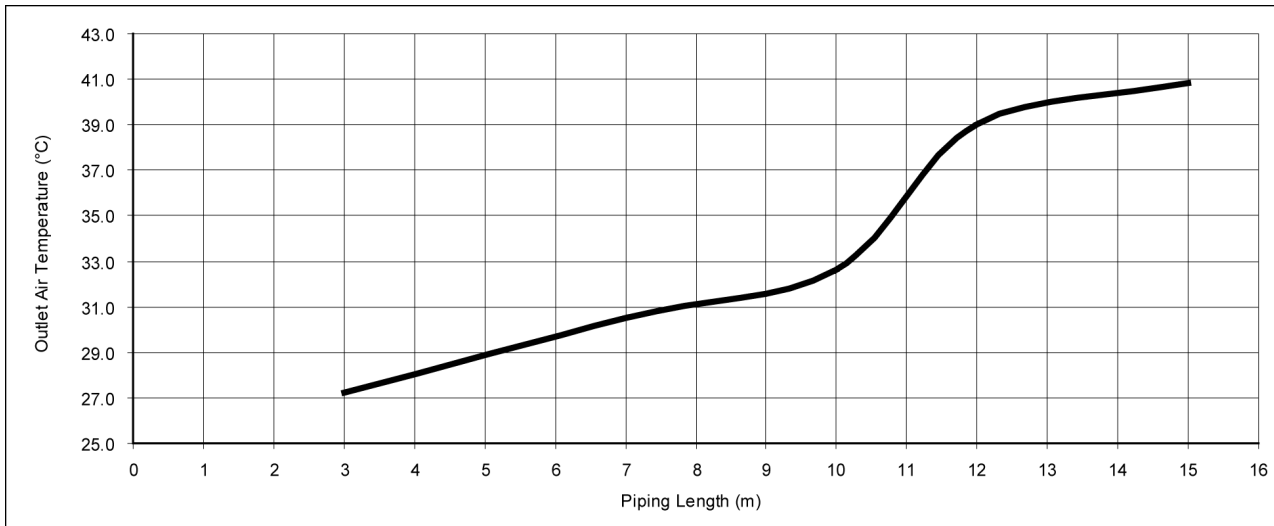



## 16.2. CS-E12EKEB CU-E12EKEB

### Cooling Characteristic at Different Outdoor Air Temperature

#### Condition

Indoor room temperature: 27/19 °C

Remote control setting: HI fan, COOL 16 °C

Compressor frequency: rated cooling

Voltage: 230 V

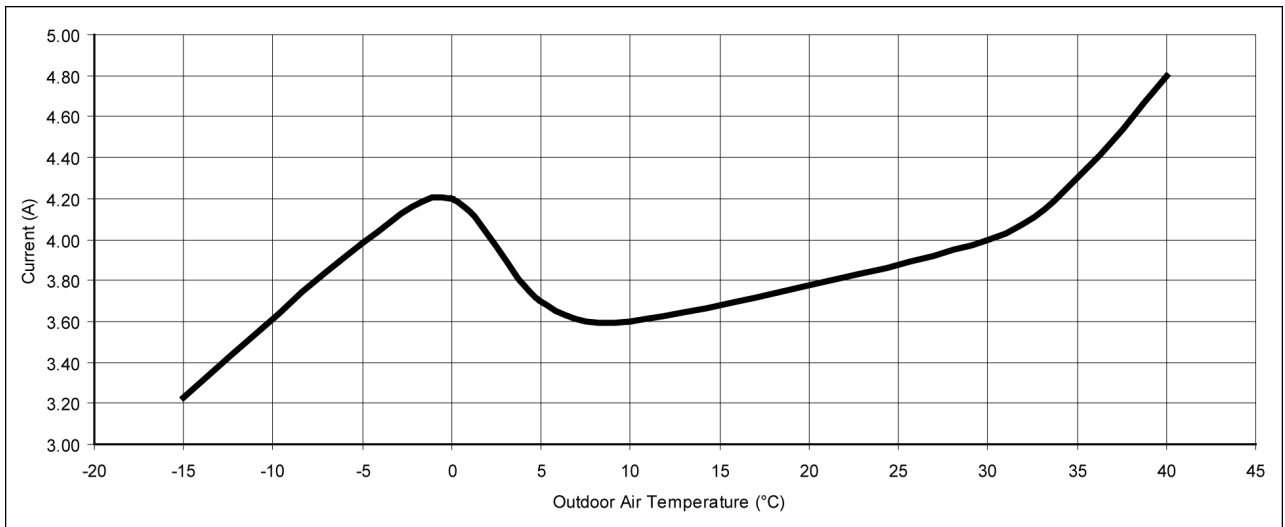
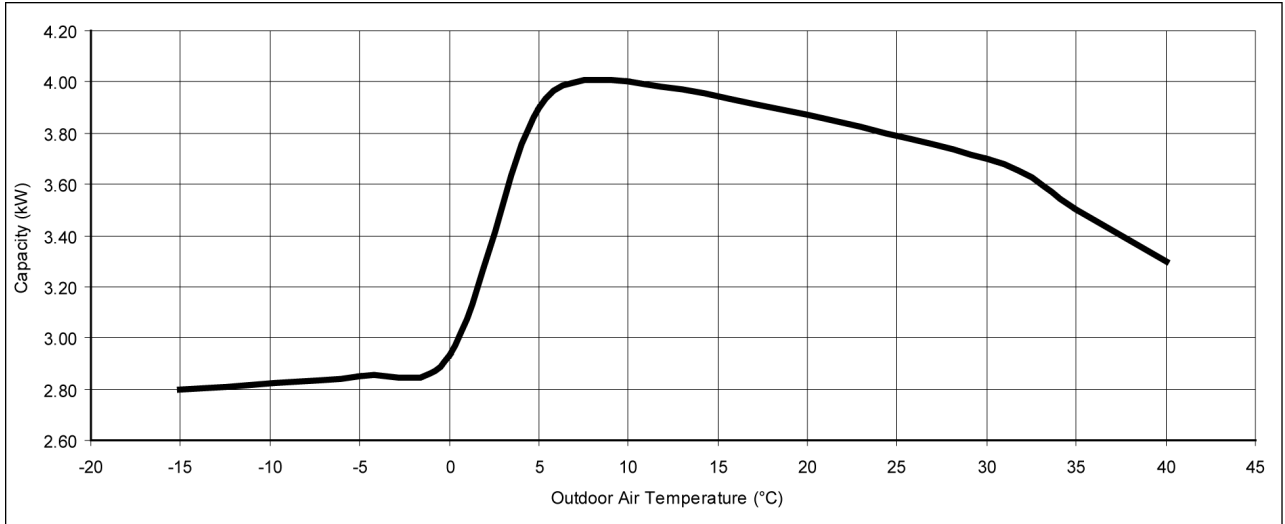

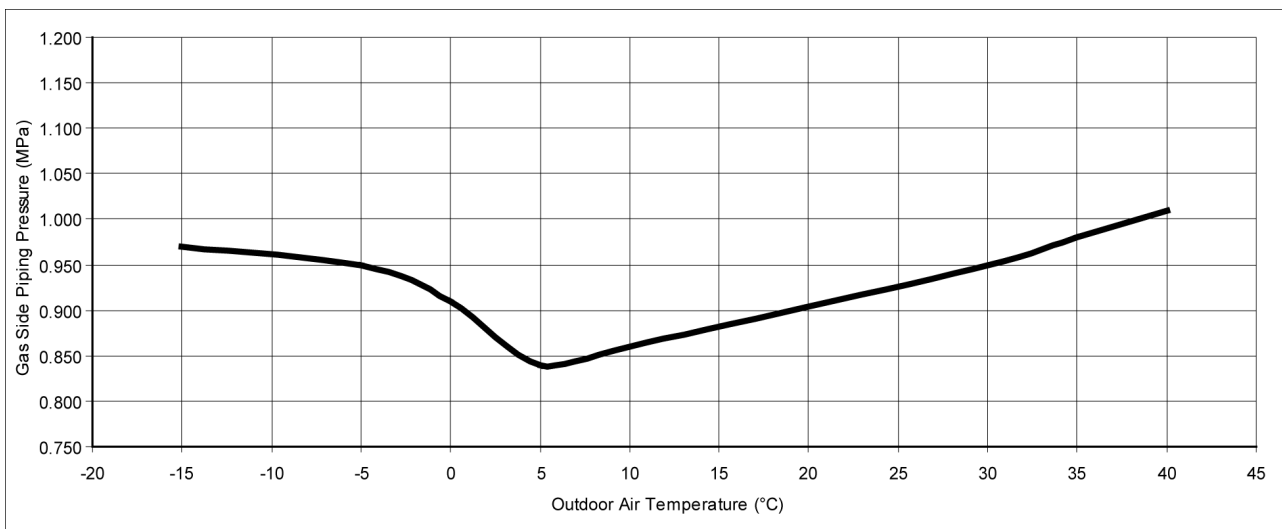
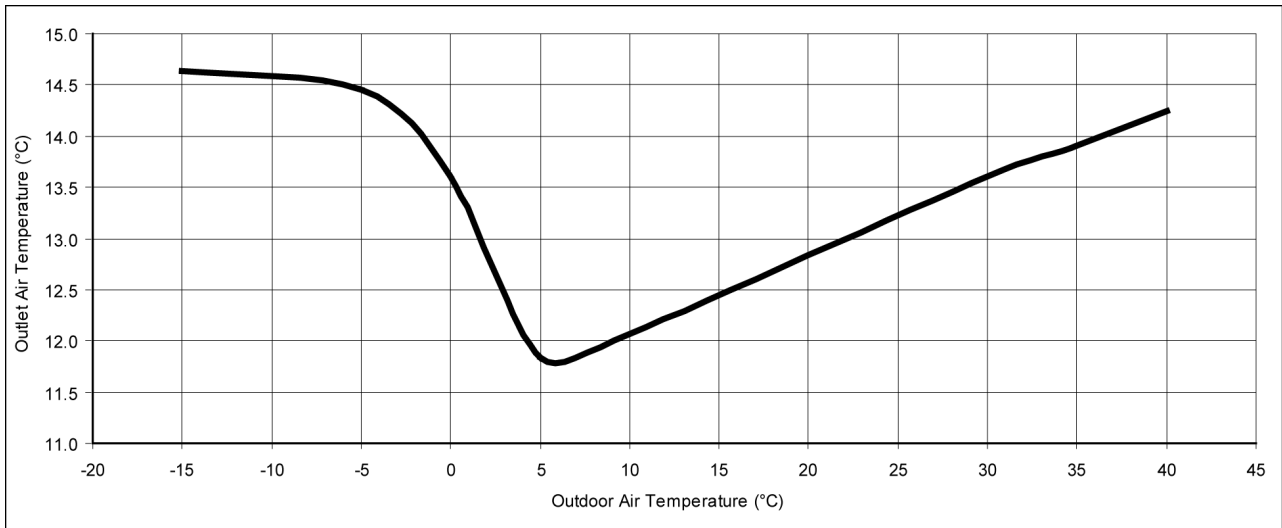

### Heating Characteristic at Different Outdoor Air Temperature

**Condition**

Indoor room temperature: 20 °C

Remote control setting: HI fan, HEAT 30 °C

Compressor frequency: rated heating

Voltage: 230 V

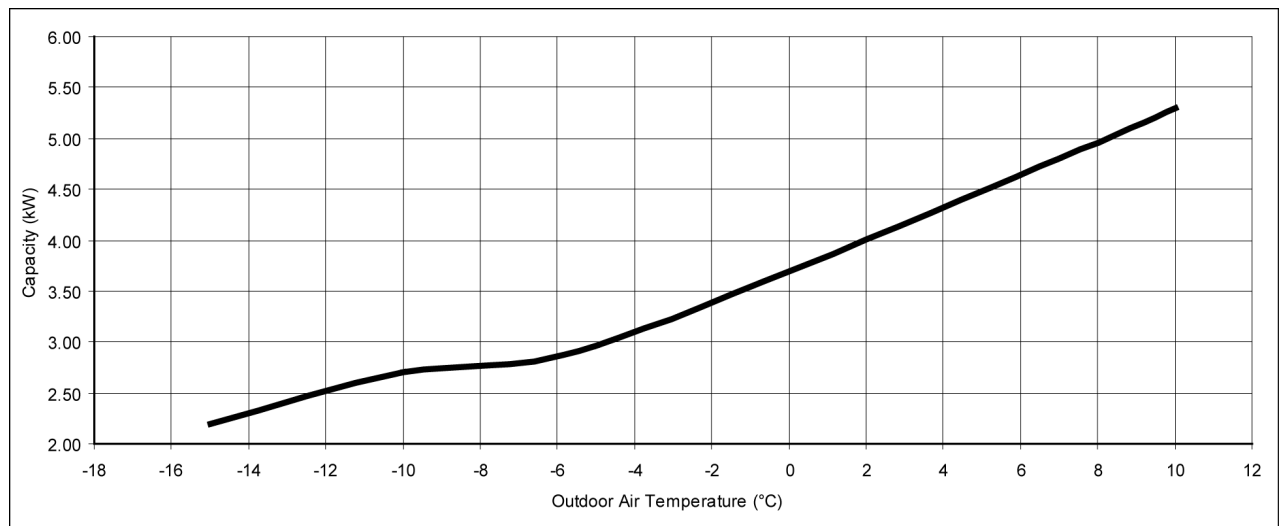

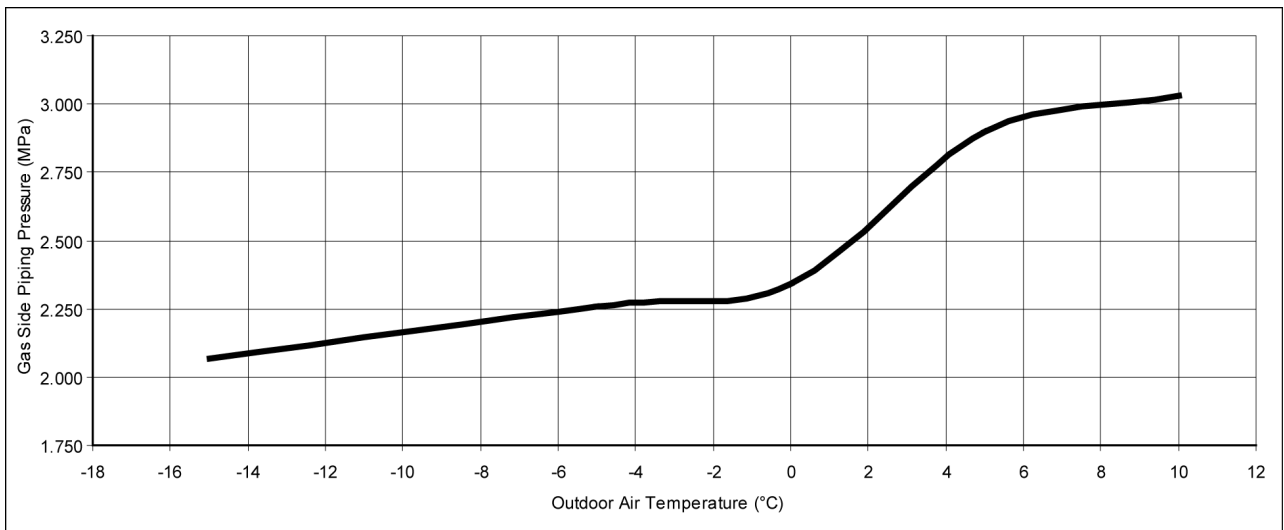
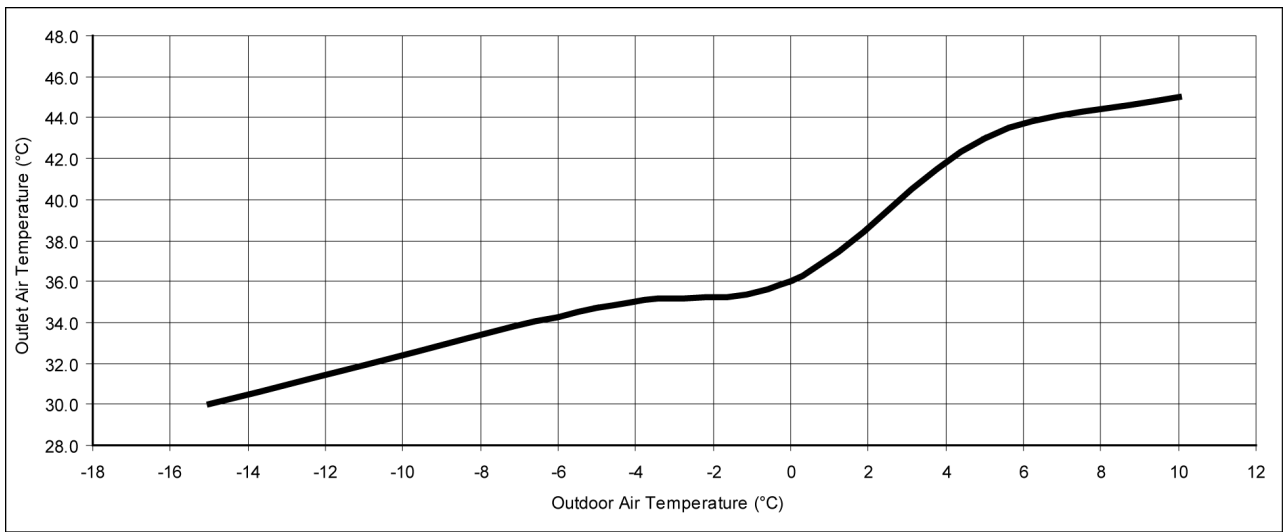
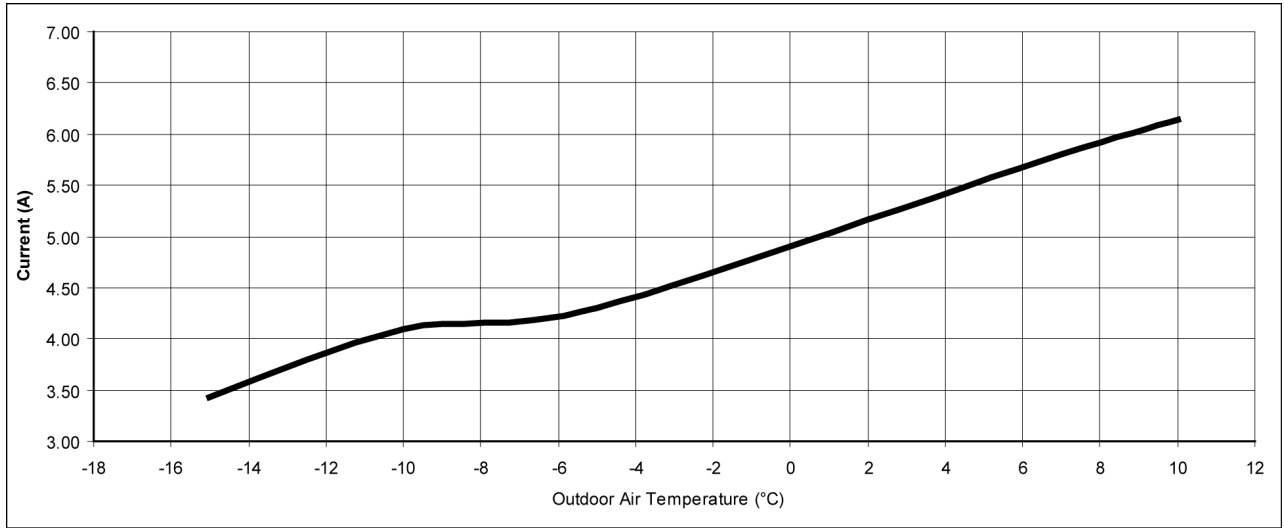

### Cooling Characteristic at Different Piping Length

**Condition**

Indoor room temperature: 27/19 °C

Remote control setting: HI fan, COOL 16 °C

Compressor frequency: rated cooling

Voltage: 230 V

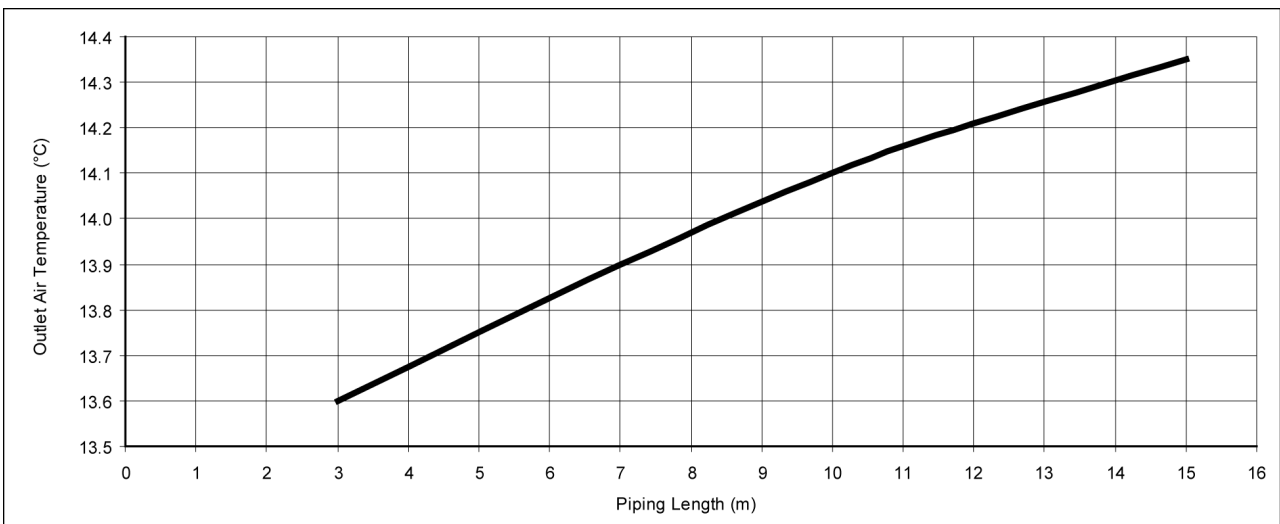
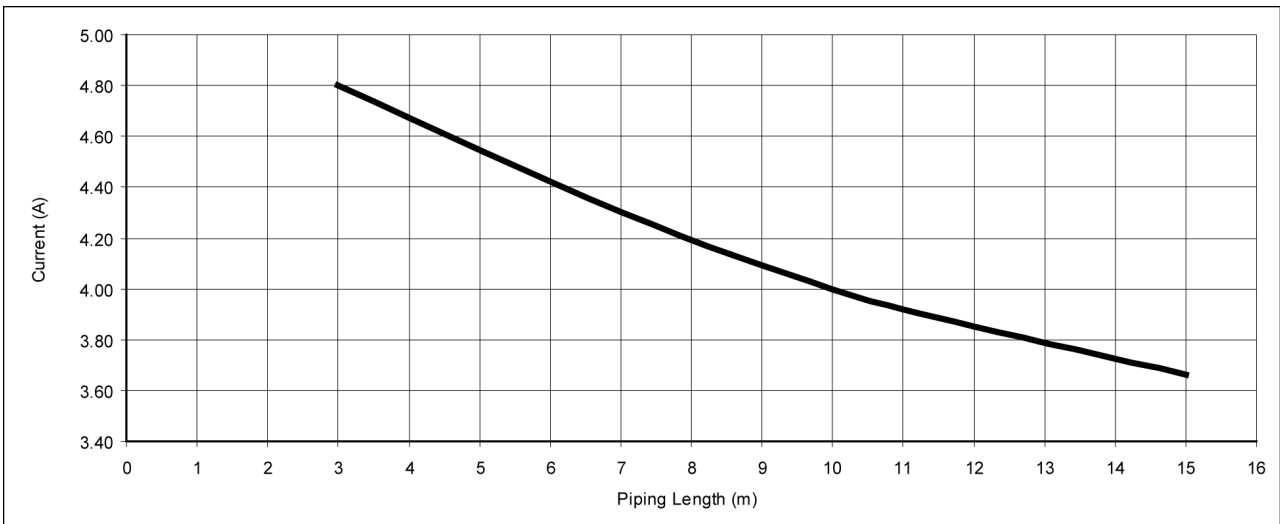
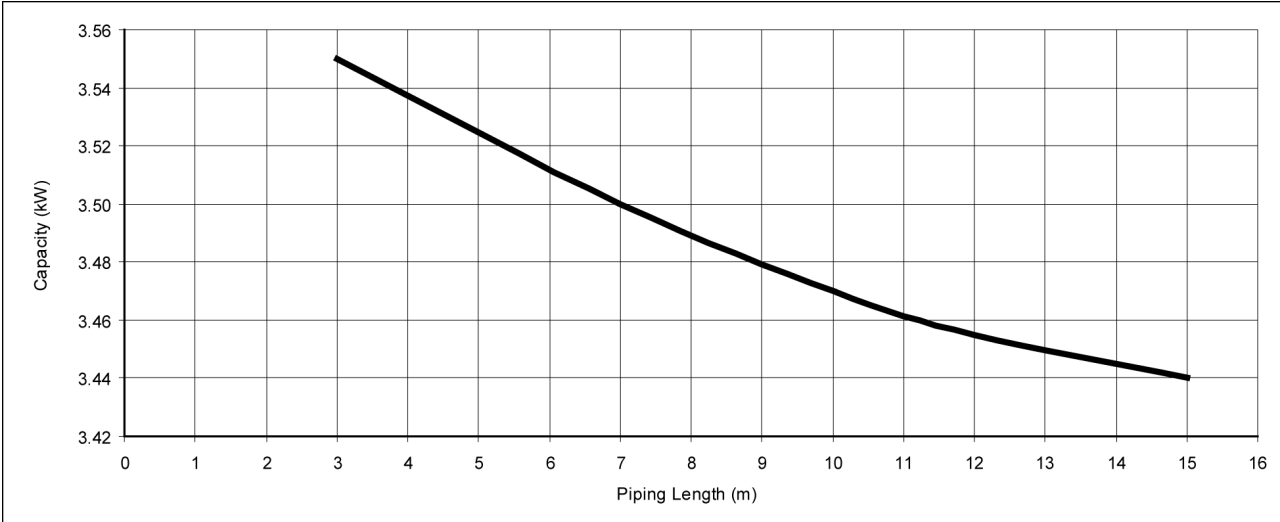

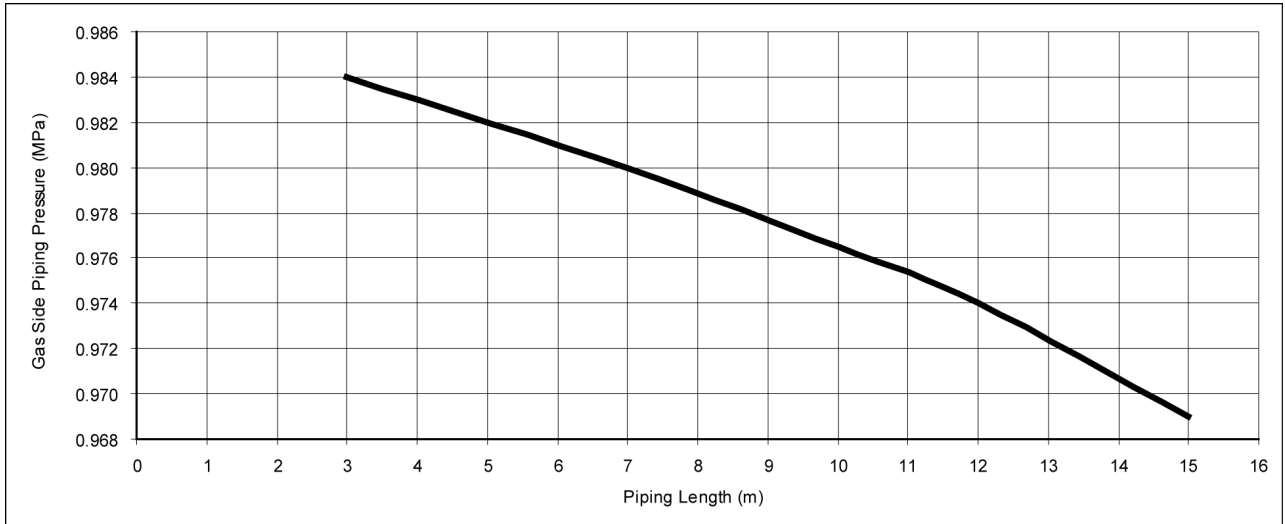

### Heating Characteristic at Different Piping Length

#### Condition

Indoor room temperature: 20 °C

Remote control setting: HI fan, HEAT 30 °C

Compressor frequency: rated heating

Voltage: 230 V

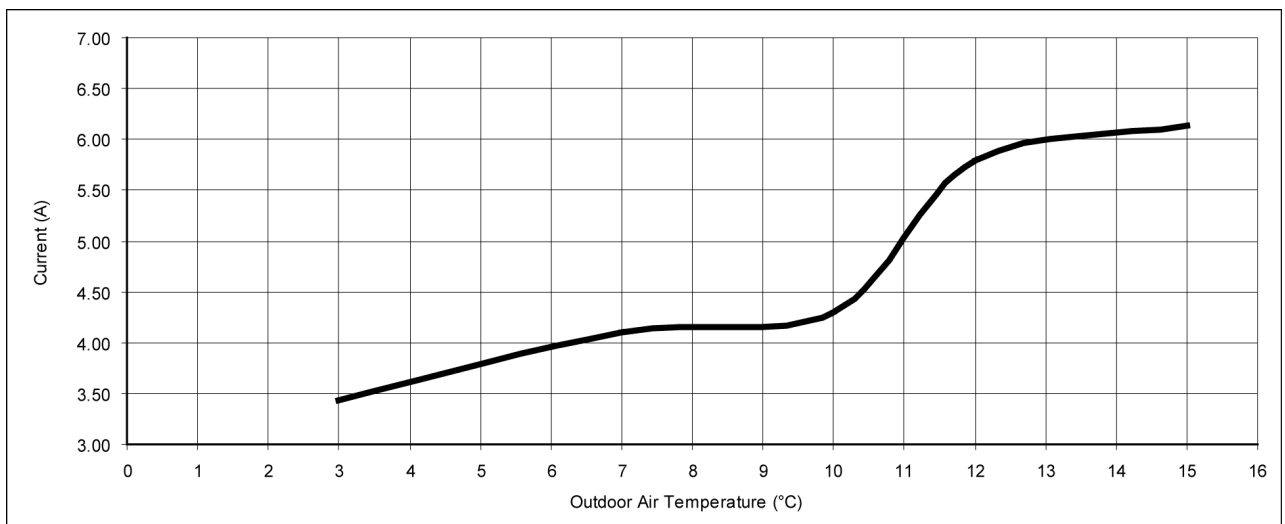
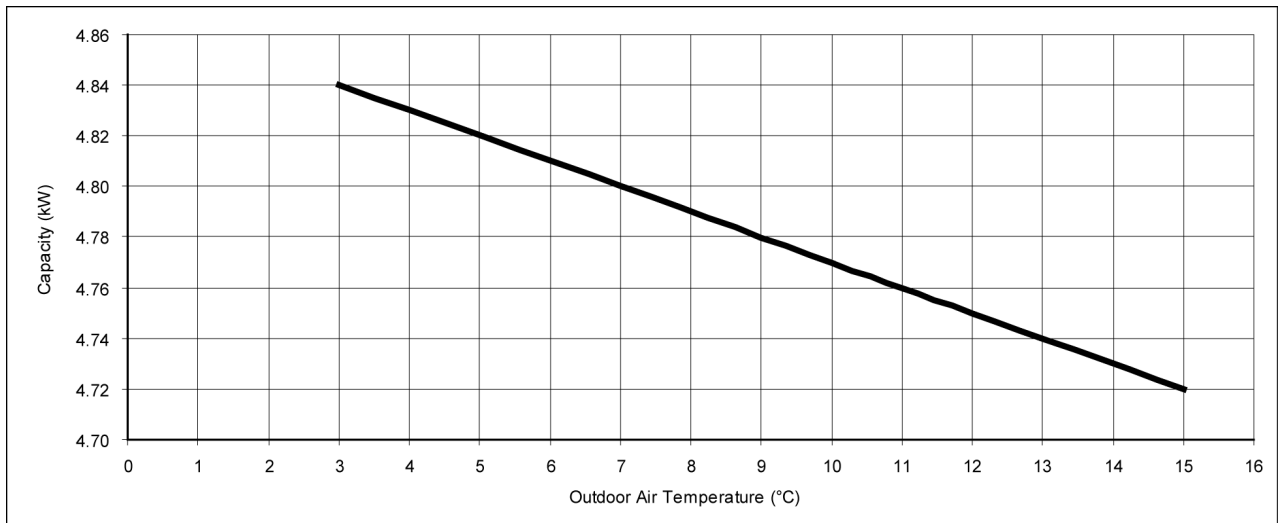

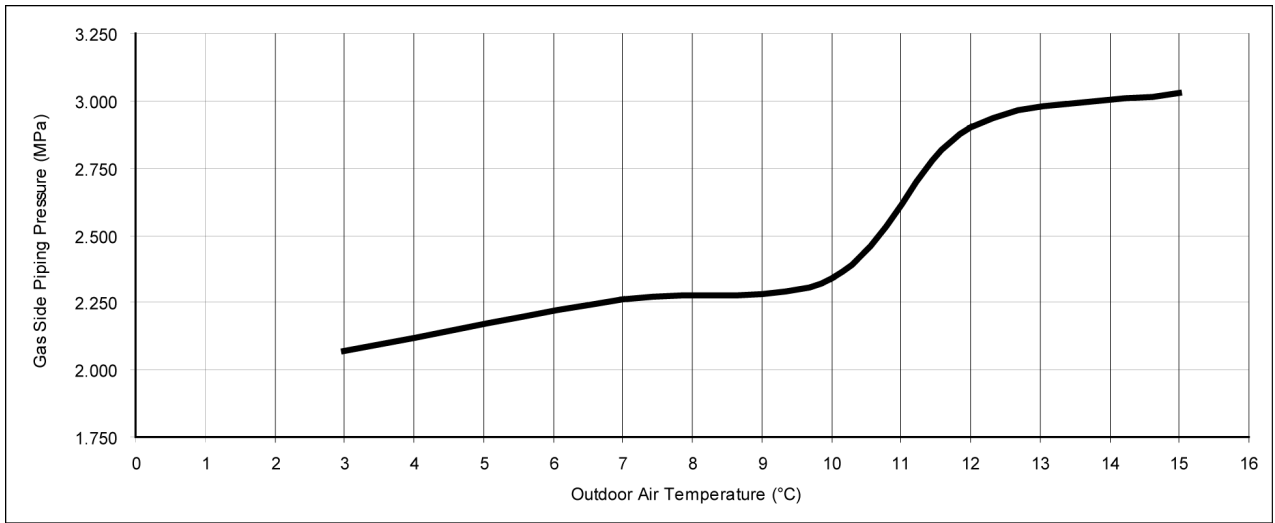
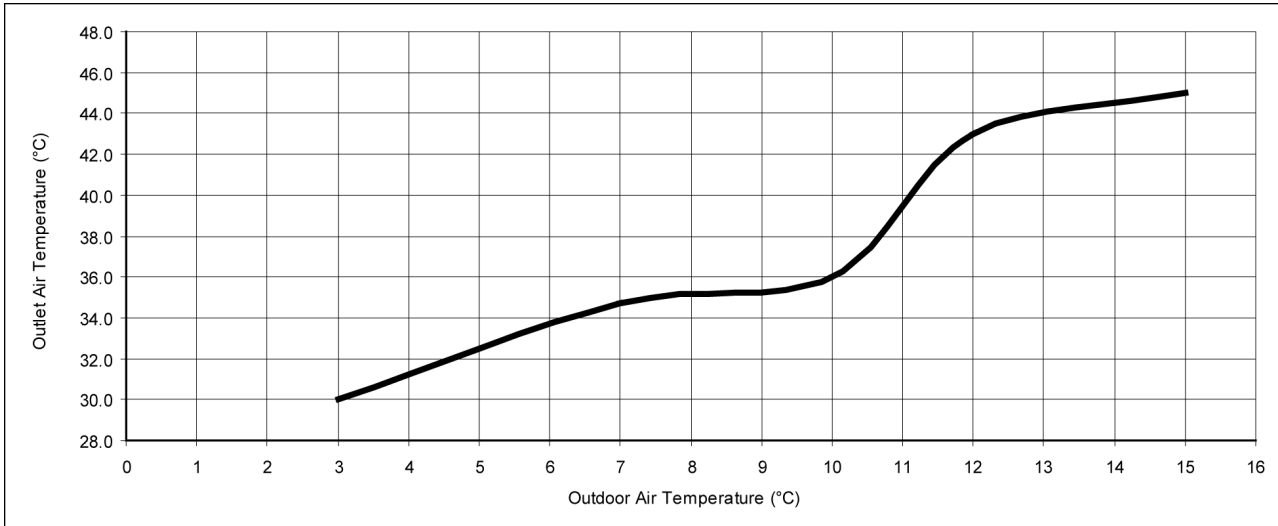

### 16.3. Sensible Capacity Chart

**Condition**

Indoor temperature : 27°C / 19°C

Outdoor temperature : 35°C / 24°C

● **CS-E9EKEB CU-E9EKEB**

230V Indoor wet bulb temperature	Outdoor Temperature (°C)											
	30			35			40			46		
	TC	SHC	IP	TC	SHC	IP	TC	SHC	IP	TC	SHC	IP
17.0°C	2.58	1.96	0.54	2.41	1.88	0.58	2.24	1.80	0.62	2.04	1.71	0.67
19.0°C				2.60		0.59						
19.5°C	2.83	2.05	0.55	2.65	1.97	0.59	2.46	1.89	0.63	2.24	1.80	0.68
22.0°C	3.09	2.12	0.56	2.88	2.04	0.60	2.68	1.97	0.64	2.44	1.88	0.70

● **CS-E12EKEB CU-E12EKEB**

230V Indoor wet bulb temperature	Outdoor Temperature (°C)											
	30			35			40			46		
	TC	SHC	IP	TC	SHC	IP	TC	SHC	IP	TC	SHC	IP
17.0°C	3.47	2.63	0.84	3.24	2.52	0.91	3.02	2.43	0.97	2.74	2.30	1.05
19.0°C				3.50		0.92						
19.5°C	3.81	2.76	0.86	3.56	2.65	0.92	3.31	2.55	0.99	3.01	2.43	1.07
22.0°C	4.15	2.86	0.87	3.88	2.75	0.94	3.61	2.65	1.01	3.28	2.53	1.08

TC - Total Cooling Capacity (kW)

SHC - Sensible Heat Capacity (kW)

IP - Input Power (kW)

# 17 Exploded View And Replacement Parts List

## 17.1. CS-E9EKEB CS-E12EKEB

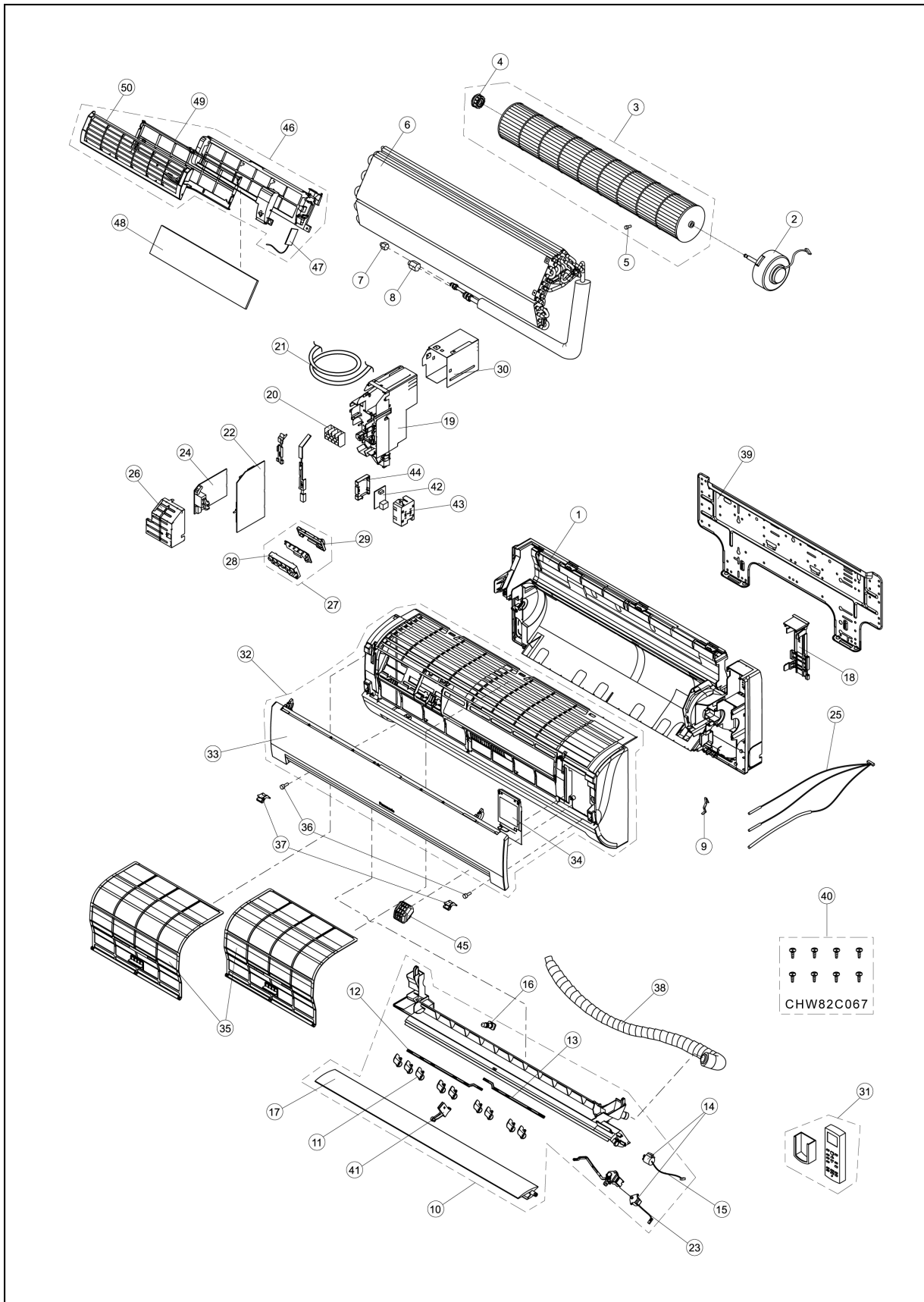

**Note:**

The above exploded view is for the purpose of parts disassembly and replacement.  
 The non-numbered parts are not kept as standard service parts.

## 17.2. CS-E9EKEB CS-E12EKEB

REF. NO.	PART NAME & DESCRIPTION	QTY.	CS-E9EKEB	CS-E12EKEB	Remarks
1	CHASSY COMPLETE	1	CWD50C1431	←	
2	FAN MOTOR, DC 30W 3PH	1	CWA981149J	←	O
3	CROSS FLOW FAN COMPLETE	1	CWH02C1045	←	
4	BEARING ASSY	1	CWH64K007	←	
5	SCREW - CROSS FLOW FAN	1	CWH551146	←	
6	EVAPORATOR CO.	1	CWB30C1832	CWB30C1833	
7	FLARE NUT (1/4)	1	CWT251030	←	
8	FLARE NUT (3/8) (1/2)	1	CWT251031	CWT251032	
9	CLIP FOR SENSOR	1	CWH32143	←	
10	DISCHARGE GRILLE COMPLETE	1	CWE20C2343	←	
11	VERTICAL VANE	9	CWE241150	←	
12	CONNECTING BAR	1	CWE261072	←	
13	CONNECTING BAR	1	CWE261065	←	
14	A.S.MOTOR, DC SINGLE 12V 300Ω	2	CWA98260+MJ	←	O
15	LEADWIRE - AIR SWING MOTOR	1	CWA67C3849	←	
16	CAP - DRAIN TRAY	1	CWH521096	←	
17	HORIZONTAL VANE	1	CWE241173	←	
18	BACK COVER CHASSIS	1	CWD932454	←	
19	CONTROL BOARD CASING	1	CWH102289	←	
20	TERMINAL BOARD COMPLETE	1	CWA28C2069	←	O
21	P.S CORD WITHOUT PLUG	1	CWA20C2478	←	
22	ELECTRONIC CONTROLLER - MAIN	1	CWA73C2014	CWA73C2015	O
23	LEAD WIRE - AIR SWING MOTOR	1	CWA67C3977	←	O
24	ELECTRONIC CONTROLLER - POWER	1	CWA744060	←	
25	SENSOR COMPLETE	1	CWA50C2321	←	O
26	CONTROL BOARD FRONT COVER CO.	1	CWH13C1120	←	
27	INDICATOR COMPLETE	1	CWE39C1126	←	O
28	INDICATOR HOLDER	1	CWD932429	←	
29	INDICATOR HOLDER	1	CWD932430	←	
30	CONTROL BOARD TOP COVER	1	CWH131207	←	
31	REMOTE CONTROL COMPLETE	1	CWA75C2807	←	O
32	FRONT GRILLE CO.	1	CWE11C3138	←	O
33	INTAKE GRILLE COMPLETE	1	CWE22C1154	←	
34	GRILLE DOOR	1	CWE141073	←	
35	AIR FILTER	2	CWD001144	←	
36	SCREW - FRONT GRILLE	2	XTT4+16CFJ	←	
37	CAP - FRONT GRILLE	2	CWH521109	←	
38	DRAIN HOSE	1	CWH851063	←	
39	INSTALLATION PLATE	1	CWH361067	←	
40	BAG COMP. - INSTALLATION SCREW	1	CWH82C067	←	
41	FULCRUM	1	CWH621046	←	
42	ELECTRONIC CONTROLLER - IONIZER	1	CWA743675	←	O
43	CASING - IONIZER	1	CWD932464	←	
44	CASING - IONIZER	1	CWD932431	←	
45	ION GENERATOR	1	CWH94C0001	←	
46	SUPERSONIC AIR PURIFYING DEVICE	1	CWH91C1013	←	
47	ELEC. CONTROLLER - SUPERSONIC	1	CWA743874	←	O
48	SUPER ALLERU BUSTER FILTER	1	CWD00C1133	←	
49	FRAME FR AIR FILTER SUPERSONIC	1	CWD011026	←	
50	FRAME FR AIR FILTER SUPERSONIC	1	CWD011027	←	

(Note)

- All parts are supplied from PHAAM, Malaysia (Vendor Code: 061).
- "O" marked parts are recommended to be kept in stock.

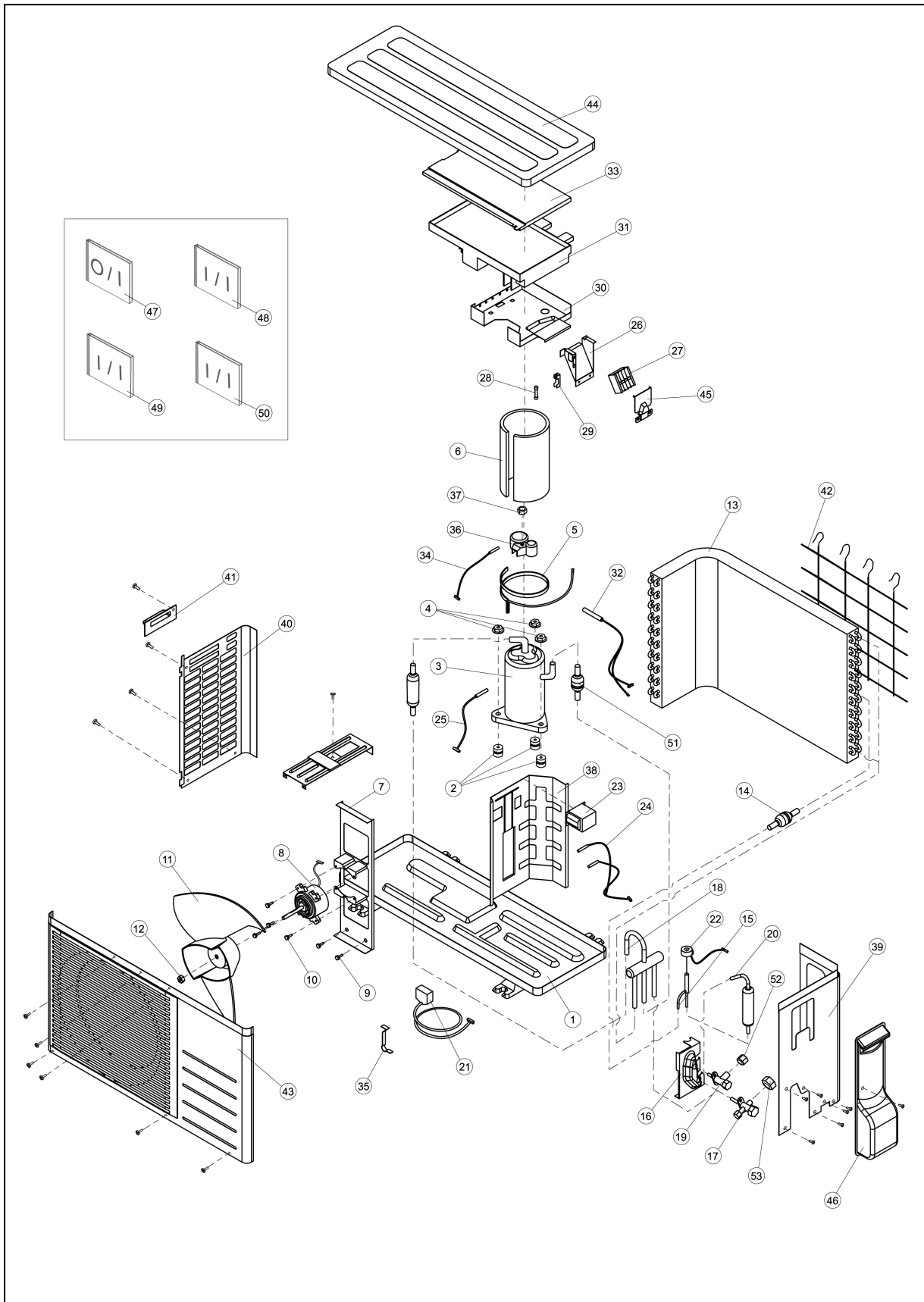

## 17.3. CU-E9EKEB CU-E12EKEB

**Note:**

The above exploded view is for the purpose of parts disassembly and replacement.

The non-numbered parts are not kept as standard service parts.

## 17.4. CU-E9EKEB CU-E12EKEB

REF NO.	DESCRIPTION & NAME	QTY.	CU-E9EKEB	CU-E12EKEB	Remarks
1	CHASSY ASSY	1	CWD50K2140	←	
2	ANTI - VIBRATION BUSHING	3	CWH50077	←	
3	COMPRESSOR, DC 220V	1	5CS110XBD04	←	O
4	NUT - COMPRESSOR MOUNT	3	CWH56000J	←	
5	CRANKCASE HEATER	1	CWA341026	←	
6	SOUND PROOF MATERIAL	1	CWVG300001	←	
7	FAN MOTOR BRACKET	1	CWD541021	←	
8	FAN MOTOR, DC 40W 3PH	1	ARW44W8P40AC	←	O
9	SCREW - BRACKET FAN MOTOR	2	CWH551060J	←	
10	SCREW - FAN MOTOR MOUNT	4	CWH55252J	←	
11	PROPELLER FAN ASSY	1	CWH03K1013	←	
12	NUT - PROPELLER FAN	1	CWH56053J	←	
13	CONDENSER CO.	1	CWB32C1741	←	
14	STRAINER	1	CWB11094	←	
15	TUBE ASSY CO. (EXP. VALVE)	1	CWT01C3643-1	←	
16	HOLDER-COUPLING	1	CWH351025	←	
17	3-WAY VALVE	1	CWB011165J	CWB011316J	O
18	4-WAY VALVE	1	CWB001037J	←	O
19	2-WAY VALVE	1	CWB021180J	←	O
20	DRYER	1	CWB101016J	←	O
21	V-COIL CO. FOR 4-WAY VALVE	1	CWA43C2144J	←	O
22	V-COIL COMPLETE FOR EXP. VALVE	1	CWA43C2058J	←	
23	REACTOR	1	CWA421050	CWA421085	
24	SENSOR COMPLETE	1	CWA50C2241	←	
25	SENSOR COMPLETE	1	CWA50C2281	←	
26	CONTROL BOARD CASING	1	CWH102294	←	
27	TERMINAL BOARD ASSY	1	CWA28K1021J	←	
28	FUSE, 250V	1	XBA2C31TR0	←	
29	FUSE HOLDERS	1	K3GB1BH00005	←	
30	CONTROL BOARD CASING	1	CWH102293	←	
31	ELECTRONIC CONTROLLER - MAIN	1	CWA73C1996R	CWA73C1997R	O
32	OVER HEAT PROTECTOR COMPLETE	1	CWA14C1011	←	
33	CONTROL BOARD COVER	1	CWH131264	←	
34	SENSOR - COMPLETE	1	CWA50C2066	←	
35	CLIP FOR SENSOR	1	CWH321010	←	
36	TERMINAL COVER	1	CWH171001	←	
37	NUT FOR TERMINAL COVER	1	CWH7080300J	←	
38	SOUND PROOF BOARD	1	CWH151090	←	
39	CABINET SIDE PLATE	1	CWE041074A	←	
40	CABINET SIDE PLATE (LEFT)	1	CWE041144A	←	
41	HANDLE	1	CWE161010	←	
42	WIRE NET	1	CWD041054A	←	
43	CABINET FRONT PLATE CO.	1	CWE06C1136	←	
44	CABINET TOP PLATE	1	CWE031014A	←	
45	CONTROL BOARD COVER	1	CWH131213	←	
46	CONTROL BOARD COVER COMPLETE	1	CWH13C1145	←	
47	OPERATING INSTRUCTION	1	CWF565072	←	
48	INSTALLATION INSTRUCTION	1	CWF612893	←	
49	INSTALLATION INSTRUCTION	1	CWF612894	←	
50	INSTALLATION INSTRUCTION	1	CWF612895	←	
51	STRAINER	1	CWB111004	←	
52	FLARE NUT (1/4)	1	CWT251030	←	
53	FLARE NUT (3/8) (1/2)	1	CWT251031	CWT251032	

(Note)

- All parts are supplied from PHAAM Malaysia (Vendor Code: 061).
- "O" marked parts are recommended to be kept in stock.