

SPLIT TYPE  
ROOM AIR CONDITIONER  
WALL MOUNTED TYPE



# SERVICE MANUAL



Indoor unit	Outdoor unit
ASYG14LMCE	AOYG14LMCE

## CONTENTS

SPECIFICATIONS.....	1
DIMENSIONS.....	2
REFRIGERANT SYSTEM DIAGRAM.....	4
CIRCUIT DIAGRAM.....	5
PCB CIRCUIT DIAGRAM.....	6
ERROR DETECTION.....	8
PARTS (INDOOR UNIT).....	10
PARTS (OUTDOOR UNIT).....	17
ACCESSORIES.....	21

# SPECIFICATIONS

## ELECTRICAL DATA

INDOOR UNIT		ASYG14LMCE
OUTDOOR UNIT		AOYG14LMCE
POWER SOURCE		230 V 50 Hz Single phase
Cooling	CAPACITY	4.00 kW
	POWER CONSUMPTION	1.135 kW
	EER	3.52 kW/kW
	RUNNING CURRENT	5.3 A
	MAXIMUM CURRENT	9.0 A
	MOISTURE REMOVAL	2.1 L/h
Heating	CAPACITY	5.00 kW
	POWER CONSUMPTION	1.365 kW
	COP	3.66 kW/kW
	RUNNING CURRENT	6.3 A
	MAXIMUM CURRENT	10.5 A

## DIMENSIONS

INDOOR UNIT	H x W x D	270 x 870 x 204 mm
OUTDOOR UNIT	H x W x D	540 x 790 x 290 mm

## WEIGHT

INDOOR UNIT	Net / Shipping	8.5 kg / 11 kg
OUTDOOR UNIT	Net / Shipping	34 kg / 37 kg

## FAN MOTOR

INDOOR UNIT'S Discrimination		MFD-12CYBL
OUTDOOR UNIT'S Discrimination		MFE-40VVL
INDOOR UNIT Cooling	High	1,360 rpm
	Medium	1,220 rpm
	Low	990 rpm
	Quiet	750 rpm
INDOOR UNIT Heating	High	1,360 rpm
	Medium	1,220 rpm
	Low	1,040 rpm
	Quiet	770 rpm
OUTDOOR UNIT Cooling		850 rpm
OUTDOOR UNIT Heating		750 rpm

## AIRFLOW

INDOOR UNIT Cooling	High	770 m <sup>3</sup> /h
	Medium	680 m <sup>3</sup> /h
	Low	530 m <sup>3</sup> /h
	Quiet	360 m <sup>3</sup> /h
INDOOR UNIT Heating	High	770 m <sup>3</sup> /h
	Medium	680 m <sup>3</sup> /h
	Low	560 m <sup>3</sup> /h
	Quiet	380 m <sup>3</sup> /h
OUTDOOR UNIT Cooling		1,940 m <sup>3</sup> /h
OUTDOOR UNIT Heating		1,700 m <sup>3</sup> /h

## NOISE LEVEL

INDOOR UNIT Cooling	High	44 dB	
	Medium	40 dB	
	Low	33 dB	
OUTDOOR UNIT Heating	High	44 dB	
	Medium	40 dB	
	Low	35 dB	
		Quiet	27 dB
OUTDOOR UNIT Cooling		50 dB	
OUTDOOR UNIT Heating		50 dB	

## COMPRESSOR AND REFRIGERANT

COMPRESSOR TYPE	Hermetic type, 4 pole, 3 phase, DC inverter motor, Rotary	
DISCRIMINATION	DA89X1C-20FZ2	
WEIGHT (with oil)	9.2 kg	
PRECHARGED REFRIGERANT	1,050 g	
REFRIGERANT TYPE	R410A	
FULL CHARGE	Pipe length 15 m	1,050 g
	20 m	1,150 g
ADDITIONAL CHARGE	20 g/m	
MAXIMUM PIPING HEIGHT	15m	

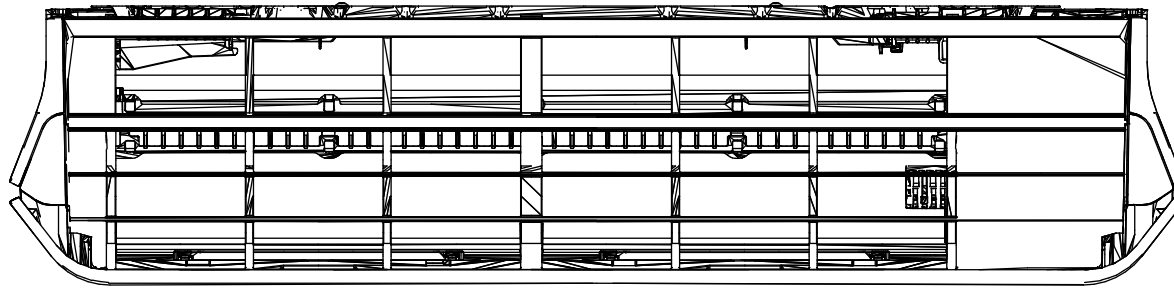

## DIMENSIONS

INDOOR UNIT

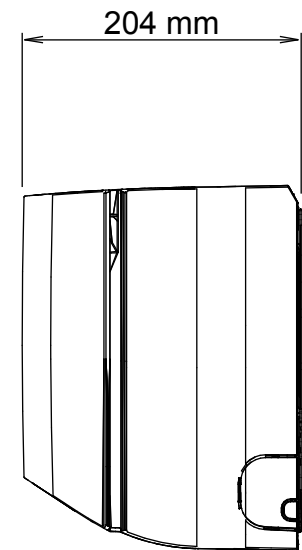
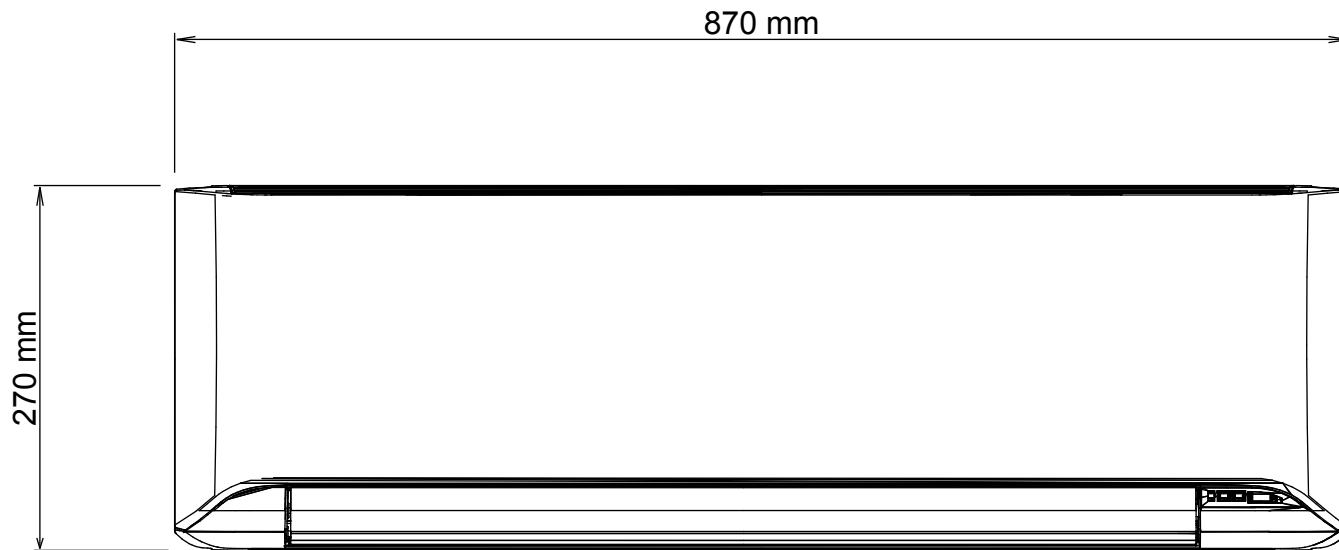

Drain hose

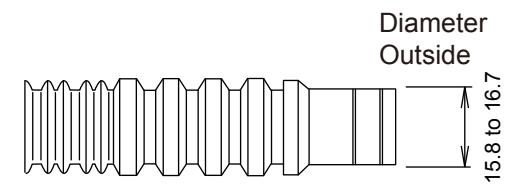
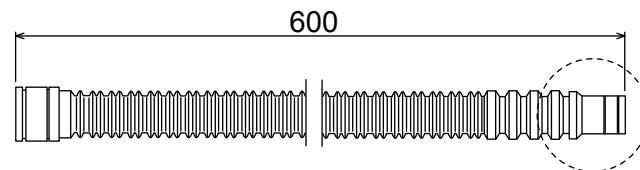

# OUTDOOR UNIT

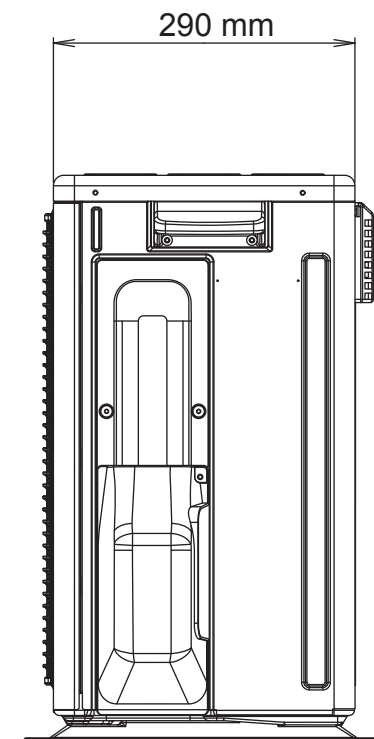
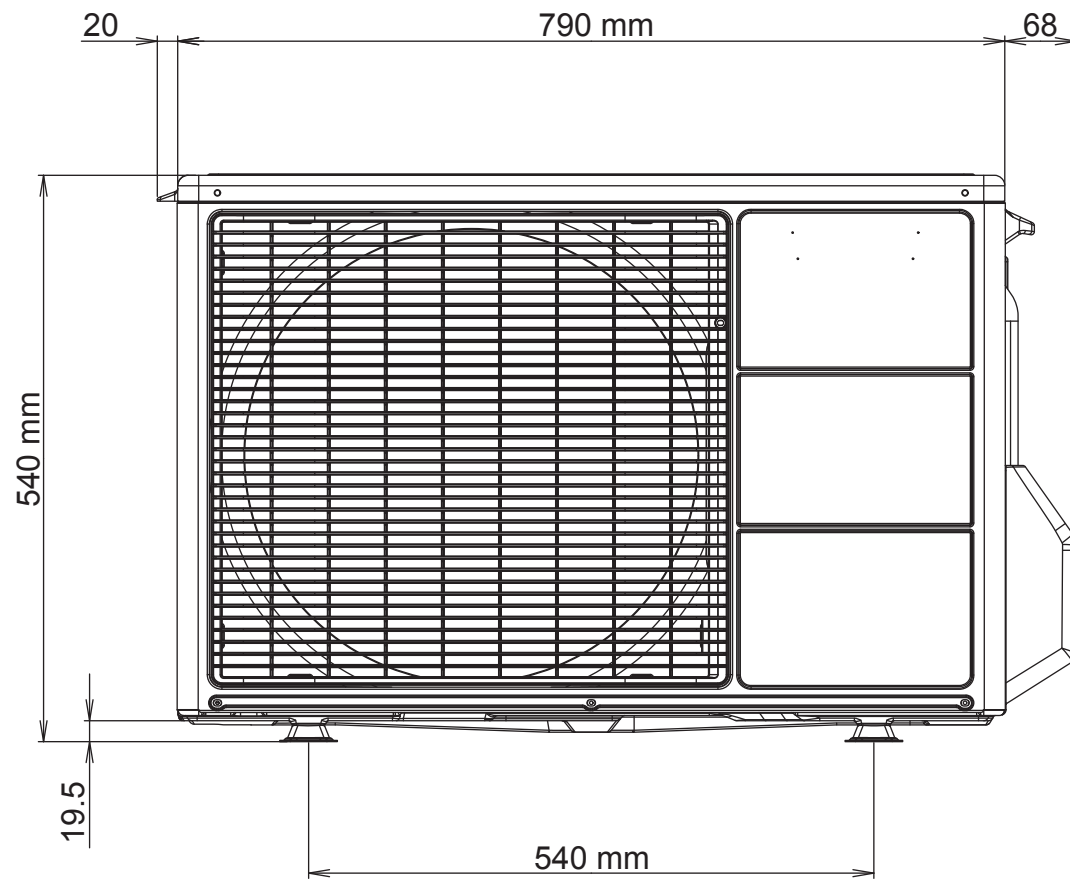

# REFRIGERANT SYSTEM DIAGRAM

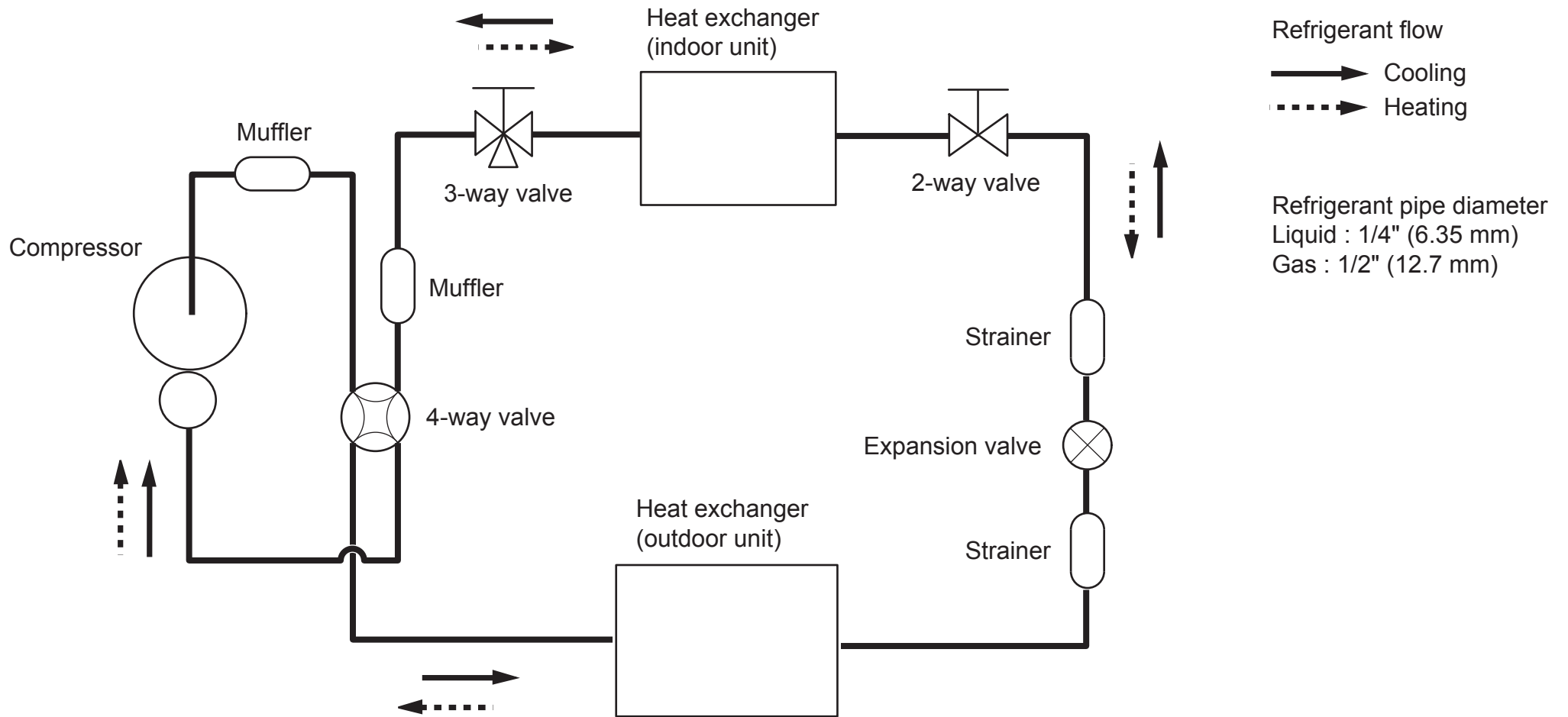

# CIRCUIT DIAGRAM

## INDOOR UNIT

## OUTDOOR UNIT

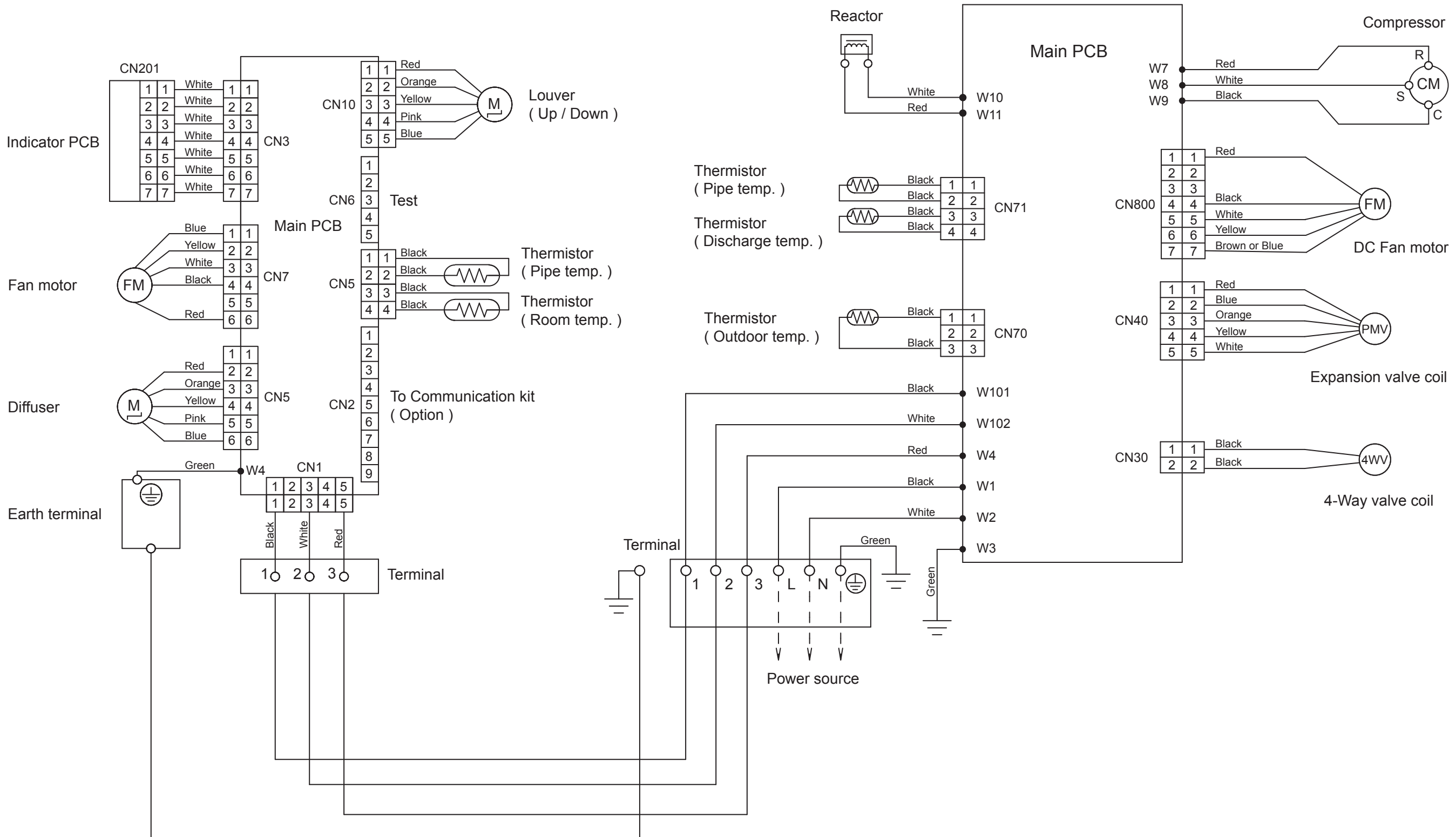

# PCB CIRCUIT DIAGRAM

CONTROL UNIT  
ASYG14LMCE : EZ-0124DHSE

CN7 DC Fan motor

Pin No.	Terminal code	Function of terminal	Lead wire color
6	Vm	Motor power voltage input	Red
5	---	---	---
4	GND	GND	Black
3	Vcc	Control power voltage input	White
2	Vsp	Speed control voltage input	Yellow
1	PG	Revolution pulse output	Blue

CN4 Thermistor Characteristics.

Thermistor	Temperature	( 0°C )	( 20°C )	( 30°C )
Thermistor ( Pipe temp. )		176.0 k Ω	62.9 k Ω	39.6 k Ω
		1.1 V	2.2 V	2.8 V
Thermistor ( Room temp. )		33.6 k Ω	12.5 k Ω	8.0 k Ω
		1.1 V	2.2 V	2.8 V

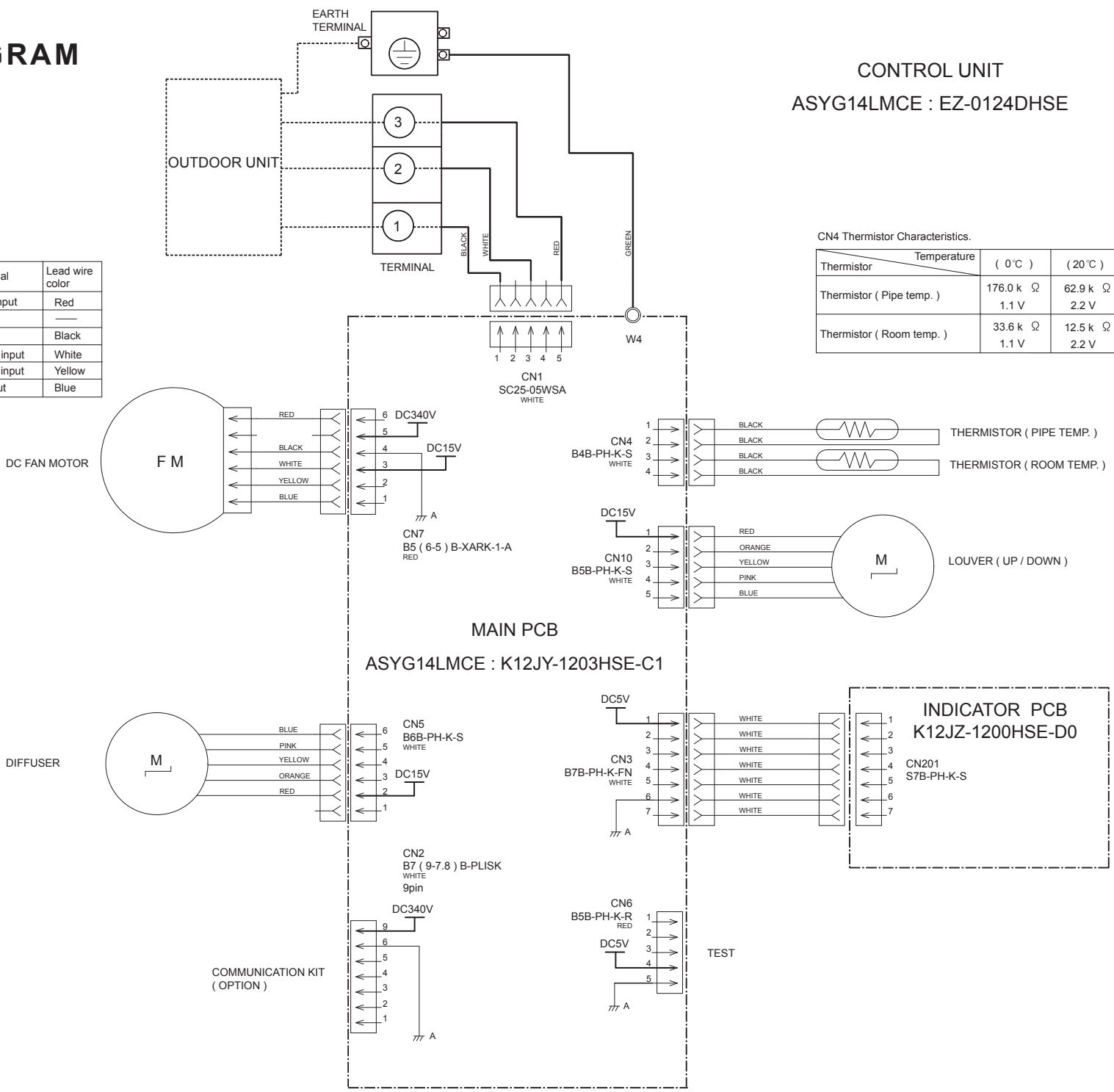

AOYG14LMCE  
INVERTER ASSEMBLY  
EZ-0122DHUE

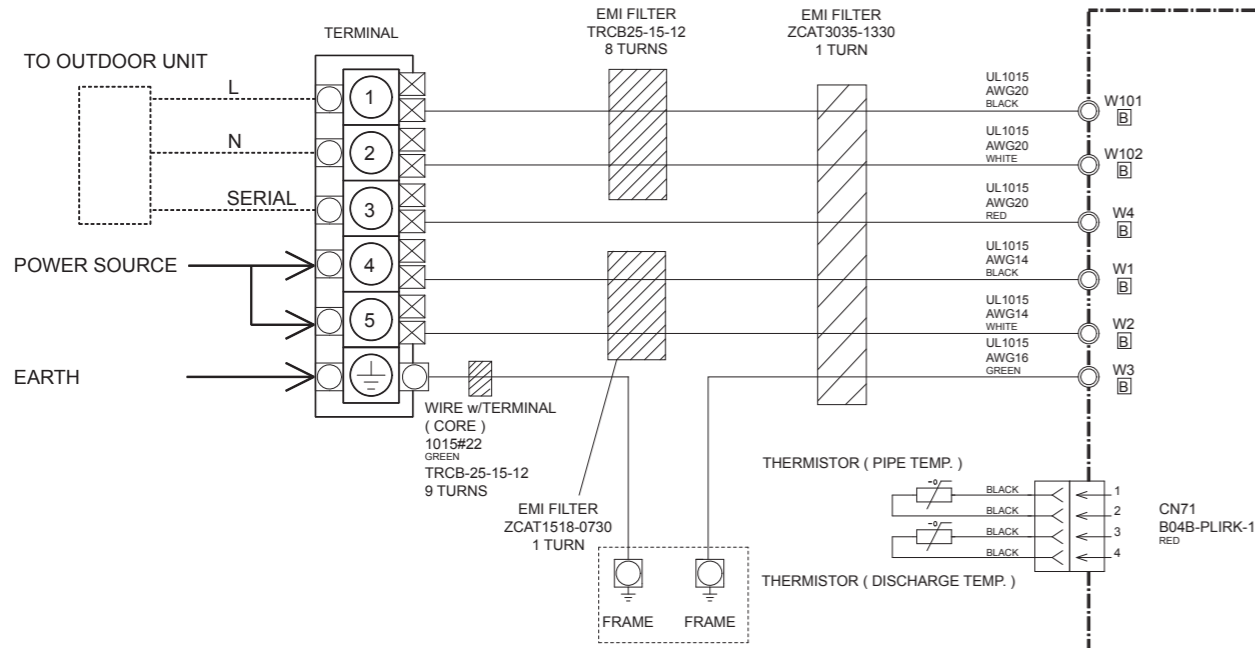

CN71 Thermistor Characteristics.

Thermistor	Temperature	0 °C	20 °C	30 °C
Thermistor ( Pipe temp. )		16.1 k Ω	6.0 k Ω	3.8 k Ω
		1.1 V	2.2 V	2.8 V
Thermistor ( Discharge temp. )		168.6 k Ω	62.6 k Ω	40.0 k Ω
		0.4 V	0.9 V	1.2 V

CN70 Thermistor Characteristics.

Thermistor	Temperature	0 °C	20 °C	30 °C
Thermistor ( Outdoor temp. )		35.2 k Ω	12.6 k Ω	8.0 k Ω
		2.6 V	3.8 V	4.1 V

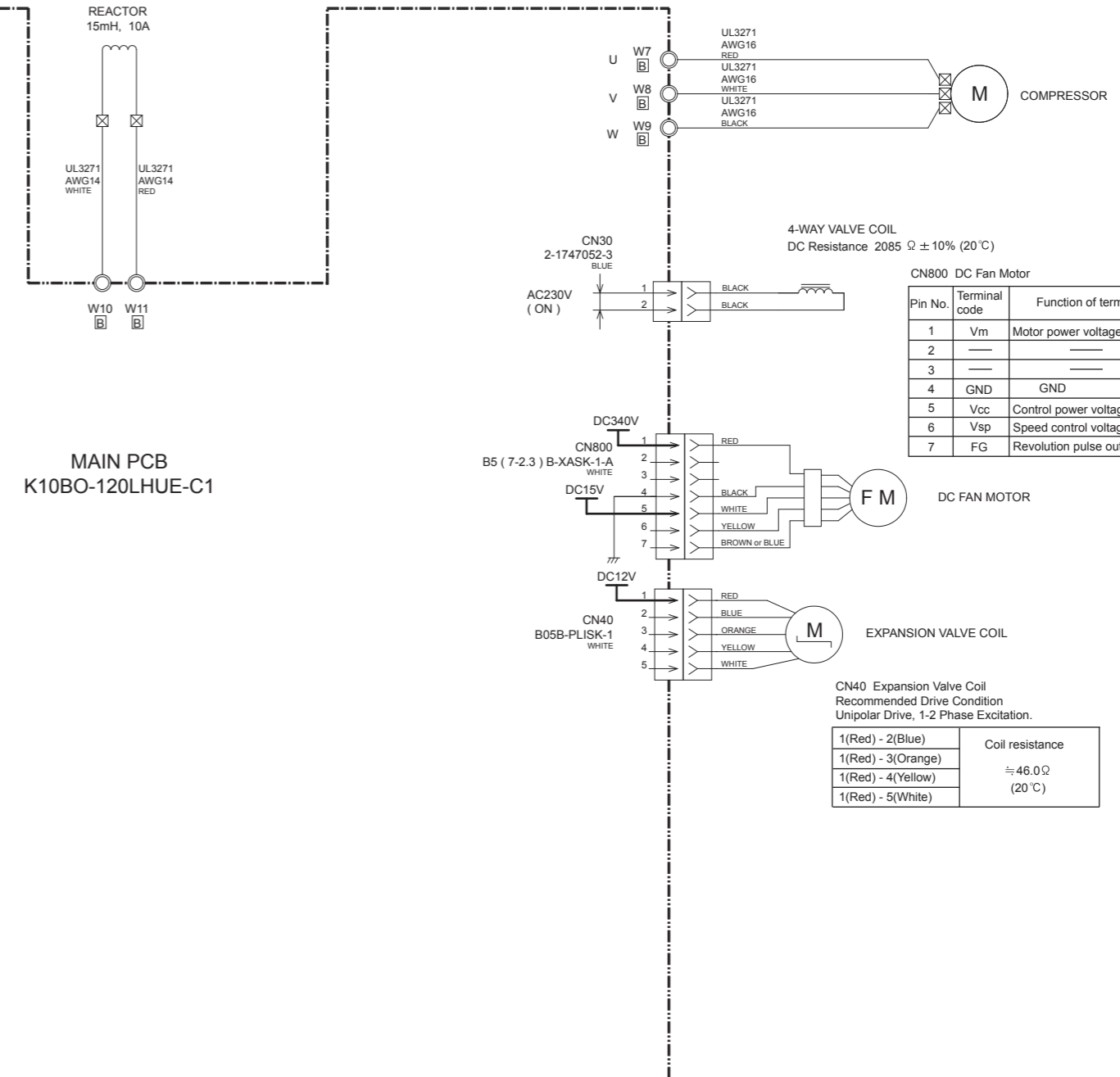

Compressor Winding Resistance

U-V	0.71 Ω (20 °C)
V-W	
U-W	



# ERROR DETECTION

If you use a wireless remote control, the lamp on the photo detector unit will output error codes by way of blinking patterns.

If you use a wired remote control, error codes will appear on the remote control display. See the lamp blinking patterns and error codes in the table. An error display is displayed only during operation.

## Troubleshooting with the indoor unit display

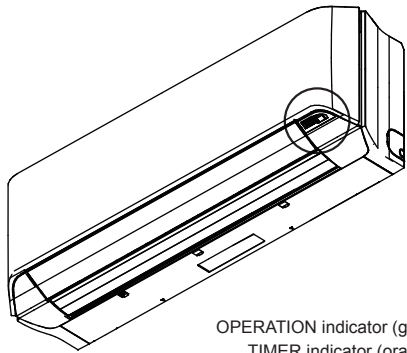

OPERATION indicator (green)

TIMER indicator (orange)

ECONOMY indicator (green)

## Troubleshooting with the Wired Remote Control Display (Option)

If an error occurs, the following display will be shown. ("Er" will appear in the set room temperature display.)



Error display			Wired remote controller Error code	Description
OPERATION lamp (green)	TIMER lamp (orange)	ECONOMY lamp (green)		
●(1)	●(1)	◇	11	Serial communication error
●(1)	●(2)	◇	12	Wired remote controller communication error
●(1)	●(5)	◇	15	Check run unfinished
●(2)	●(1)	◇	21	Unit number or Refrigerant circuit address setting error [Simultaneous Multi]
●(2)	●(2)	◇	22	Indoor unit capacity error
●(2)	●(3)	◇	23	Combination error
●(2)	●(4)	◇	24	• Connection unit number error (indoor slave unit) [Simultaneous Multi] • Connection unit number error (indoor unit or branch unit) [Flexible Multi]
●(2)	●(7)	◇	27	Master unit, slave unit set-up error [Simultaneous Multi]
●(3)	●(2)	◇	32	Indoor unit PCB model information error
●(3)	●(5)	◇	35	Manual auto switch error
●(4)	●(1)	◇	41	Room temp. sensor error
●(4)	●(2)	◇	42	Indoor unit Heat Ex. Middle temp. sensor error
●(5)	●(1)	◇	51	Indoor unit fan motor error
●(5)	●(3)	◇	53	Drain pump error
●(5)	●(7)	◇	57	Damper error
●(5)	●(8)	◇	58	Intake grille error
●(5)	●(15)	◇	5U	Indoor unit error
●(6)	●(2)	◇	62	Outdoor unit main PCB model information error or communication error
●(6)	●(3)	◇	63	Inverter error
●(6)	●(4)	◇	64	Active filter error, PFC circuit error
●(6)	●(5)	◇	65	Trip terminal L error

●(6)	●(10)	◇	6A	Display PCB microcomputers communication error
●(7)	●(1)	◇	71	Discharge temp. sensor error
●(7)	●(2)	◇	72	Compressor temp. sensor error
●(7)	●(3)	◇	73	Outdoor unit Heat Ex. liquid temp. sensor error
●(7)	●(4)	◇	74	Outdoor temp. sensor error
●(7)	●(5)	◇	75	Suction Gas temp. sensor error
●(7)	●(6)	◇	76	• 2-way valve temp. sensor error • 3-way valve temp. sensor error
●(7)	●(7)	◇	77	Heat sink temp. sensor error
●(8)	●(2)	◇	82	• Sub-cool Heat Ex. gas inlet temp. sensor error • Sub-cool Heat Ex. gas outlet temp. sensor error
●(8)	●(3)	◇	83	Liquid pipe temp. sensor error
●(8)	●(4)	◇	84	Current sensor error
●(8)	●(6)	◇	86	• Discharge pressure sensor error • Suction pressure sensor error • High pressure switch error
●(9)	●(4)	◇	94	Trip detection
●(9)	●(5)	◇	95	Compressor rotor position detection error
●(9)	●(7)	◇	97	Outdoor unit fan motor error
●(9)	●(9)	◇	99	4-way valve error
●(10)	●(1)	◇	A1	Discharge temp. error
●(10)	●(3)	◇	A3	Compressor temp. error
●(10)	●(4)	◇	A4	High pressure error
●(10)	●(5)	◇	A5	Low pressure error
●(13)	●(2)	◇	J2	Branch boxes error [Flexible Multi]

Display mode ● : 0.5s ON / 0.5s OFF  
◇ : 0.1s ON / 0.1s OFF  
( ) : Number of flashing

### OUTDOOR UNIT

Indicator lamp	Error
on	Discharge temperature error
0.5 second on / 0.5 second off	IPM overcurrent protection
0.1 second on / 0.1 second off	Thermistor error
2.0 second on / 2.0 second off	CT error
0.1 second on / 2.0 second off	Compressor location error
5.0 second on / 5.0 second off	Fan error

# PARTS

INDOOR UNIT  
ASYG14LMCE

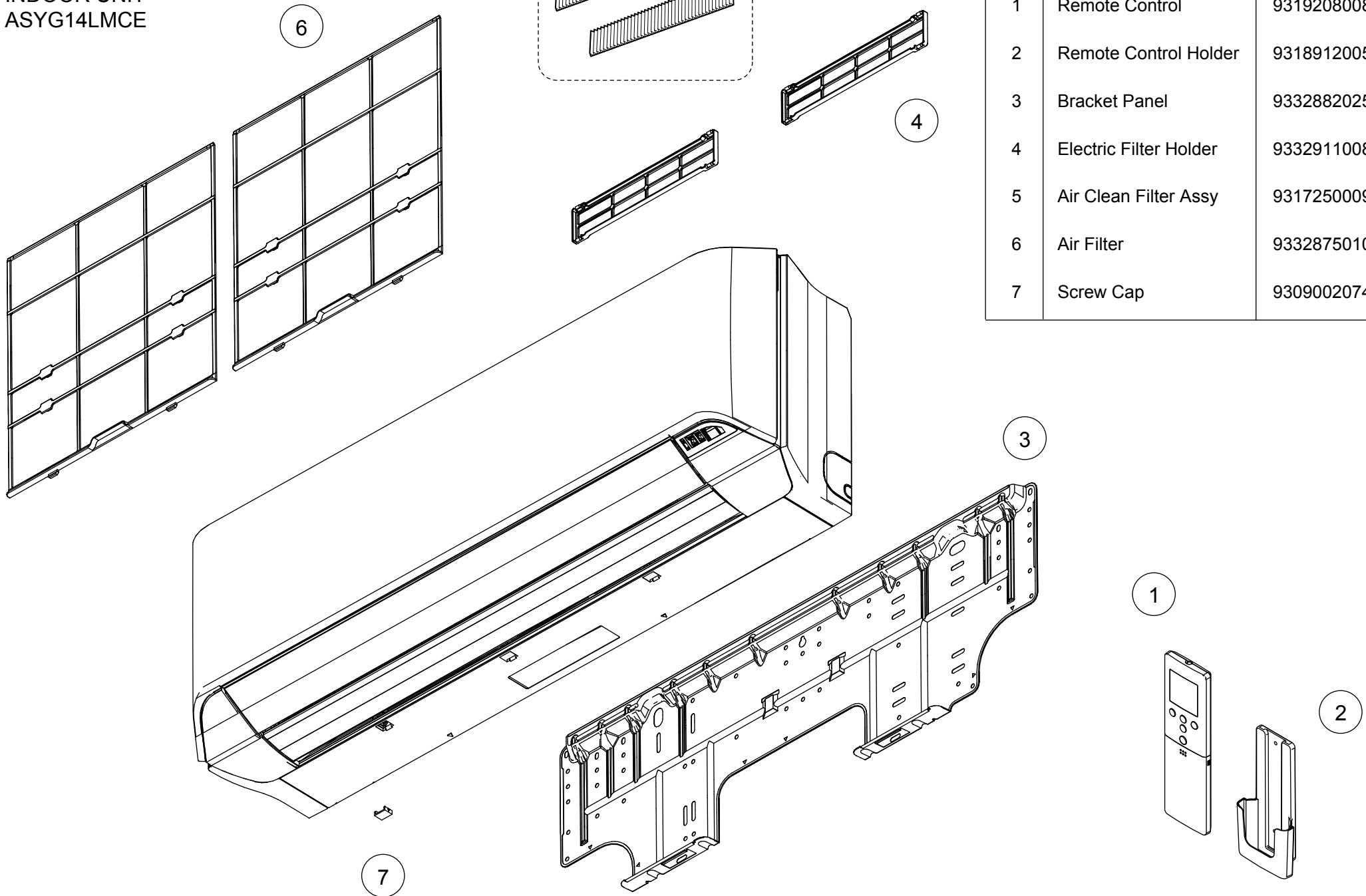

Ref.	Description	Part number
1	Remote Control	9319208008
2	Remote Control Holder	9318912005
3	Bracket Panel	9332882025
4	Electric Filter Holder	9332911008
5	Air Clean Filter Assy	9317250009
6	Air Filter	9332875010
7	Screw Cap	9309002074

INDOOR UNIT  
ASYG14LMCE

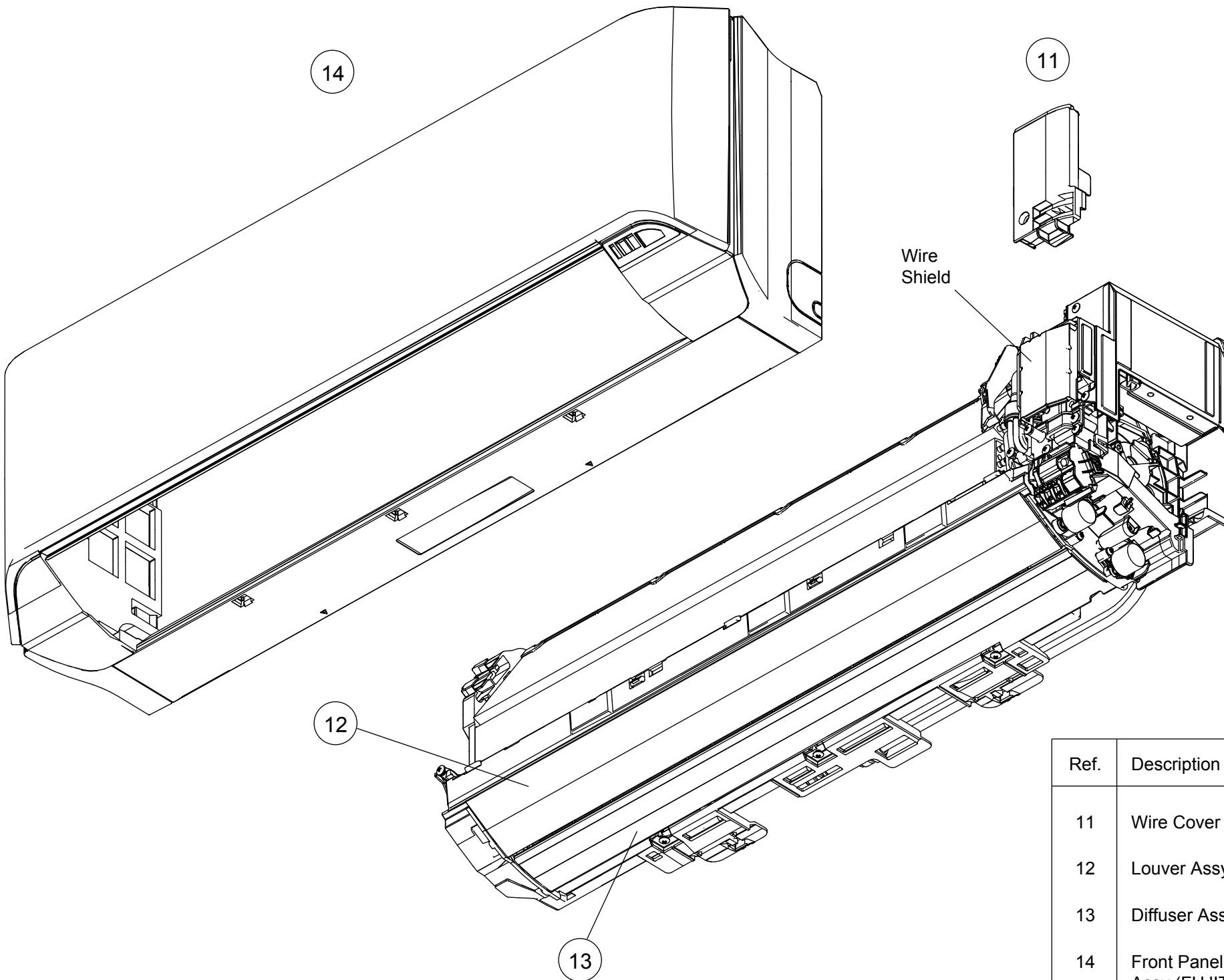

Ref.	Description	Part number
11	Wire Cover	9333504018
12	Louver Assy	9333353043
13	Diffuser Assy	9332998085
14	Front Panel Sub Assy (FUJITSU)	9333525051

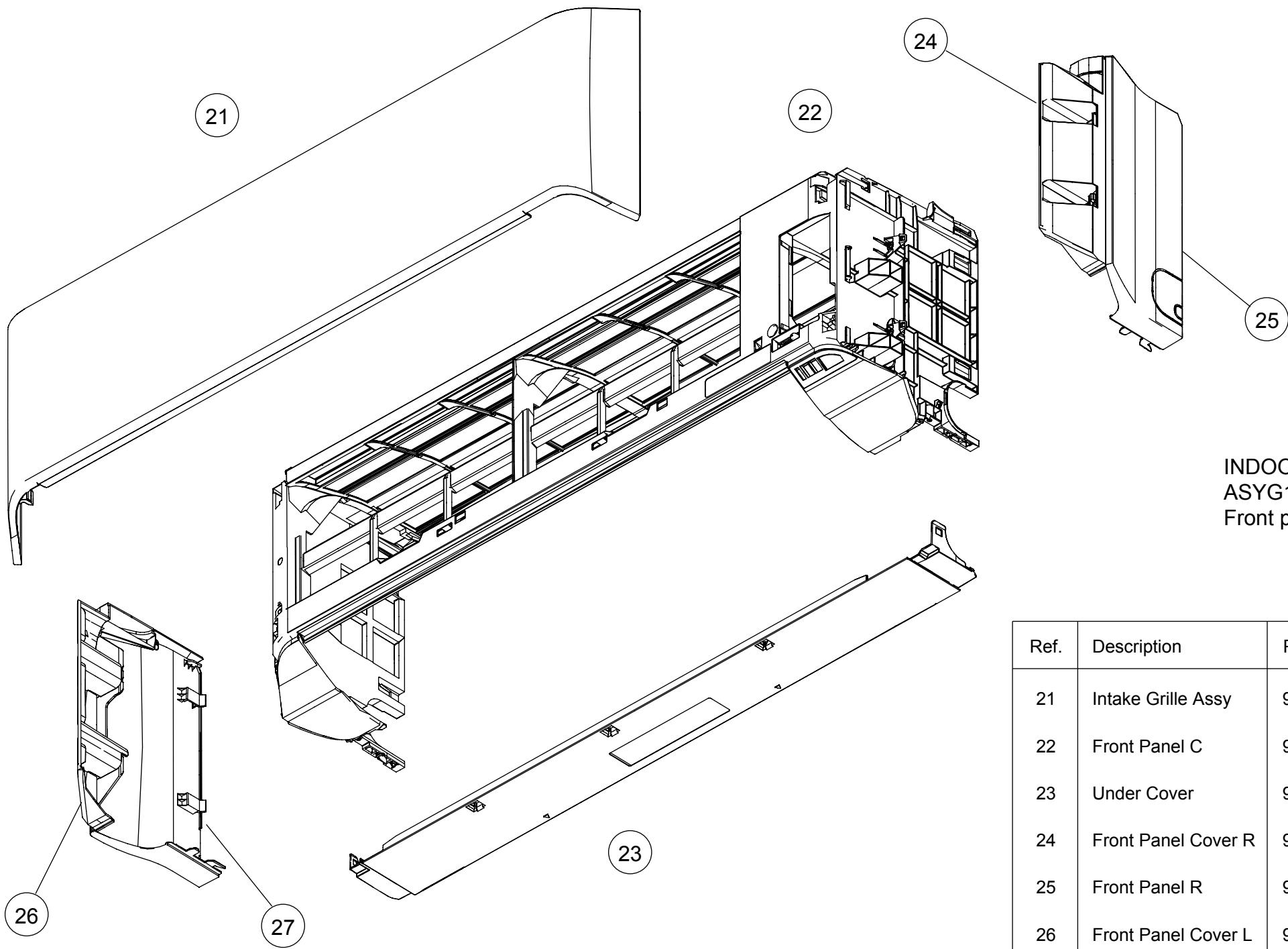

INDOOR UNIT  
ASYG14LMCE  
Front panel sub assy

Ref.	Description	Part number
21	Intake Grille Assy	9333526010
22	Front Panel C	9333497020
23	Under Cover	9333503011
24	Front Panel Cover R	9333502014
25	Front Panel R	9333500003
26	Front Panel Cover L	9333501017
27	Front Panel L	9333499000

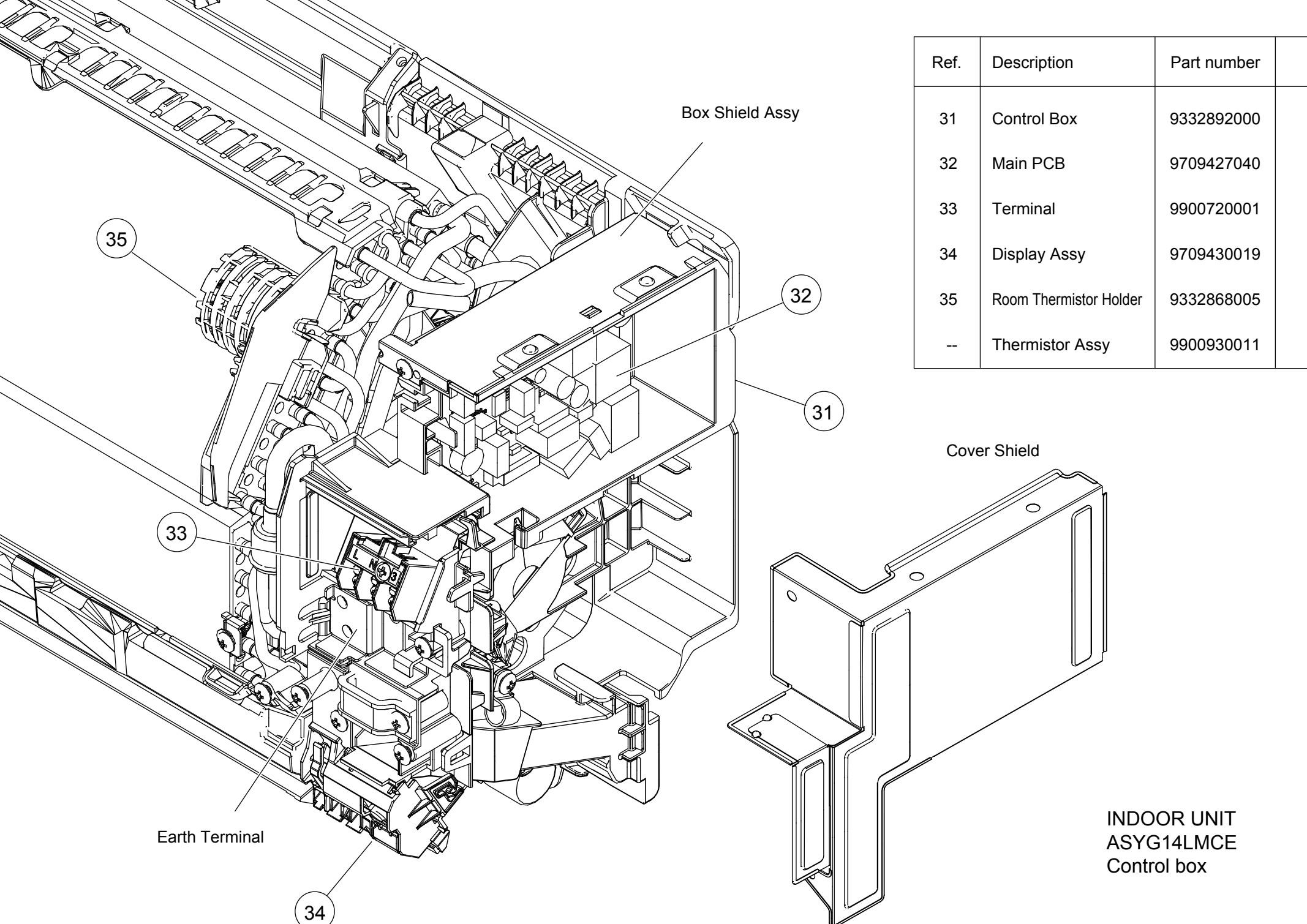

Ref.	Description	Part number
31	Control Box	9332892000
32	Main PCB	9709427040
33	Terminal	9900720001
34	Display Assy	9709430019
35	Room Thermistor Holder	9332868005
--	Thermistor Assy	9900930011

INDOOR UNIT  
ASYG14LMCE  
Control box

INDOOR UNIT  
 ASYG14LMCE  
 Evaporator  
 Fan

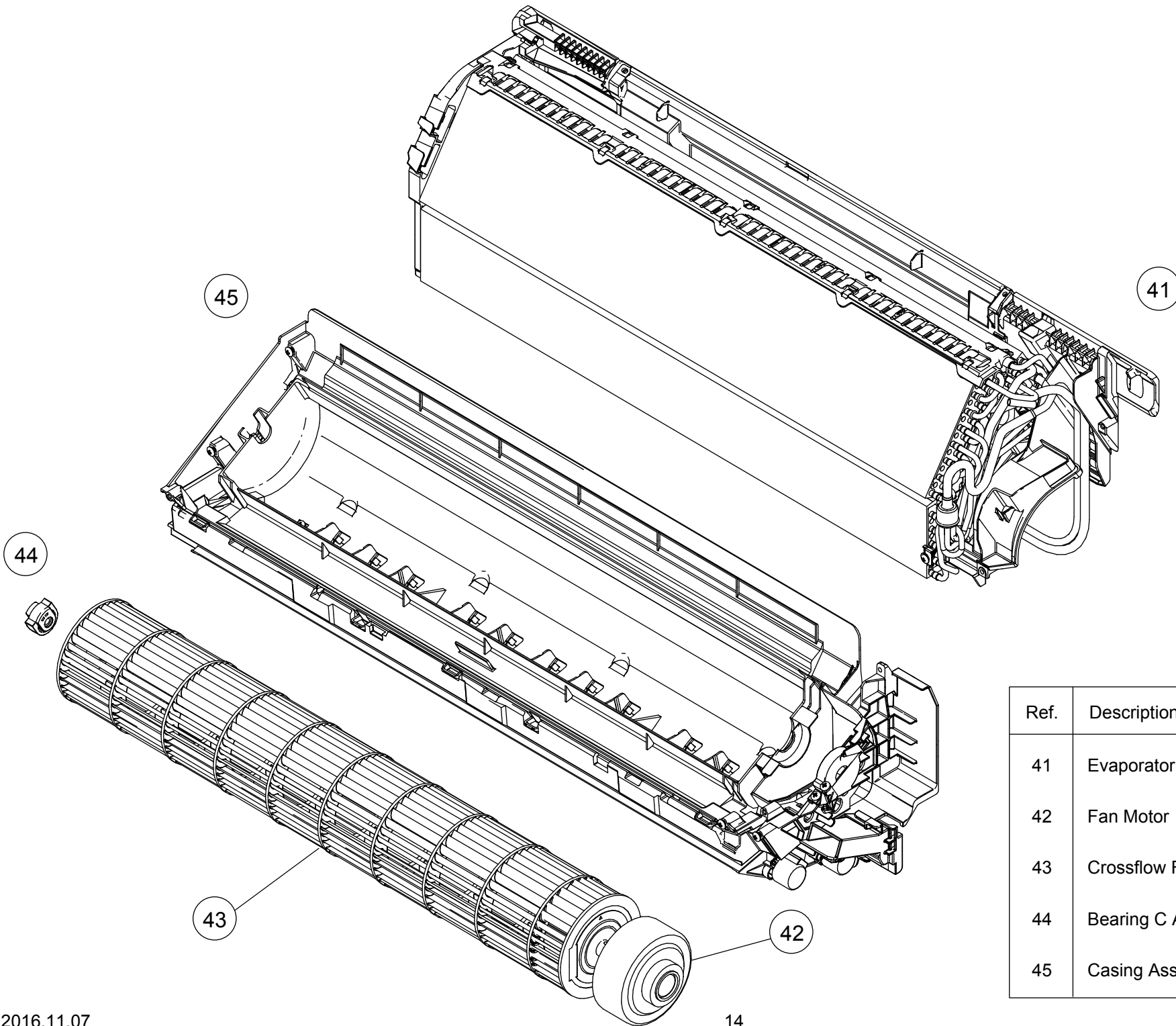

Ref.	Description	Part number
41	Evaporator Total Assy	9332989113
42	Fan Motor	9603269005
43	Crossflow Fan Assy	9316830004
44	Bearing C Assy	9306628017
45	Casing Assy	9333009001

INDOOR UNIT  
ASYG14LMCE  
Casing assy

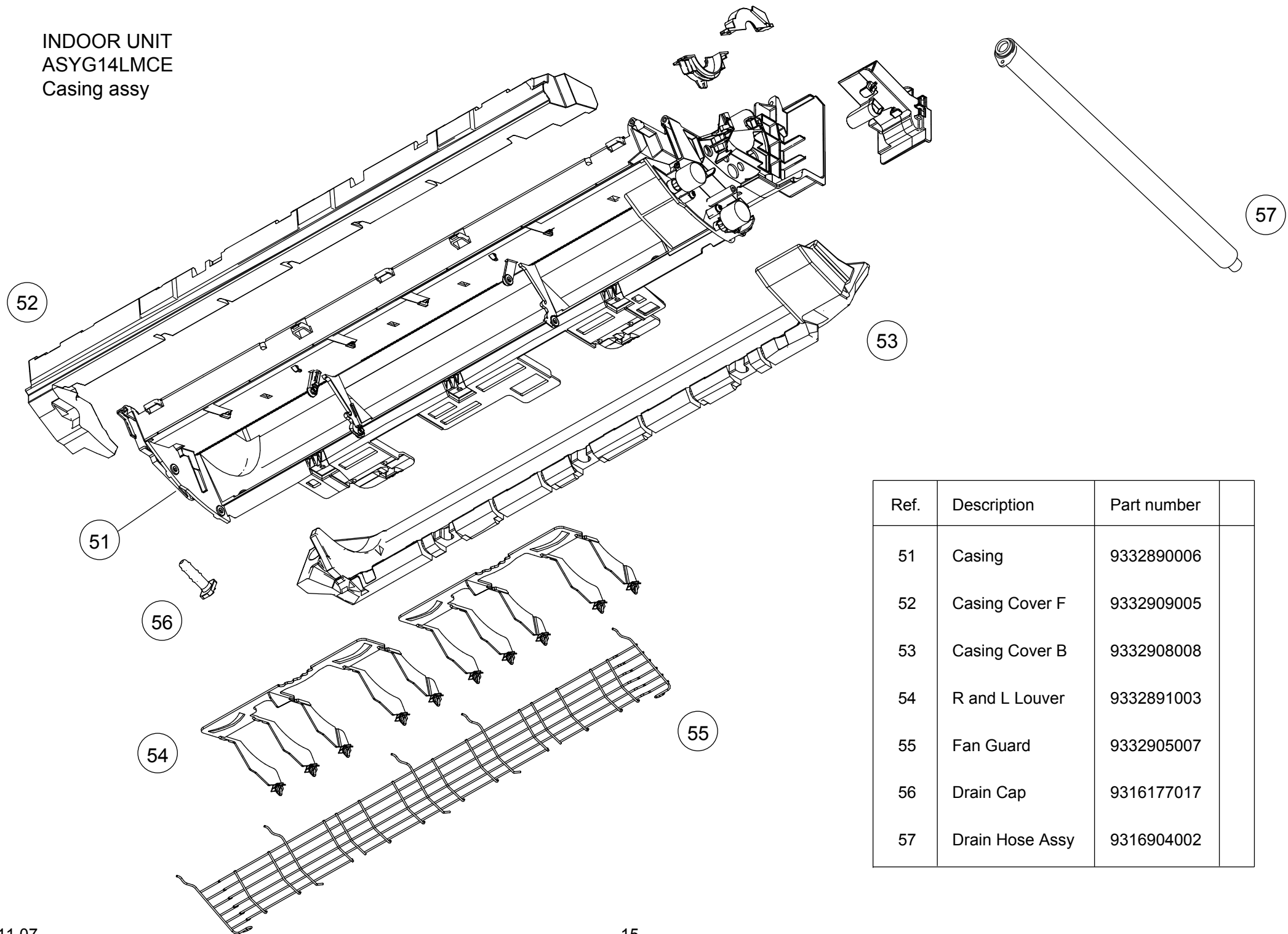

Ref.	Description	Part number	
51	Casing	9332890006	
52	Casing Cover F	9332909005	
53	Casing Cover B	9332908008	
54	R and L Louver	9332891003	
55	Fan Guard	9332905007	
56	Drain Cap	9316177017	
57	Drain Hose Assy	9316904002	



INDOOR UNIT  
 ASYG14LMCE  
 Casing assy

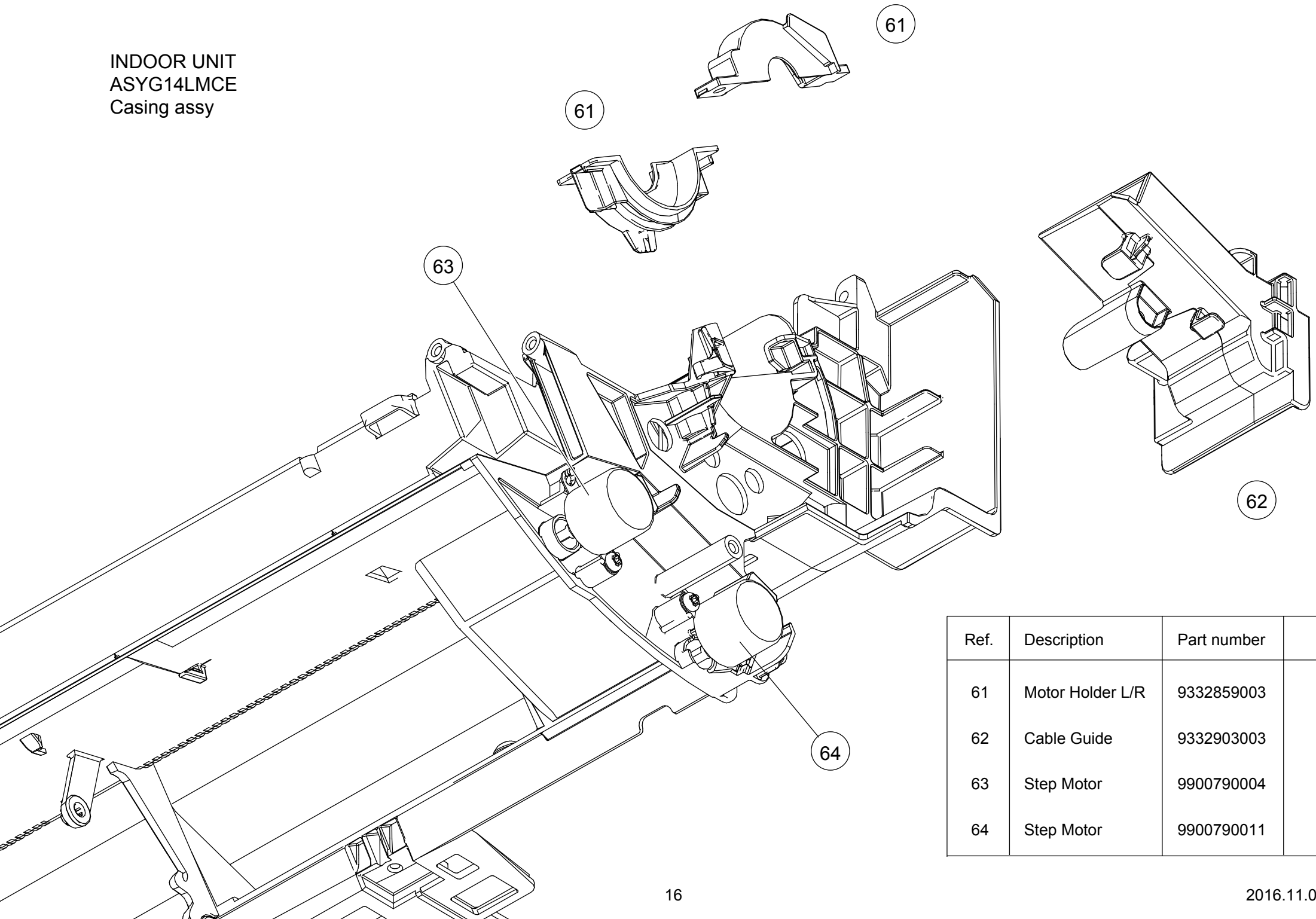

Ref.	Description	Part number
61	Motor Holder L/R	9332859003
62	Cable Guide	9332903003
63	Step Motor	9900790004
64	Step Motor	9900790011

# PARTS

OUTDOOR UNIT  
AOYG14LMCE

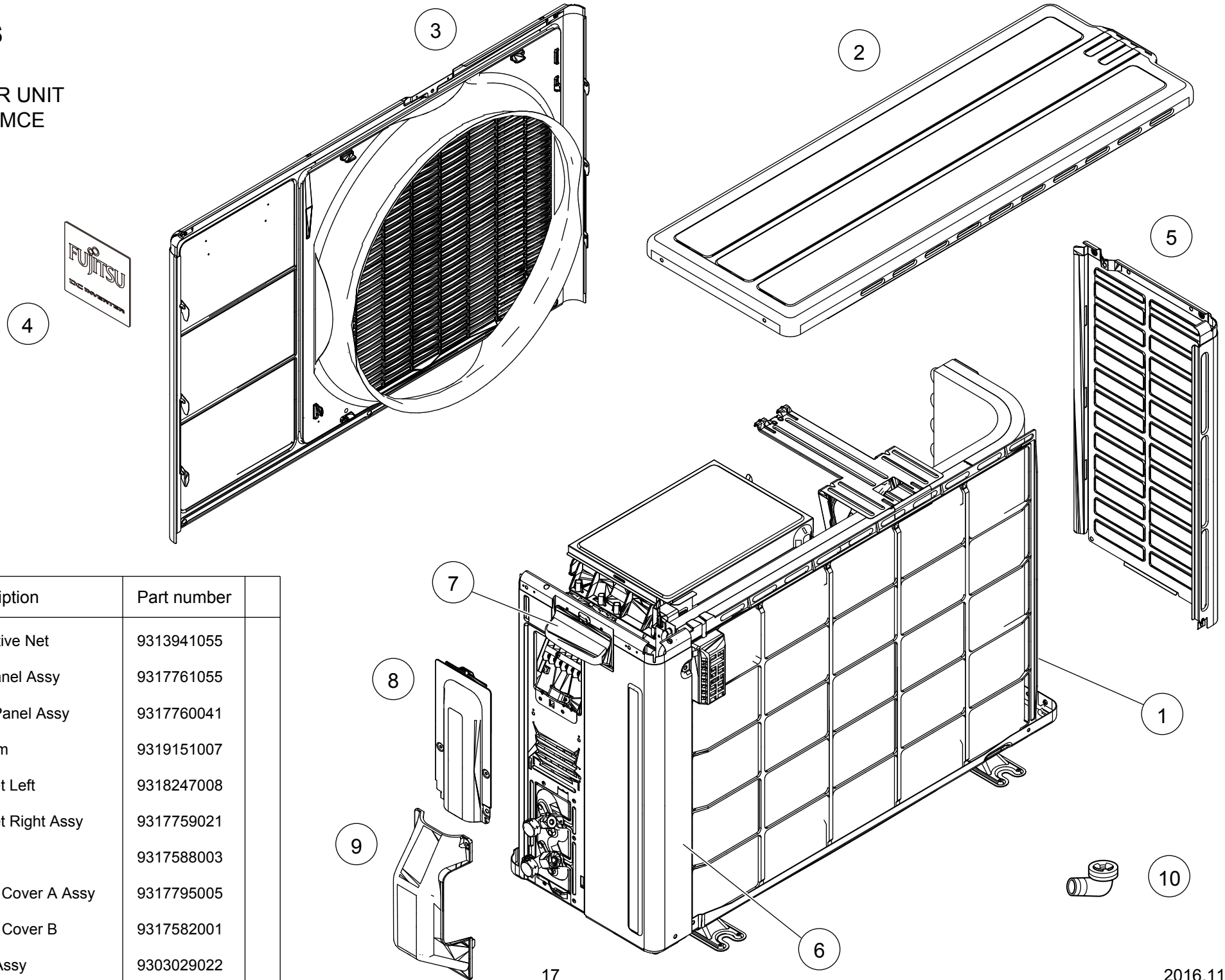

Ref.	Description	Part number
1	Protective Net	9313941055
2	Top Panel Assy	9317761055
3	Front Panel Assy	9317760041
4	Emblem	9319151007
5	Cabinet Left	9318247008
6	Cabinet Right Assy	9317759021
7	Grip	9317588003
8	Switch Cover A Assy	9317795005
9	Switch Cover B	9317582001
10	Drain Assy	9303029022

Ref.	Description	Part number
11	Propeller Fan	9313808013
12	Fan Motor	9602864041
13	Reactor Assy	9900788018
14	Terminal	9900435028

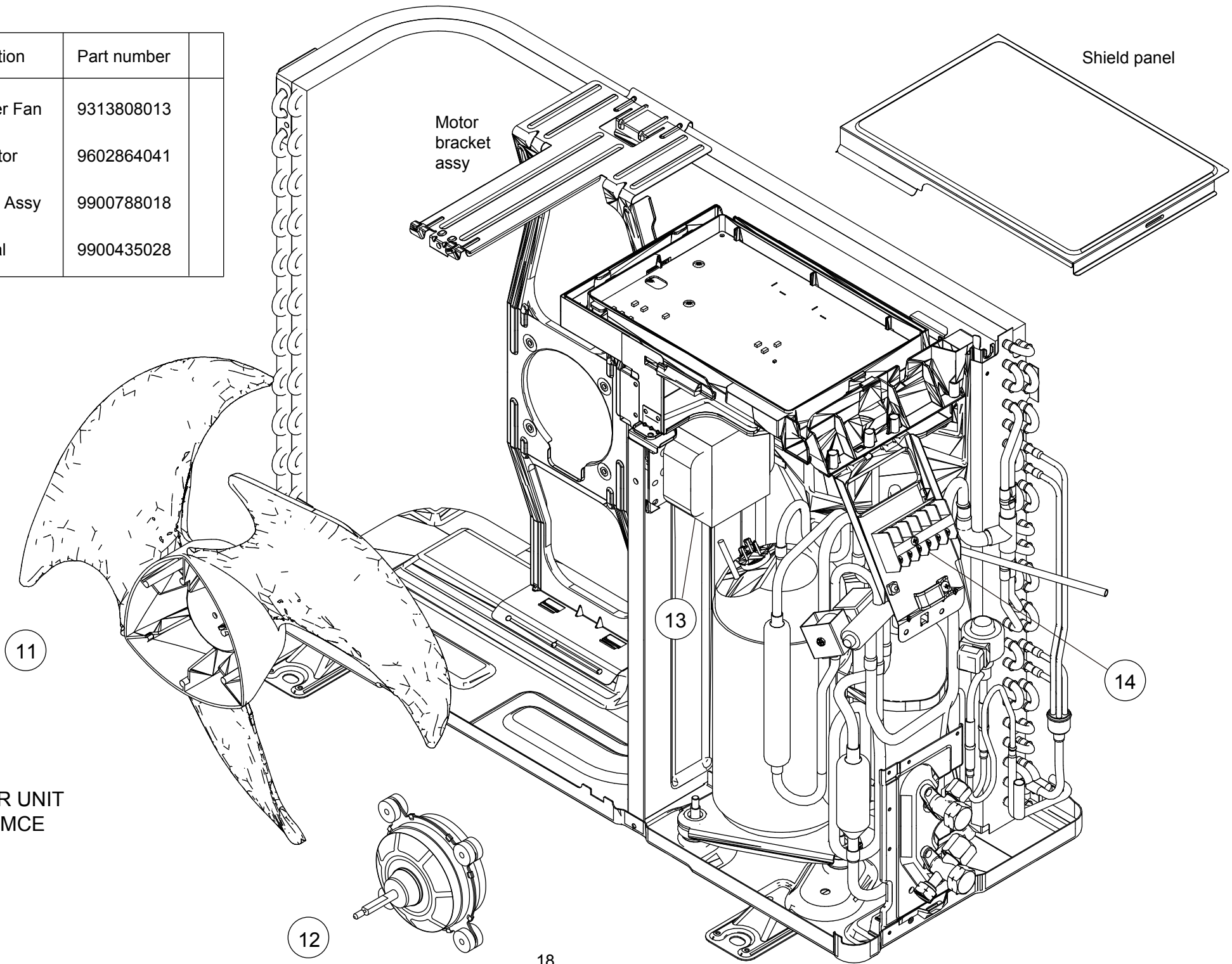

OUTDOOR UNIT  
AOYG14LMCE

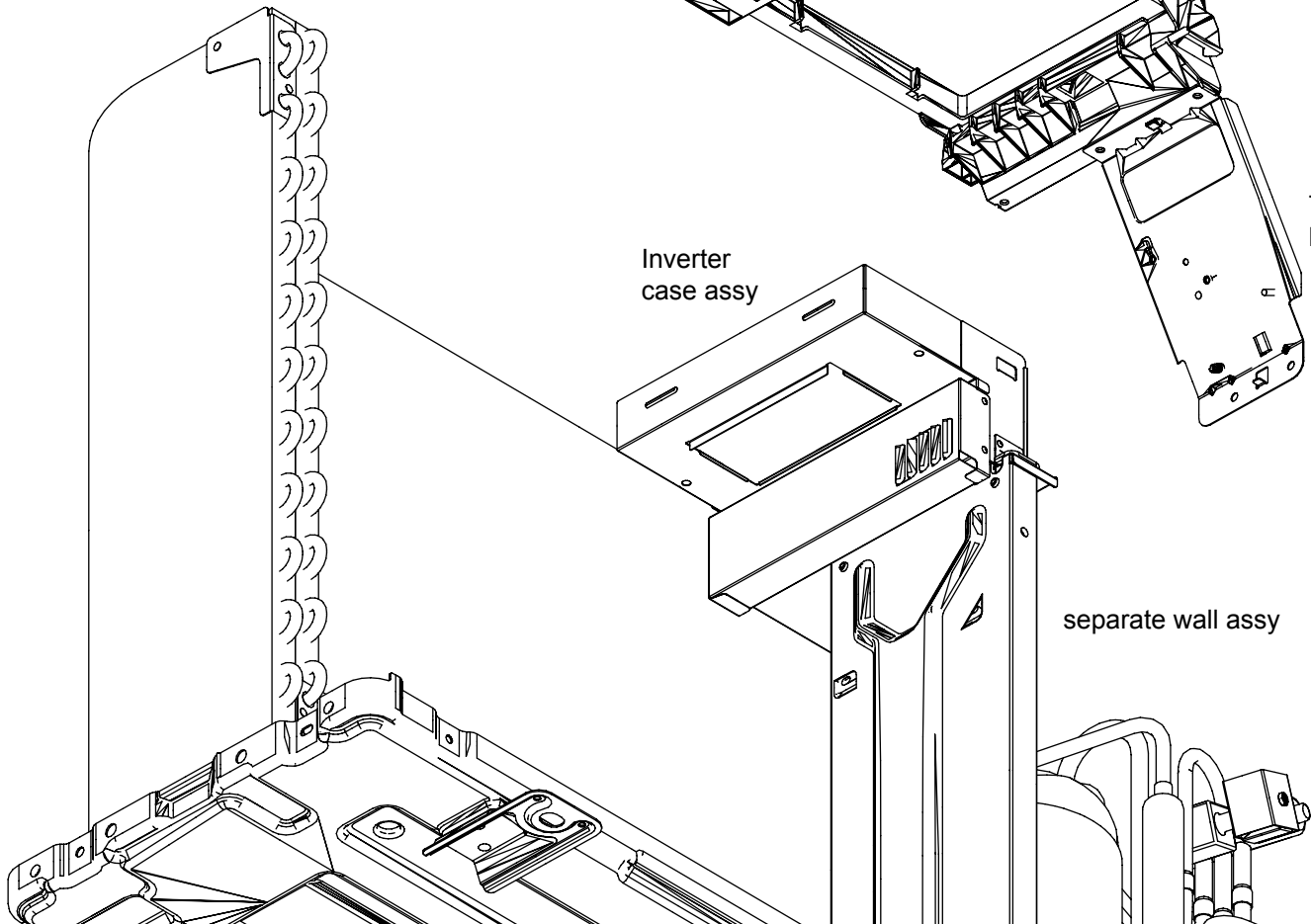
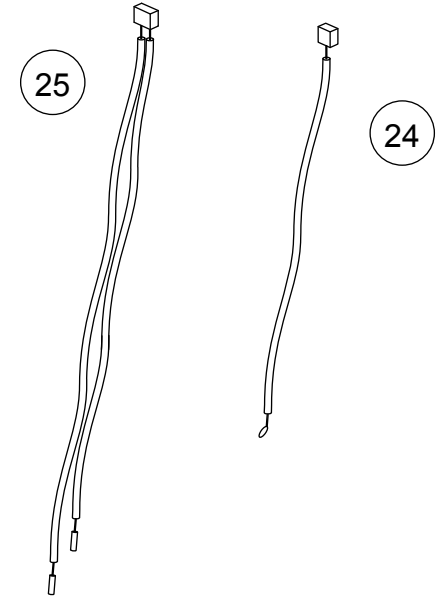
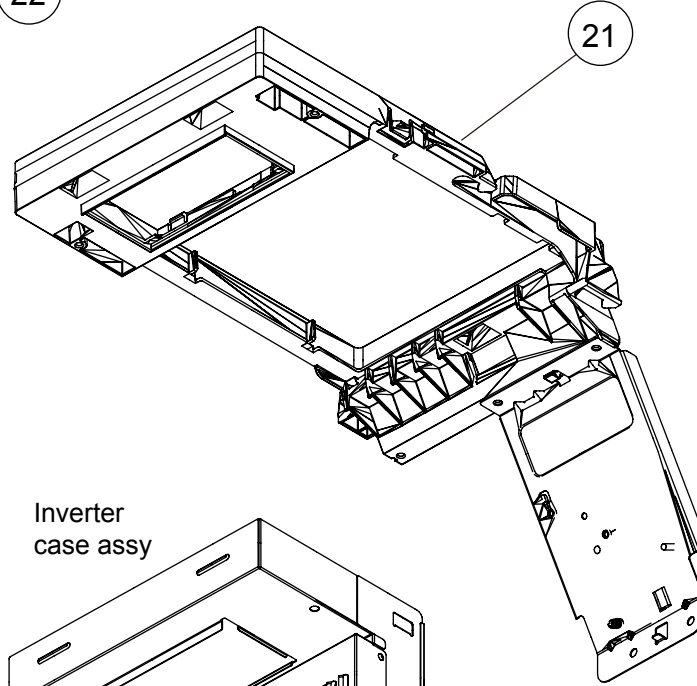
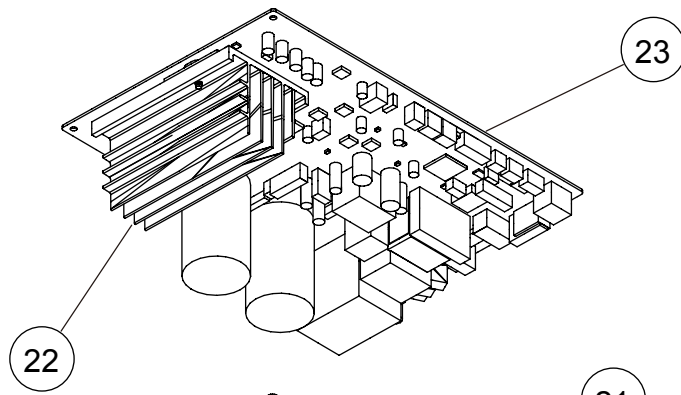

Terminal  
bracket

Inverter  
case assy

separate wall assy

Ref.	Description	Part number
21	PCB Holder	9318182002
22	Heat Sink	9319070001
23	Main PCB	9708682556
24	Outdoor Thermistor	9900565008
25	Thermistor Assy	9900628000

Ref.	Description	Part number
31	Condenser Total Assy	9332359008
32	Expansion Valve Coil	9970095030
33	Pulse Motor Valve Assy	9332368048
34	2-way Valve Assy	9332371000
35	3-way Valve Sub Assy	9317109055
36	4-way Valve Assy	9332365009
37	Solenoid	9970110023
38	Compressor Assy	9317619004

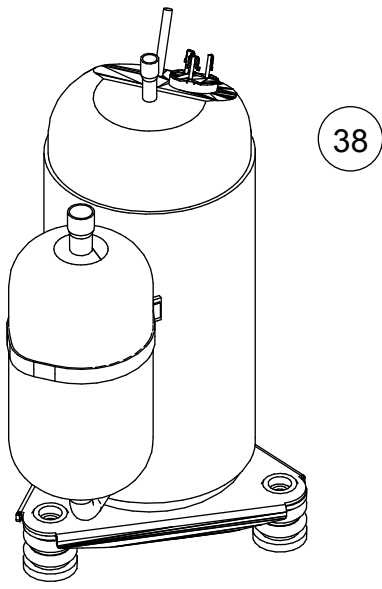

31

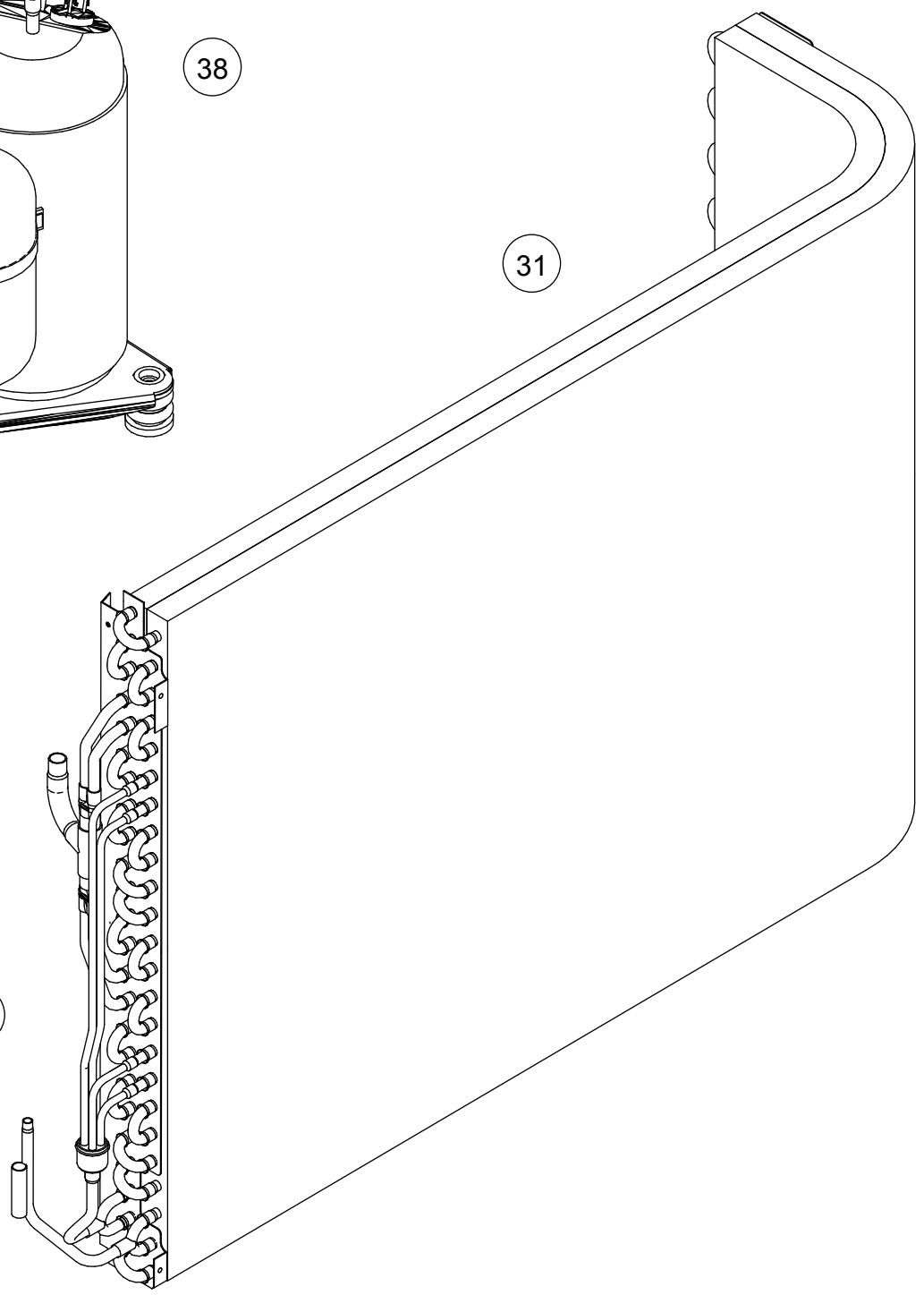

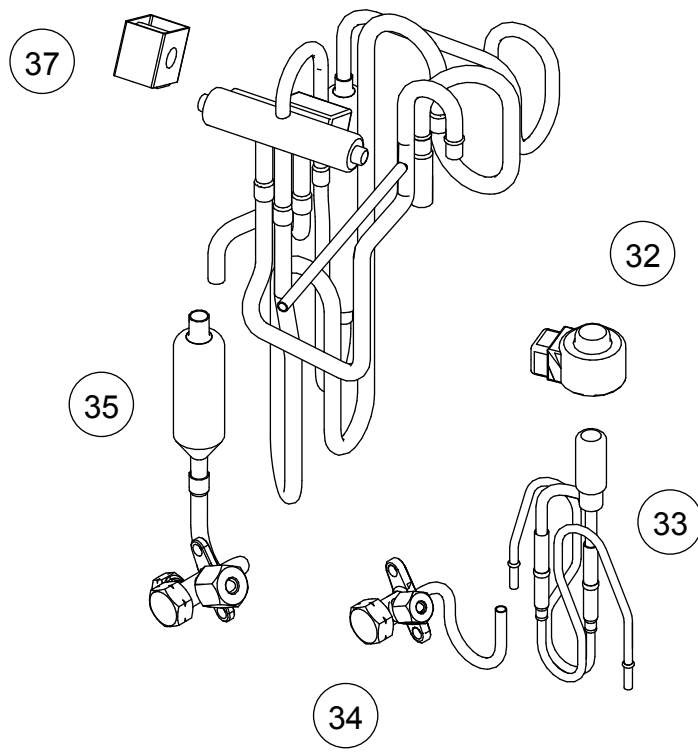

36



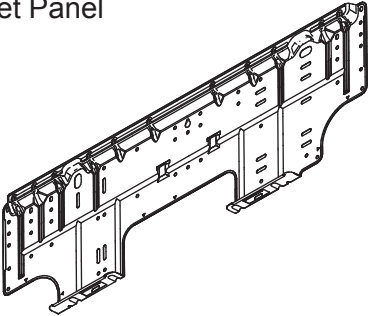
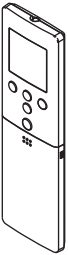
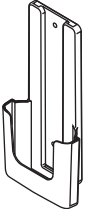

OUTDOOR UNIT  
AOYG14LMCE

# ACCESSORIES

## INDOOR UNIT

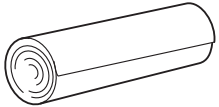
Name and Shape	Part number
Bracket Panel 	9332882025
Remote Control 	9319208008
Remote Control Holder 	9318912005
Battery (penlight) 	0600185541

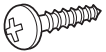
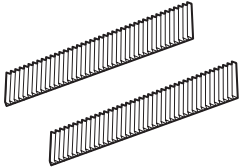
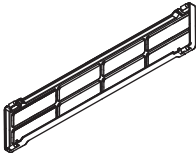
Name and Shape	Part number
Cloth tape 	9310519004
Tapping screw (M4 x 25 mm) 	0700076046
Tapping screw (M3 x 12 mm) 	0700019036
Air cleaning filter assy 	9317250009
Filter holder 	9332911008

## OUTDOOR UNIT

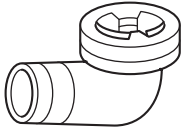
Name and Shape	Part number
Drain pipe assy 	9303029022

1611G4554