

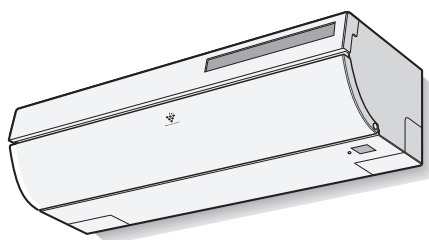

# SERVICE MANUAL

## S530612XPHRN/C



## SPLIT TYPE AIR TO AIR HEAT PUMP

### MODEL 12PHR-N

The interests of user-safety(Required by safety regulations in some countries)the set should be restored to its original condition and only parts identical to those specified should be used.

## CONTENTS

### CHAPTER 1. PRODUCT SPECIFICATION

[1] SPECIFICATION.....	1-1
[2] EXTERNAL DIMENSION.....	1-2
[3] WIRING DIAGRAM.....	1-3
[4] ELECTRICAL PARTS.....	1-4

### CHAPTER 2. EXPLANATION OF CIRCUIT AND OPERATION

[1] BLOCK DIAGRAMS.....	2-1
[2] MICROCOMPUTER CONTROL SYSTEM....	2-3
[3] FUNCTION.....	2-8

### CHAPTER 3. FUNCTION AND OPERATION OF PROTECTIVE PROCEDURES

[1] PROTECTION DEVICE FUNCTIONS AND OPERATIONS.....	3-1
[2] AIR CONDITIONER OPERATION IN THERMISTOR ERROR.....	3-2
[3] THERMISTOR TEMPERATURE CHARACTERISTICS.....	3-4

[4] HOW TO OPERATE THE OUTDOOR UNIT INDEPENDENTLY.....	3-6
[5] GENERAL TROUBLESHOOTING CHART....	3-6
[6] MALFUNCTION (PARTS) CHECK METHOD.....	3-7
[7] OUTDOOR UNIT CHECK METHOD.....	3-9
[8] SELF-DIAGNOSIS FUNCTION.....	3-11
[9] CHART FOR READING SELF-DIAGNOSIS RESULT.....	3-1

### CHAPTER 4. REFRIGERATION CYCLE

[1] SCHEMATIC DIAGRAM.....	4-1
[2] PERFORMANCE CURVES.....	4-1

### CHAPTER 5. DISASSEMBLING PROCEDURE

[1] INDOOR UNIT.....	5-1
[2] DISASSEMBLY OF OUTDOOR UNIT.....	5-5

### CHAPTER 6. OPERATION MANUAL

### CHAPTER 7. INSTALLATION MANUAL Parts Guide

Parts marked with "▲" are important for maintaining the safety of the set. Be sure to replace these parts with specified ones for maintaining the safety and performance of the set.

This document has been published to be used for after sales service only.  
The contents are subject to change without notice.

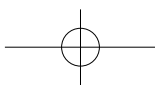
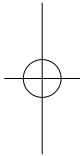
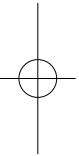
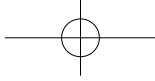

# CHAPTER 1. PRODUCT SPECIFICATION

## [1] SPECIFICATION

### 12PHR-N

ITEMS			MODEL	INDOOR UNIT	OUTDOOR UNIT
			12PHR-N		
Rated cooling capacity (Min. – Max.)		kW	3.5 (0.9 - 4.0)		
Rated heating capacity (Min. – Max.)		kW	4.6 (0.9 - 6.5)		
Moisture removal		Liters/h	1.2		
Phase			Single		
Rated frequency		Hz	50		
Rated voltage		V	230		
Rated current ☆ (Min. – Max.)	Cool	A	4.2 (0.9 - 5.7)		
	Heat	A	5.0 (0.8 - 8.0)		
Rated input ☆ (Min - Max.)	Cool	W	920 (200 - 1250)		
	Heat	W	1060 (160 - 1700)		
Power factor ☆	Cool	%	95		
	Heat	%	92		
Maximum operating current		A	9.6		
Compressor	Type		Twin Rotary		
	Model		GMCC DA115S1B-27ZF		
	Oil Charge		ESTER OIL VG74 450cc		
Refrigerant system	Evaporator		Louvre Fin and Grooved tube type		
	Condenser		Corrugate Fin and Grooved tube type		
	Control		Expansion valve		
	Refrigerant (R410A)		1180 g		
	De-Ice system		Micro computer controled reversed systems		
Noise level(at cooling)	High	dB(A)	40	47	
	Low	dB(A)	-	-	
	Soft	dB(A)	27	-	
Drive			Direct drive		
Air flow quantity(at cooling)	High	m <sup>3</sup> /min.	9.3	32.2	
	Low	m <sup>3</sup> /min.	7.6	-	
	Soft	m <sup>3</sup> /min.	5.2	-	
Fan			Cross flow fan	Propeller fan	
Refrigerant coupling			Flare type		
Refrigerant tube size Gas,Liquid			3/8" ( Φ 9.53 mm), 1/4" ( Φ 6.35 mm)		
Drain piping		mm	O.D. Φ16		

#### Others

Safety device			Compressor:Themistor		
			Fan motors :Inherent themistor		
			Fuse, Micro computer control		
Air filters			Polypropylene net (Washable)		
Net dimensions	Width	mm	798	780	
	Height	mm	260	540	
	Depth	mm	290	265	
Net weight		kg	15	39	

NOTE: The conditions of ( ☆ ) marked items are based om 'EN14511'.

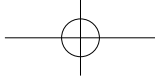

12PHR-N

## [2] EXTERNAL DIMENSION

### 1. Indoor unit

(Unit : mm)

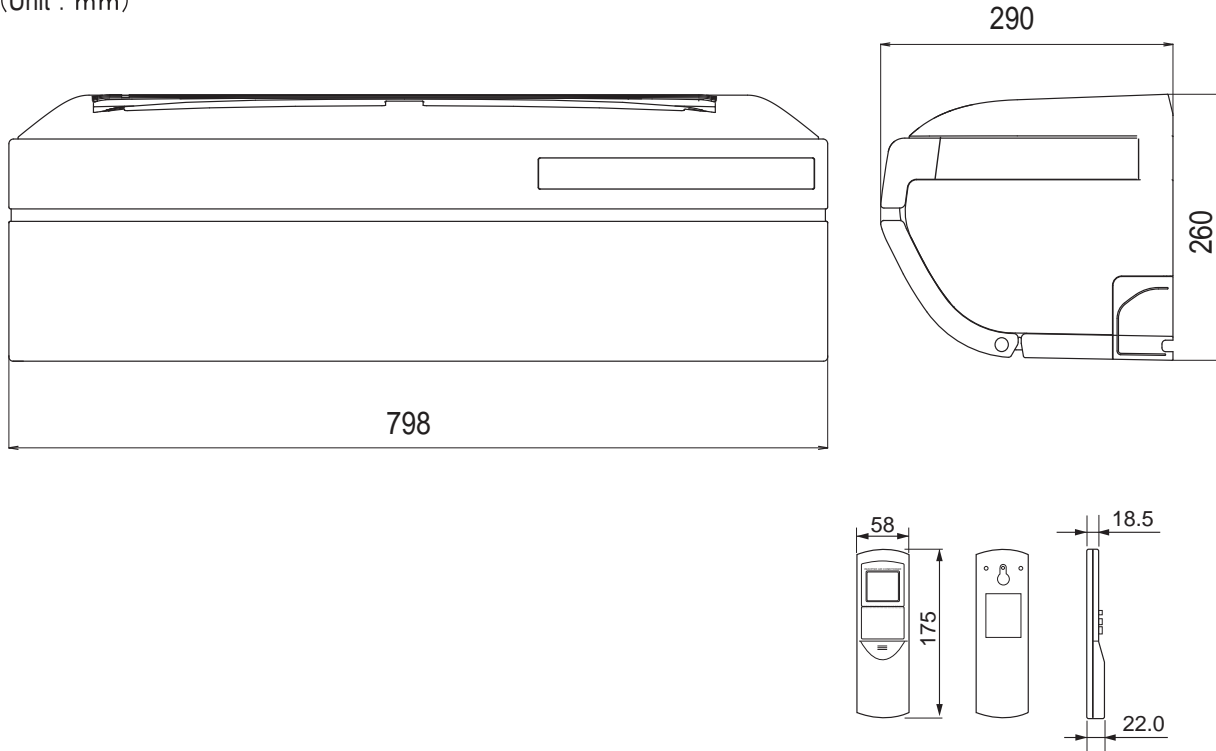

### 2. Outdoor unit

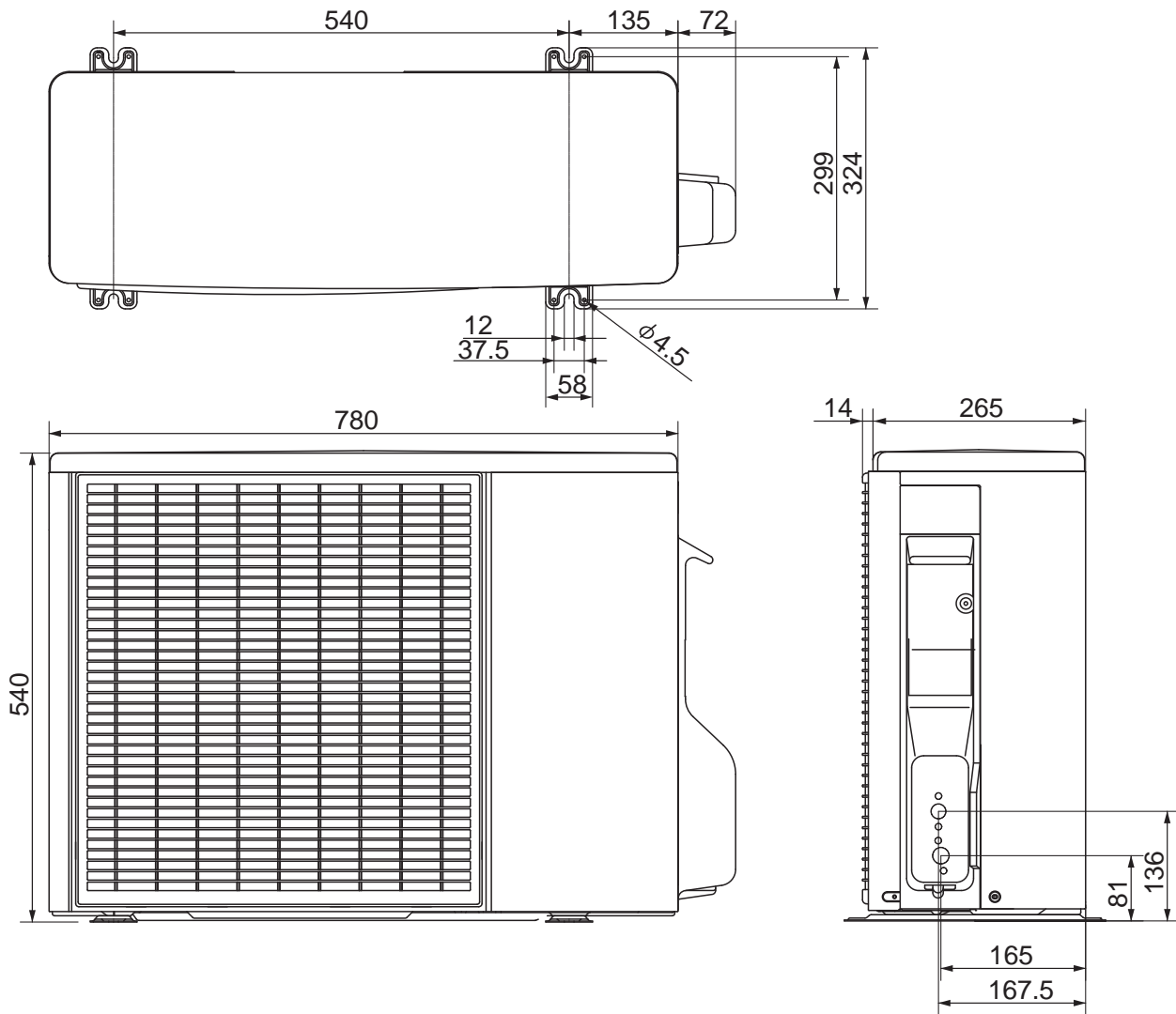

1-2

### [3] WIRING DIAGRAM

#### 1. Indoor unit

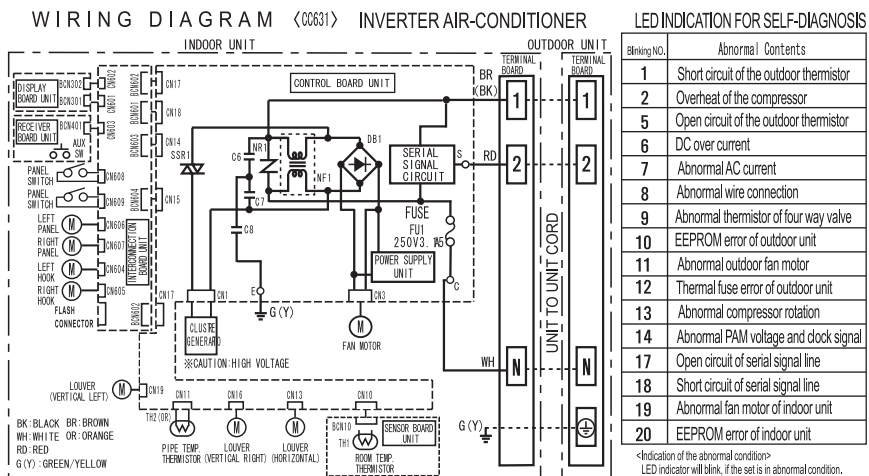

#### 2 Outdoor Unit

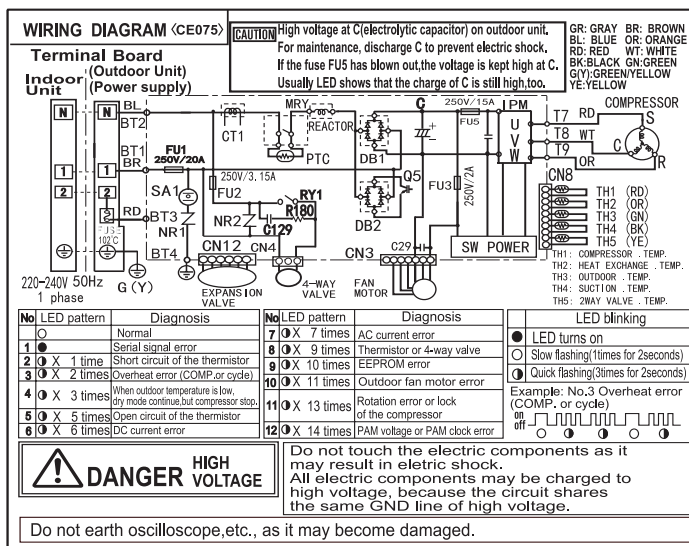

### [4] ELECTRICAL PARTS

#### 1. Indoor unit

DESCRIPTION	MODEL	REMARKS
Fan motor	MLB395	DC Motor
Fan motor capacitor	-	-
Transformer	-	-
Fu 1	-	QFS-GA078JBZZ (250V, 3.15A)

#### 2 Outdoor Unit

DESCRIPTION	MODEL	REMARKS
Compressor	DA115S1B-27FZ	DC Motor
Fan motor	ARW8403SH	DC Motor
Fu 3	-	QFS-GA077JBZZ(250V, 2A)
Fu 2	-	QFS-GA078JBZZ(250V, 3.15A)
FU1	-	QFS-CA001JBZZ(250V,20A)
FU5	-	QFS-CA002JBZZ(250V,15A)

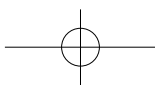
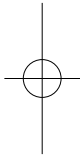
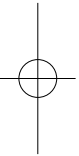
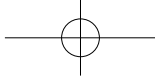

# CHAPTER 2. EXPLANATION OF CIRCUIT AND OPERATION

## [1] BLOCK DIAGRAMS

### 1. Indoor unit

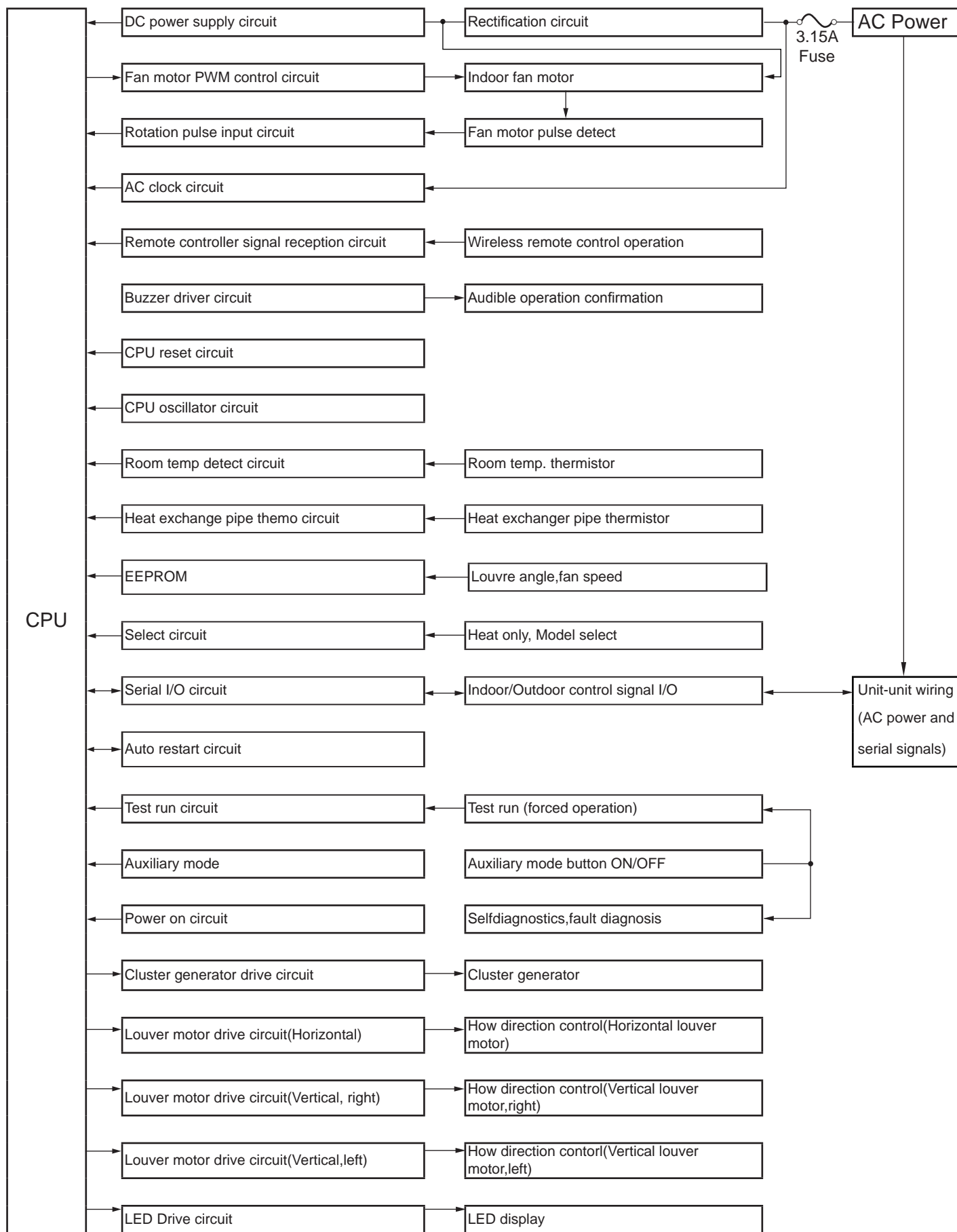

2. Outdoor unit

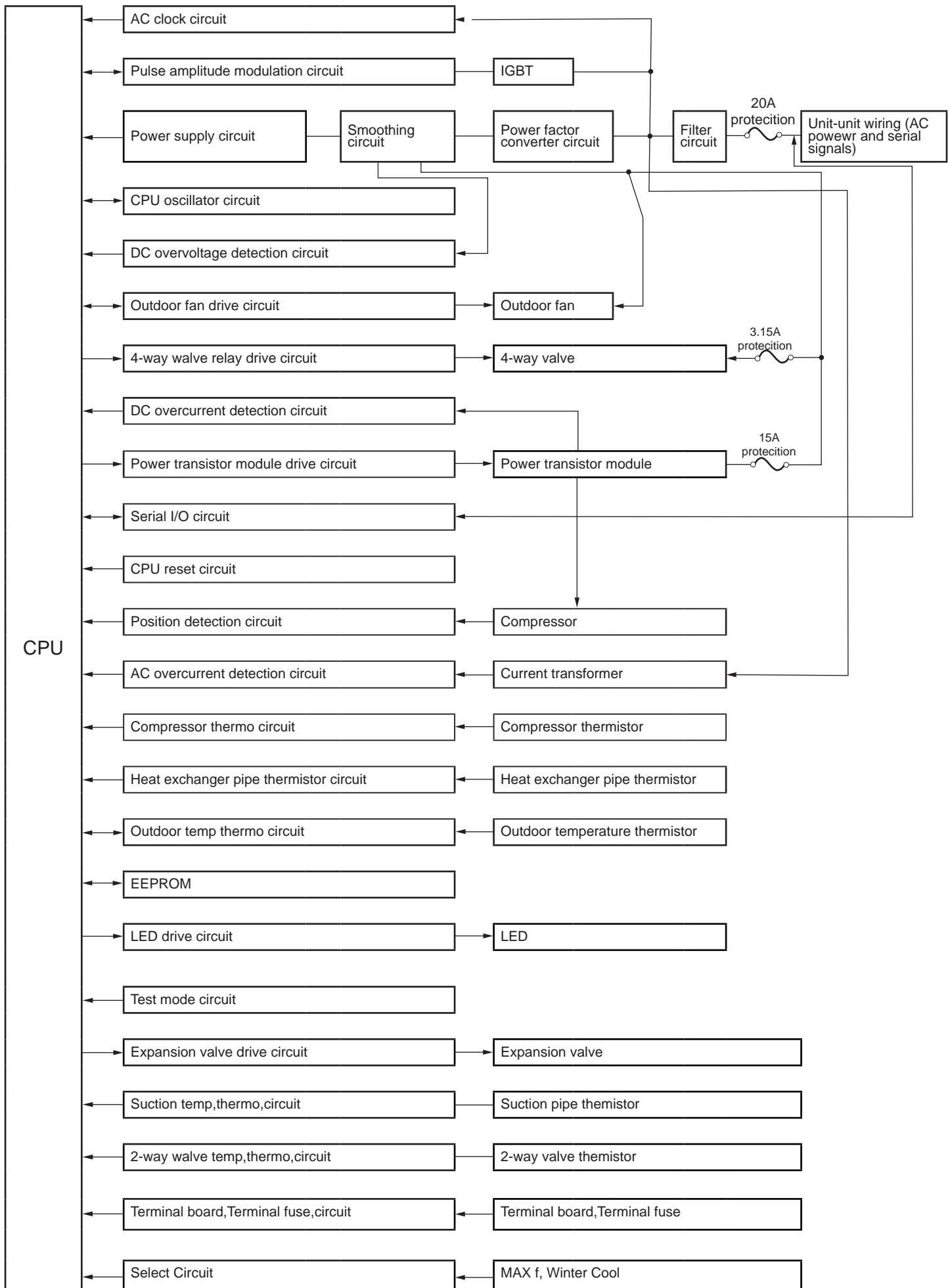



# [2] MICROCOMPUTER CONTROL SYSTEM

## 1. Indoor unit

### 1.1. Electronic control circuit diagram

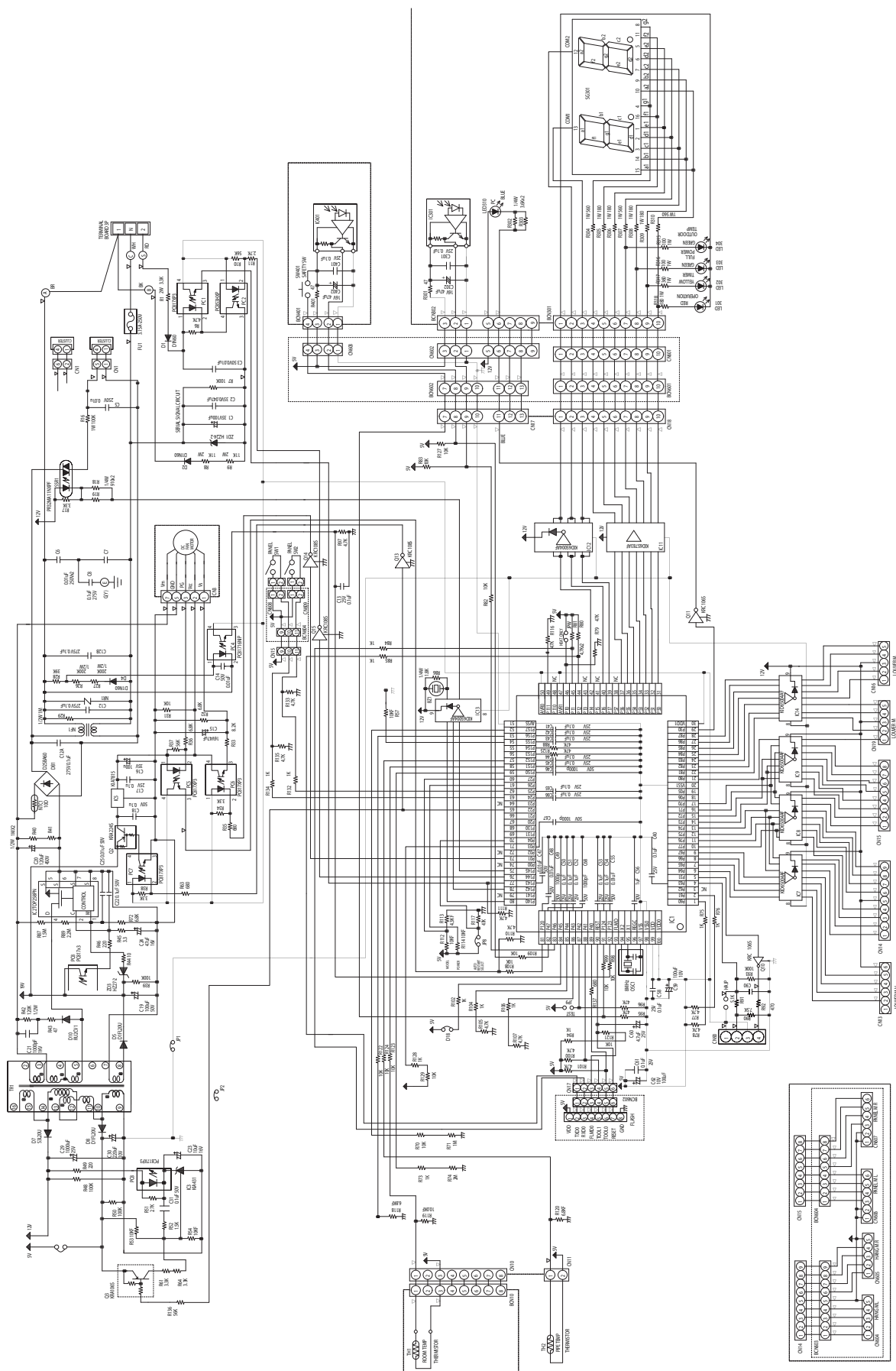

# 12PHR-N

## 1.2. Display circuit diagram

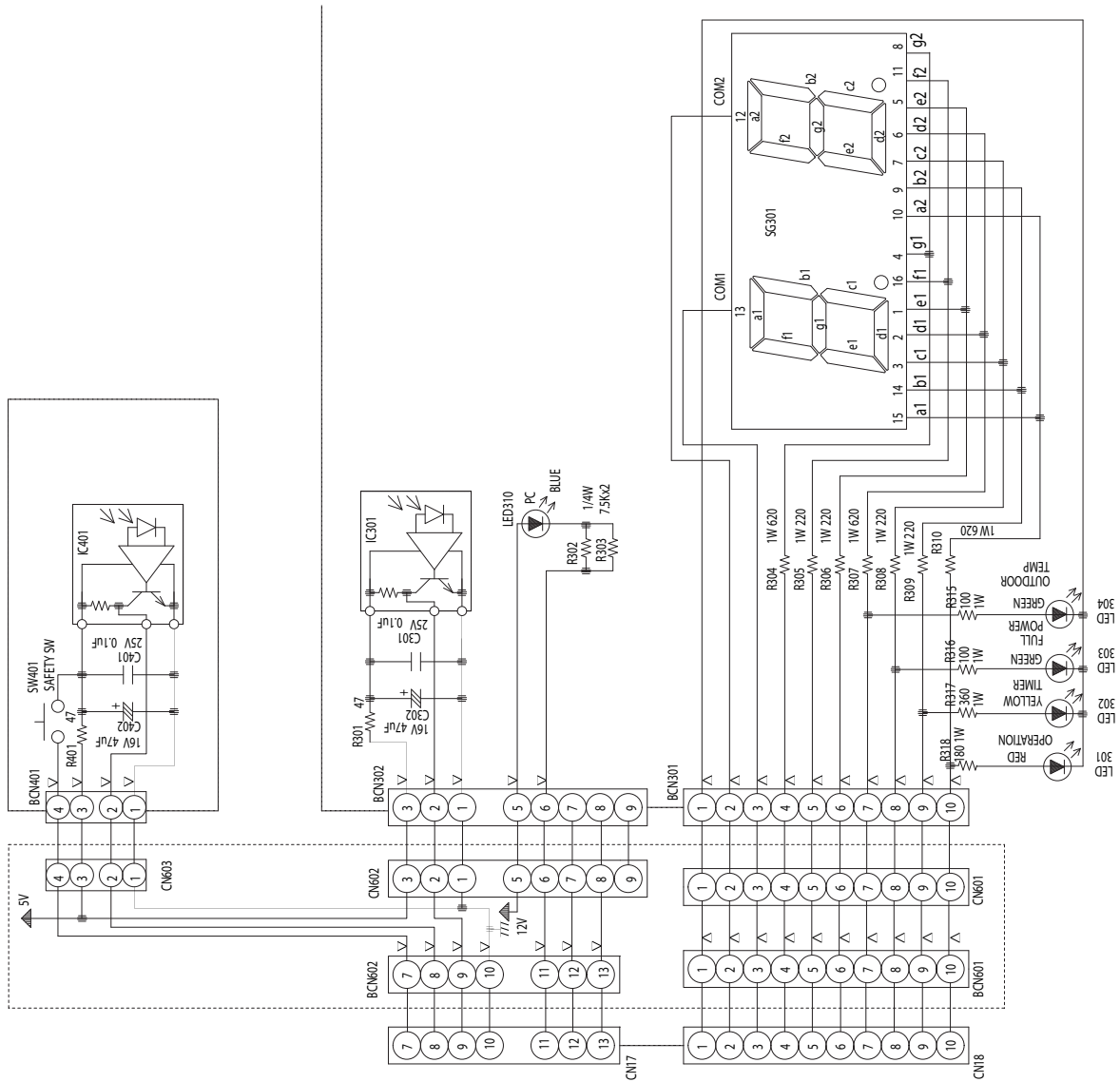

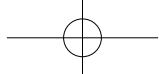

1.3. Printed wiring board

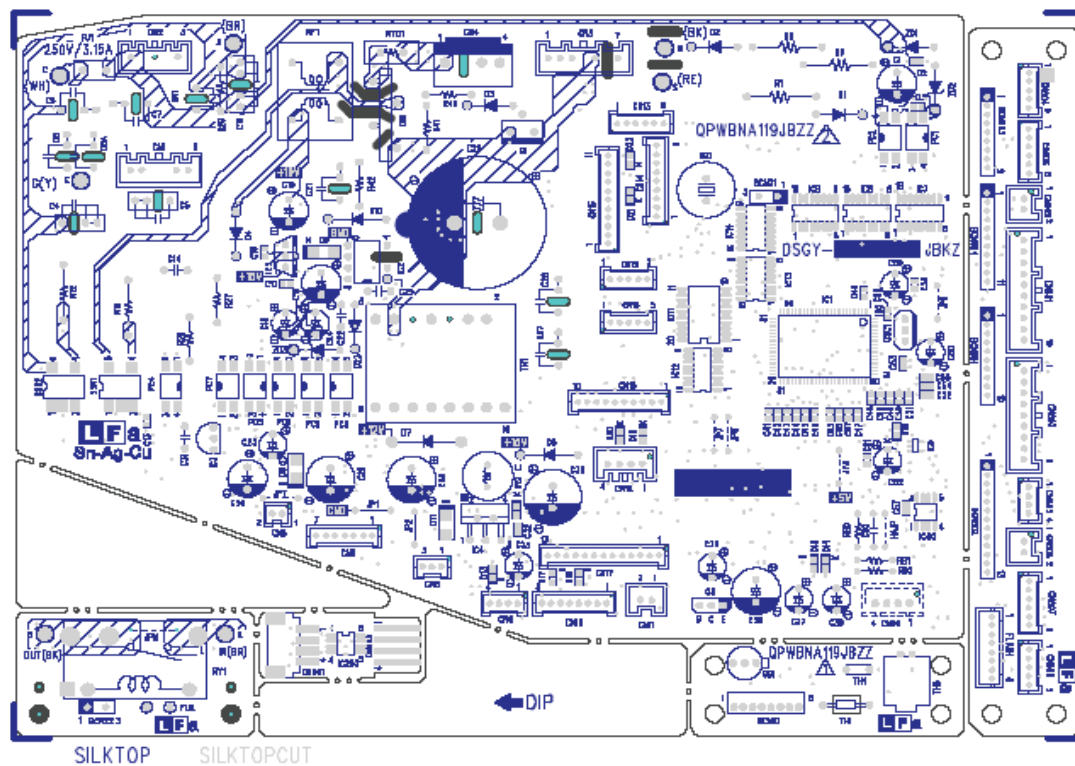

For Connection PWB

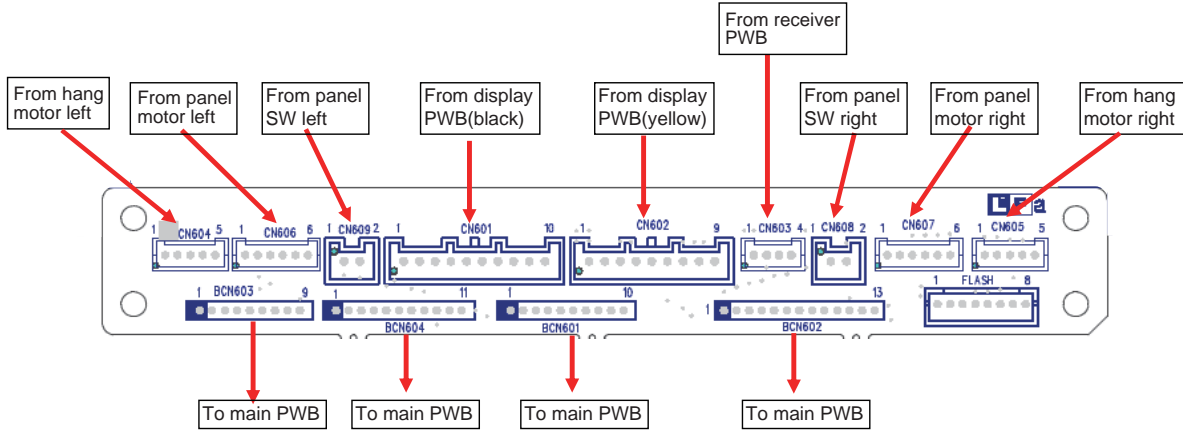

For Display PWB

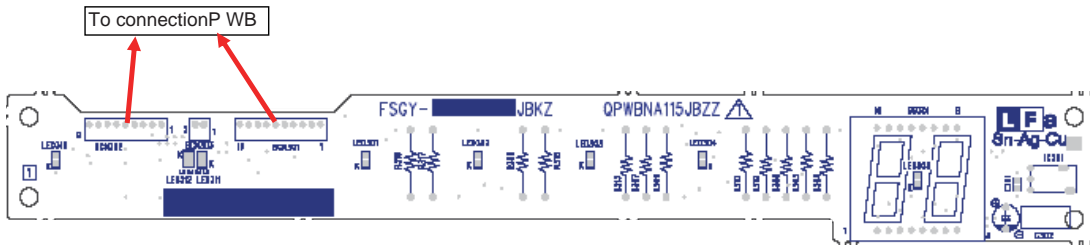

## 2. Outdoor unit

### 2.1. Electronic control circuit diagram

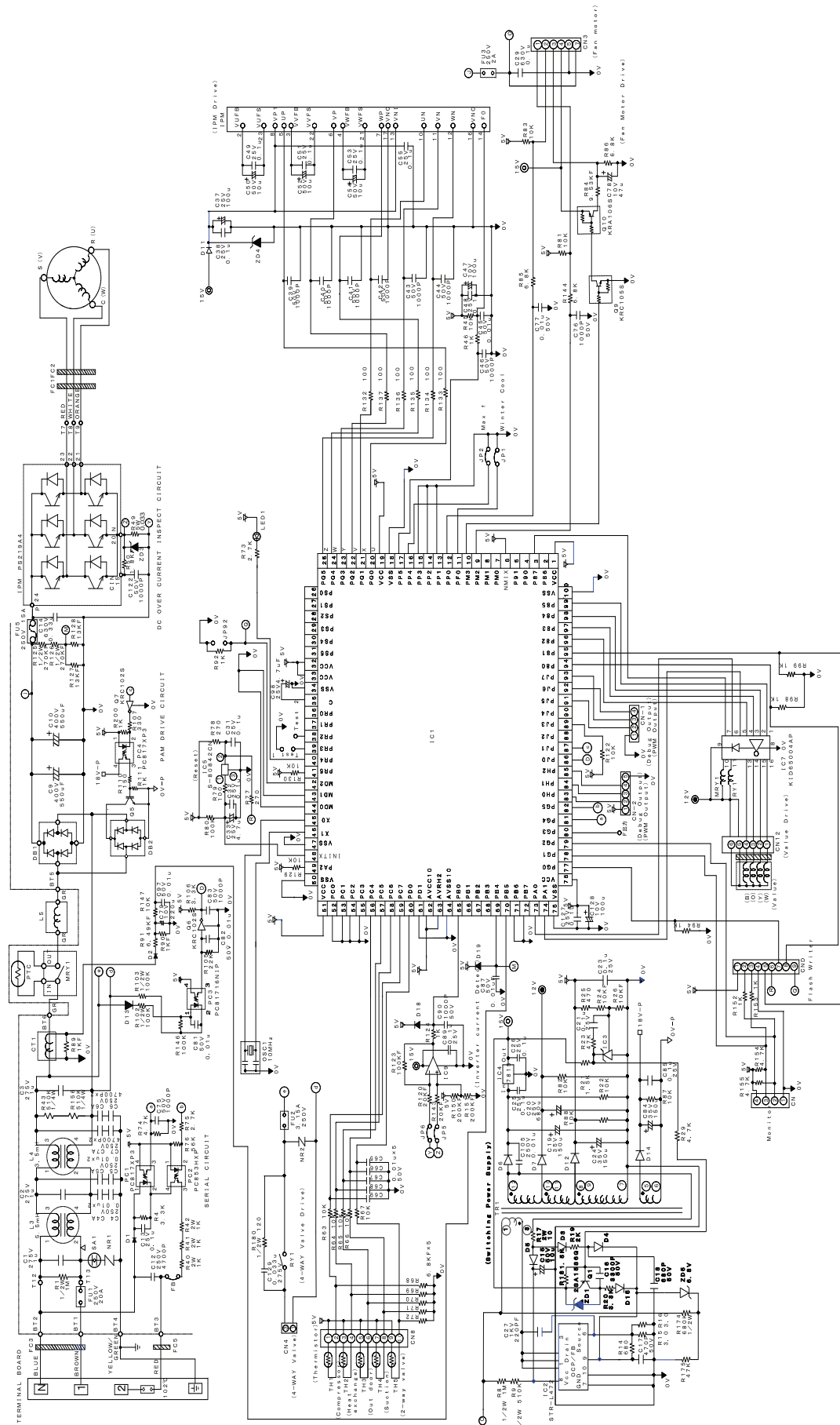

2.2. Printed wiring board

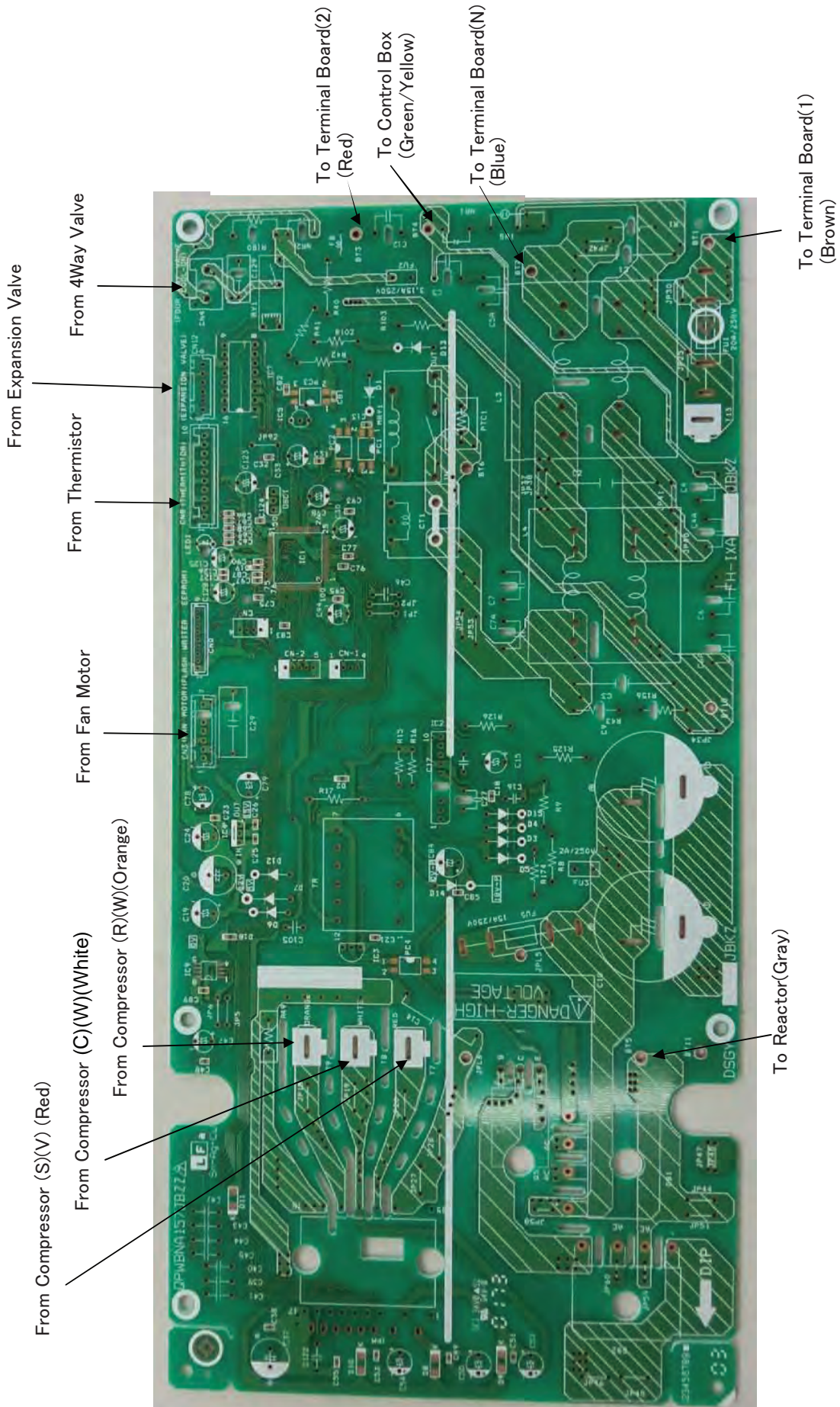

### [3] FUNCTION

#### 1. Function

##### 1.1. Restart control

Once the compressor stops operating, it will not restart for 180 seconds to protect the compressor.

Therefore, if the operating compressor is shut down from the remote control and then turned back on immediately after, the compressor will restart after a preset delay time.

(The indoor unit will restart operation immediately after the ON switch is operated on the remote control.)

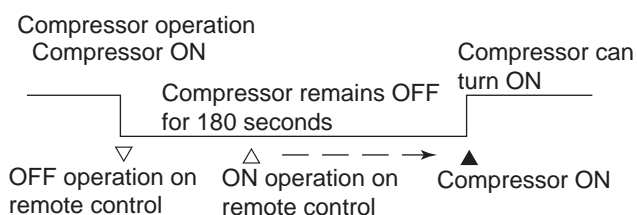

##### 1.2. Indoor unit heat exchanger freeze prevention control

If the temperature of the indoor unit heat exchanger remains below 0°C for 4 consecutive minutes during cooling or dehumidifying operation, the compressor operation stops temporarily in order to prevent freezing.

When the temperature of the indoor unit heat exchanger rises to 2°C or higher after about 180 seconds, the compressor restarts and resumes normal operation.

##### 1.3. Outdoor unit 2-way valve freeze prevention control

If the temperature of the outdoor unit 2-way valve remains below 0°C for 10 consecutive minutes during cooling or dehumidifying operation, the compressor operation stops temporarily in order to prevent freezing.

When the temperature of the 2-way valve rises to 10°C or higher after about 180 seconds, the compressor restarts and resumes normal operation.

##### 1.4. Indoor unit overheating prevention control

During heating operation, if the temperature of the indoor unit heat exchanger exceeds the indoor unit heat exchanger overheating prevention temperature (about 45 to 54°C) which is determined by the operating frequency and operating status, the operating frequency is decreased by about 4 to 15 Hz. Then, this operation is repeated every 60 seconds until the temperature of the indoor unit heat exchanger drops below the overheating protection temperature.

Once the temperature of the indoor unit heat exchanger drops below the overheating protection temperature, the operating frequency is increased by about 4 to 10 Hz every 60 seconds until the normal operation condition resumes.

If the temperature of the indoor unit heat exchanger exceeds the overheating protection temperature for 60 seconds at minimum operating frequency, the compressor stops operating and then restarts after about 180 seconds, and the above mentioned control is repeated.

##### 1.5. Outdoor unit overheating prevention control

During cooling operation, if the temperature of the outdoor unit heat exchanger exceeds the outdoor unit heat exchanger overheating prevention temperature (about 55°C), the operating frequency is decreased by about 4 to 15 Hz. Then, this operation is repeated every 60 seconds until the temperature of the outdoor unit heat exchanger drops to about 54°C or lower.

Once the temperature of the outdoor unit heat exchanger drops to about 54°C or lower, the operating frequency is increased by about 4 to 10 Hz every 60 seconds until the normal operation condition resumes.

If the temperature of the outdoor unit heat exchanger exceeds the outdoor unit heat exchanger overheating protection temperature for (120 sec: outdoor temperature  $\geq 40^\circ\text{C}$  · 60 sec : outdoor temperature  $< 40^\circ\text{C}$ ) at minimum operating frequency, the compressor stops operating and then restarts after about 180 seconds, and the above mentioned control is repeated.

##### 1.6. Compressor overheating prevention control

If the temperature of the compressor exceeds the compressor overheating prevention temperature (110°C), the operation frequency is decreased by about 4 to 10 Hz. Then, this operation is repeated every 60 seconds until the temperature of the compressor drops below the overheating protection temperature (100°C).

Once the temperature of the compressor drops below the overheating protection temperature, the operating frequency is increased by about 4 to 10 Hz every 60 seconds until the normal operation condition resumes.

If the temperature of the compressor exceeds the overheating protection temperature (for 120 seconds in cooling operation or 60 seconds in heating operation) at minimum operating frequency, the compressor stops operating and then restarts after about 180 seconds, and the above mentioned control is repeated.

##### 1.7. Startup control

When the air to air heat pump starts in the cooling or heating mode, if the room temperature is 2°C higher than the set temperature (in cooling operation) or 3.5°C lower (in heating operation), the air to air heat pump operates with the operating frequency at maximum. Then, when the set temperature is reached, the air to air heat pump operates at the operating frequency determined by fuzzy logic calculation, then enters the normal control mode after a while.

##### 1.8. Peak control

If the current flowing in the air to air heat pump exceeds the peak control current the operation frequency is decreased until the current value drops below the peak control current regardless of the frequency control demand issued from the indoor unit based on the room temperature.

##### 1.9. Outdoor unit fan delay control

The compressor stops immediately after cooling, dehumidifying or heating operation is shut down, but the outdoor unit fan continues operation for 50 seconds before it stops.

##### 1.10. Defrosting

###### 1.10.1 Reverse defrosting

The defrost operation starts when the compressor operating time exceeds 20 minutes during heating operation, as shown below, and the outside air temperature and the outdoor unit heat exchanger temperature meet certain conditions. When the defrost operation starts, the indoor unit fan stops. The defrost operation stops when the outdoor unit heat exchanger temperature rises to about 13°C or higher or the defrosting time exceeds 10 minutes.

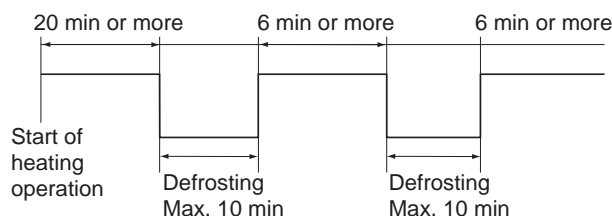

## 12PHR-N

### 1.11. ON timer

The ON timer can be activated by pressing the ON timer button. When the ON timer is activated, the operation start time is adjusted based on fuzzy logic calculations 1 hour before the set time so that the room temperature reaches the set temperature at the set time.

### 1.12. OFF timer

The OFF timer can be activated by pressing the OFF timer button. When the OFF timer is set, the operation stops after the set time.

When this timer is set, the compressor operating frequency lowers for quieter operation, and the room temperature is gradually varied after one hour (reduced 1°C three times (max. 3°C) in heating, or increased 0.3°C three times (max. 1°C) in cooling or dehumidifying operation) so that the room temperature remains suitable for comfortable sleeping.

#### Heating operation

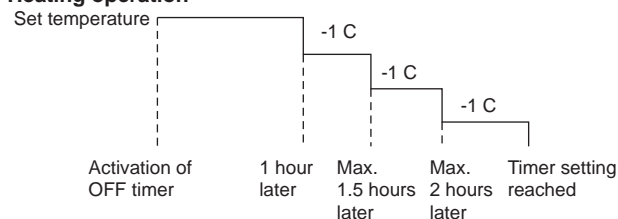

#### Cooling/dehumidifying operation

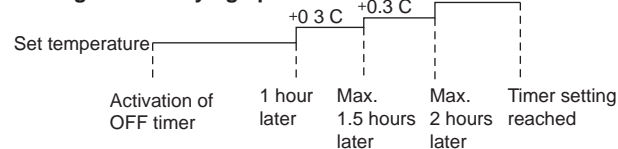

### 1.13. Power ON start

If a jumper cable is inserted in the location marked with HAJP on the indoor unit control printed circuit board (control PCB), connecting the power cord to an AC outlet starts the air to air heat pump in either cooling or heating mode, which is determined automatically by the room temperature sensor.

When a circuit breaker is used to control the ON/OFF operation, please insert a jumper as described above.

### 1.14. Self-diagnostic malfunction code display

#### 1.14.1 Indoor unit

1) When a malfunction is confirmed, a flashing malfunction code number is displayed to indicate the type of malfunction.

When the air to air heat pump is in non-operating condition, holding down AUX button for more than 5 seconds activates the malfunction code display function.

The operation continues only in the case of a serial open-circuit.

In the case of a serial short-circuit, the air to air heat pump continues operating without a malfunction code display.

2) The content of self-diagnosis (malfunction mode) is indicated by a flashing number.

(For details, refer to the troubleshooting section.)

#### 1.14.2 Outdoor unit

If a malfunction occurs, LED1 on the outdoor unit flashes in 0.2-second intervals as shown below.

#### (Example) Compressor high temperature abnormality

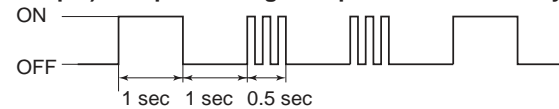

#### 1.15. Information about auto mode

In the AUTO mode, the temperature setting and mode are automatically selected according to the room temperature and outdoor temperature when the unit is turned on.

#### Modes and Temperature Settings

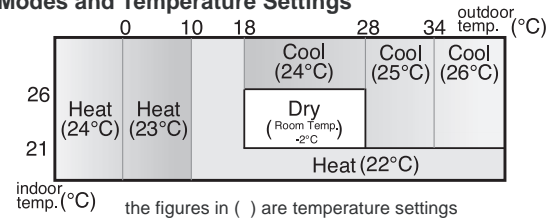

During operation, if the outdoor temperature changes, the temperature settings will automatically slide as shown in the chart.



1.16. Adjusting the air flow direction

1.16.1 Vertical air flow direction

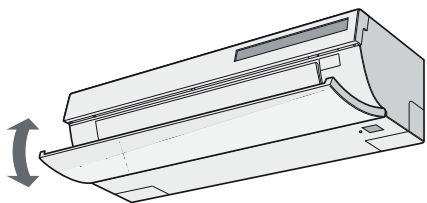

1 Press the VERTICAL AIR FLOW button to set the desired air flow direction.

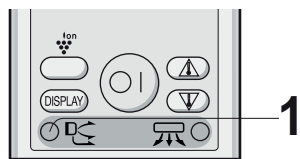

**AUTO mode**

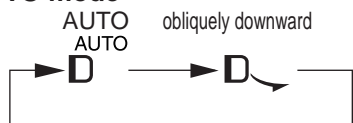

**HEAT mode**

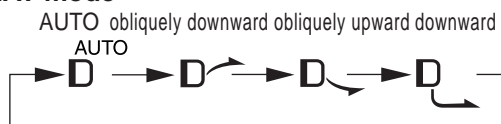

**COOL/DRY mode**

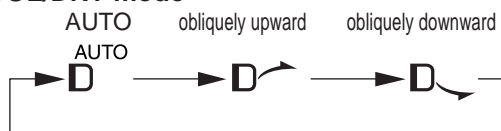

1.16.2 Horizontal air flow direction

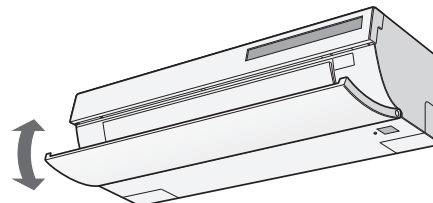

1 Press the HORIZONTAL AIR FLOW button to set the desired air flow direction.

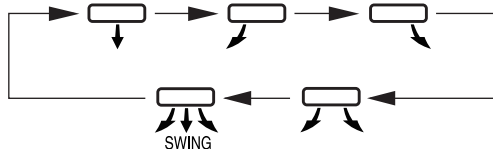
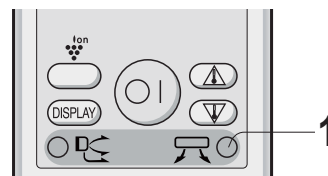

**CAUTION:**

Never attempt to adjust the open panel and the louvres manually.  
 • Manual adjustment of the open panel and the louvres can cause the unit to malfunction.

**TIPS ABOUT AIR FLOW DIRECTION “AUTO”**

**COOL mode**

The open panel will be set obliquely downward for 10 minutes, and then shift to obliquely upward to deliver cool air to the ceiling.

**HEAT mode**

The open panel will be set obliquely backward when outlet air temperature is low, and then shift to obliquely downward when outlet air becomes warm.

**DRY mode**

The open panel will be set obliquely upward.

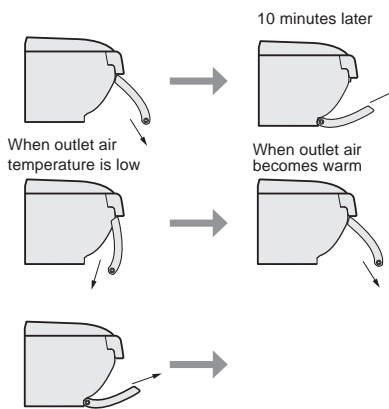

1.17. Difference of operation in Auto and Manual modes

In the Auto mode, the temperature setting is automatically determined based on the outside air temperature. In addition, the air to air heat pump operation differs from the operation in the Manual mode as explained below.

1.17.1 Difference relating to set temperature

	Auto mode			Manual mode		
	Cooling	Heating	Dehumidifying	Cooling	Heating	Dehumidifying
Temperature setting method	Automatic temperature setting based on outside air temperature. Can be changed within $\pm 2^{\circ}\text{C}$ using remote control.			Can be changed between 18 and 32 $^{\circ}\text{C}$ using remote control	Can be changed between 18 and 32 $^{\circ}\text{C}$ using remote control.	Automatic setting. Can be changed within $\pm 2^{\circ}\text{C}$ .

**1.18. Dehumidifying operation control**

If the room temperature is 26°C or higher when dehumidifying operation starts, the dehumidifying operation provides a low cooling effect in accordance with the room temperature setting automatically determined based on the outside air operation. (The setting value is the same as the set temperature for cooling operation in the auto mode.)

If the room temperature is lower than 26°C when dehumidifying operation starts, the dehumidifying operation minimizes the lowering of the room temperature.

**1.19. Self Clean operation**

Heating or Fan operation and Cluster operation are performed simultaneously.

Whether start Heating or Fan operation is determined by the outside air temperature at 3 minutes after the start of self cleaning.

The operation stops after 40 minutes. (The air to air heat pump shows the remaining minutes: 40 → 39 → 38 ... 3 → 2 → 1)

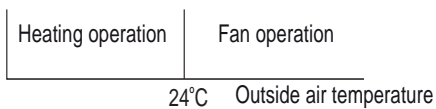

**1.20. Plasmacluster Ion function**

The Plasmacluster Ion generator inside the air conditioner will release positive and negative plasmacluster ions into the room. Approximately the same numbers of positive and negative ions released into the air will reduce some airborne mold.

During operation, press the PLASMACLUSTER button.

- The remote control will display "ion".
- The blue PLASMACLUSTER lamp on the unit will light up.

TO CANCEL

Press the PLASMACLUSTER button again.

- The PLASMACLUSTER lamp on the unit will turn off.

NOTE:

- Use of the PLASMACLUSTER operation will be memorized, and it will be activated the next time you turn on the air conditioner.
- To turn off the PLASMACLUSTER lamp, press the DISPLAY button.
- To perform the PLASMACLUSTER operation in FAN only mode, press the PLASMACLUSTER button while the unit is not operating. The mode symbol of the remote control will go off and the fan speed can not be set to AUTO.

**1.21. Winter cool**

Cooling operation is available during the winter season by the built in winter cool function.

Lower limit of outdoor temperature range is -10°C DB.

When the outside air temperature is low, the outdoor unit fan operates at slower speed.

NOTE:

Built-in protect device may work when outdoor temperature falls below 21°C DB., depending on conditions.

**1.22. 10°C OPERATION**

Heating operation with 10°C set temperature will be performed.

- 1) Press the MODE button of Remote controller and select HEAT mode.
- 2) Press the ON / OFF button to start HEAT operation.
- 3) Press the 10°C button.
  - The remote control will display 10°C.

TO CANCEL

Press the 10°C button again.

- 10°C operation will also be cancelled when the operation mode is changed, or when the unit is turned off.

NOTE:

- 10°C operation will not be available with heating operation automatically selected by AUTO mode.

**1.23. Auto restart**

When power failure occurs, after power is recovered, the unit will automatically restart in the same setting which were active before the power failure.

**1.23.1 Operating mode (Cool, Heat, Dry)**

- Temperature adjustment (within 2°C range) automatic operation
- Temperature setting
- Fan setting
- Air flow direction
- Power ON/OFF
- Automatic operation mode setting
- Swing louvre
- Plasmacluster mode

**1.23.2 Setting not memorized**

- Timer setting
- Full power setting
- Self clean

**1.23.3 Disabling auto restart function**

By removing (cutting) jumper 8 (JP8) on the printed circuit board (PCB), the auto restart function can be disabled.

**1.24 Heat only mode**

Cut the JPW jumper when you want heat only mode.  
 cool/heat mode JPW connected  
 heat only mode JPW cut

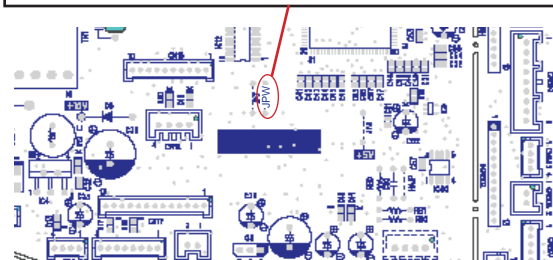

## 2. Explanation of Plasmacluster circuit

The cluster unit generates cluster ions, which are circulated throughout the room by the air flow created by the blower fan(indoor unit fan) in the air to air heat pump unit.

1)When microcomputer output turns "H", the Q11 output changes to "Lo", turning ON the cluster unit for the generation of cluster ions (positive and negative ions).

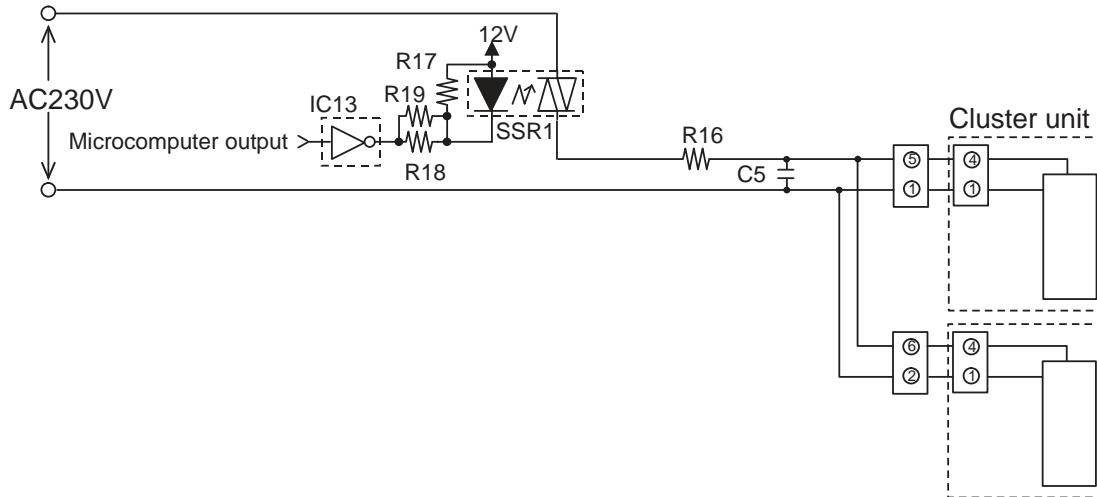

## 3. Outline of PAM circuit

### 3.1. PAM (Pulse Amplitude Modulation)

The PAM circuit varies the compressor drive voltage and controls the rotation speed of the compressor.

The IGBT shown in the block diagram charges the energy (electromotive force) generated by the reactor to the electrolytic capacitor for the inverter by turning ON and OFF.

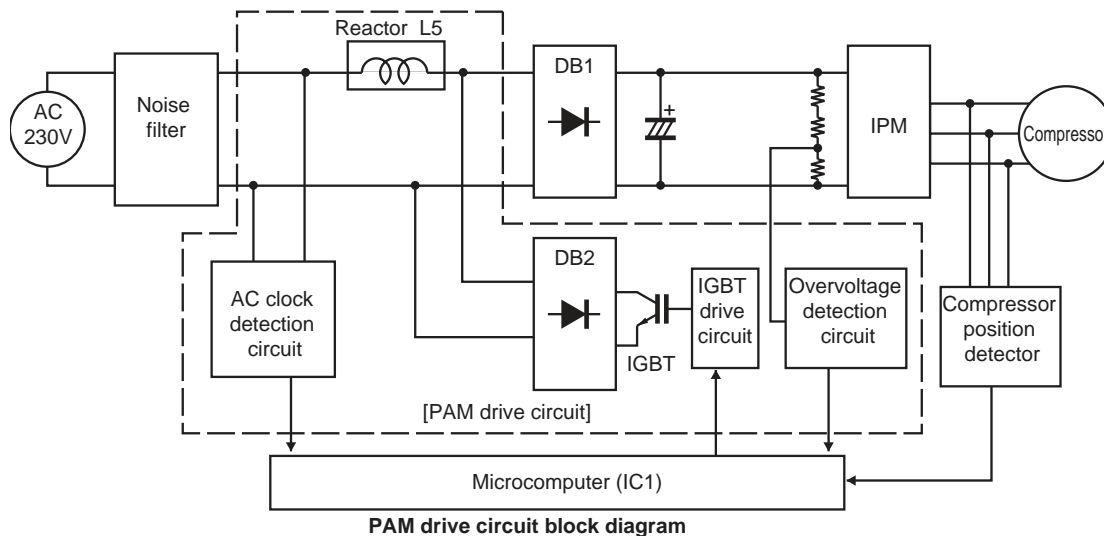

When the IGBT is ON, an electric current flows to the IGBT via the reactor (L1) and diode bridge (DB2).

When the IGBT turns OFF, the energy stored while the IGBT was ON is charged to the voltage capacitor via the diode bridge (DB1).

As such, by varying the ON/OFF duty of the IGBT, the output voltage is varied.

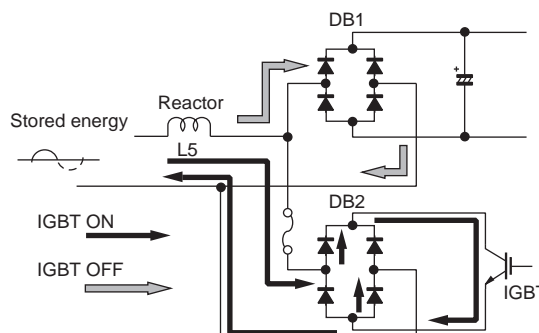

**3.2. High power factor control circuit**

This circuit brings the operating current waveform closer to the waveform of commercial power supply voltage to maintain a high power factor. Because of the capacitor input, when the PAM circuit is OFF, the phase of the current waveform deviates from the voltage waveform as shown below.

To prevent this deviation, a current is supplied during the periods indicated by "O" in the diagram. To determine the length of period to supply a current, the zero-cross timing of the AC input voltage is input to the microcomputer via the clock circuit. The power source frequency is also determined at the same time.

The IGBT turns ON after the time length determined by the zero-cross point to supply a current to the IGBT via the reactor. This brings the current waveform closer to the voltage waveform in phase.

As described above, the ON/OFF operation of the IGBT controls the increase/decrease of the compressor power supply voltage (DC voltage) to improve the compressor efficiency and maintain a high power factor by keeping the current phase closer to that of the supply voltage.

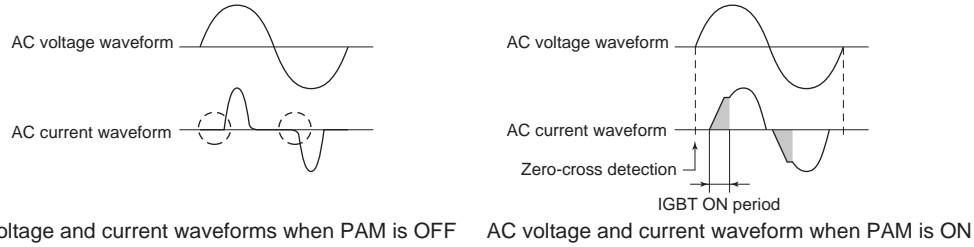

**3.2.1 Detailed explanation of PAM drive circuit sequence**

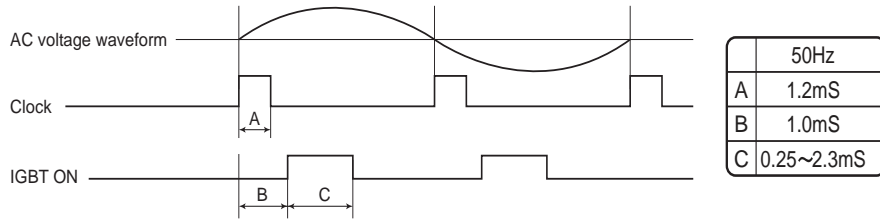

**3.2.2 AC clock (zero-cross) judgment**

- The clock circuit determines the time from one rising point of the clock waveform to the next rising point. The detected clock waveform is used to judge the power source frequency (50Hz).
- The zero-cross of the AC voltage is judged as the rising of the clock waveform, as shown in the diagram above.

**3.2.3 IGBT ON start time (delay time B)**

- Based on the zero-cross of the AC voltage, the IGBT turns ON after a delay time set according to the power source frequency.

**3.2.4 IGBT ON time (C)**

- After the above delay time, the IGBT turns ON to supply a current to the reactor.
- The ON time of the IGBT determines the amount of energy (level of DC voltage rise) supplied to the reactor. DC voltage level in each operation mode (varies depending on external load conditions)
  - Cooling operation --- 220 to 290 V

### 3.3. PAM protection circuit

To prevent excessive voltage of PAM output from damaging the IPM and electrolytic capacitor as well as the control printed circuit board (PCB), this circuit monitors the PAM output voltage and turns off the PAM control signal and PAM drive immediately when an abnormal voltage output is generated. At the same time, it shuts off the compressor operation.

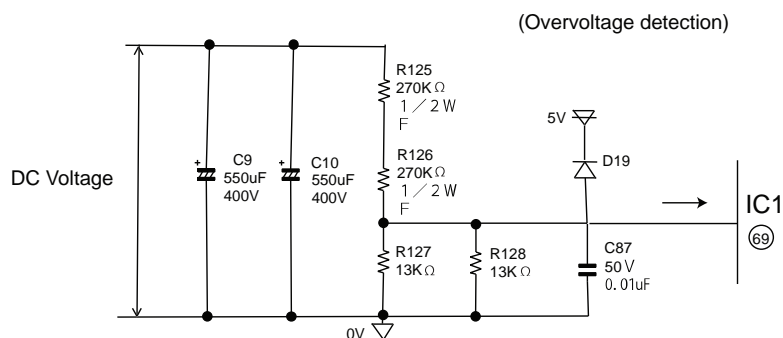

The protection voltage level is as follows.

#### 3.3.1 Details of troubleshooting procedure for PAM

##### 1) PAM shutdown due to error

1) When the DC voltage detection circuit sends a signal exceeding the specified voltage to the microcomputer

DC voltage of 400 V or higher

– When an error is detected

- PAM IGBT turns OFF.
- Compressor turns OFF.
- All units shut down completely when the error occurs four times.

2) When the outdoor unit clock waveform differs from the specified value immediately before the PAM IGBT turns ON

When there is no clock waveform input.

When a clock signal of other than specified power source frequency (50 Hz) is input

– When an error is detected

- PAM IGBT does not turn ON
- Compressor operates normally.
- Complete shutdown does not occur.

##### 2) PAM error indication

In case of error “1)”

– An error signal is sent to the indoor unit as soon as an error is generated.

- Malfunction No. 14-0 is indicated when the error code is called out by the indoor unit's self-diagnosis function.

– The LED on the outdoor unit flashes 14 times when an error is generated.

- The LED continues flashing in the 14-time cycle even after the compressor stops operating.
- The LED turns off (data is deleted from the memory) when the outdoor unit power is turned off.

In case of error “2)”

– An error signal is sent to the indoor unit as soon as an error is judged.

- Malfunction No. 14-1 is indicated when the error code is called out by the indoor unit's self-diagnosis function.

– The LED on the outdoor unit flashes 14 times when an error is judged.

- The LED on the outdoor unit flashes in normal pattern when the compressor stops operating.  
(Compressor OFF or Thermostat OFF from remote control)

\* When a user complains that the air conditioner does not provide sufficient cool air or warm air

In addition to conventional error-generating reasons, there is a possibility that the PAM IGBT does not turn ON even if the compressor is operating.

In that case, the DC voltage does not rise even though the compressor is operating, and lowers to the 180-VDC level.

– Check items

- Clock circuit check
- PAM IGBT check
- Fuse (Fu6) open-circuit check

**4. Explanation of IPM drive circuit**

The IPM for compressor drive is made by Mitsubishi Electric.

The power supply for the IPM drive, the shunt resistance for over current detection, etc., are provided outside the IPM (control PCB).

**4.1. IPM drive power supply circuit**

The power supply for the upper-phase IGBT (HU, HV, HW) drive employs a bootstrap system, and provides power to the upper-phase IC.

The 15-V power supply for the lower-phase IC is provided by the control printed circuit board (PCB).

**4.1.1 Brief explanation of bootstrap system (single power drive system)**

To supply power to the upper-phase IC, the microcomputer (IC1) turns ON the lower-phase IGBT (LU, LV, LW).

This results in a charging current that flows to the electrolytic capacitor of each upper-phase IC input and charges the bootstrap capacitor with a 15V current.

The power supply for the subsequent stages is charged while the lower-phase IGBT is ON in ordinary compressor drive control.

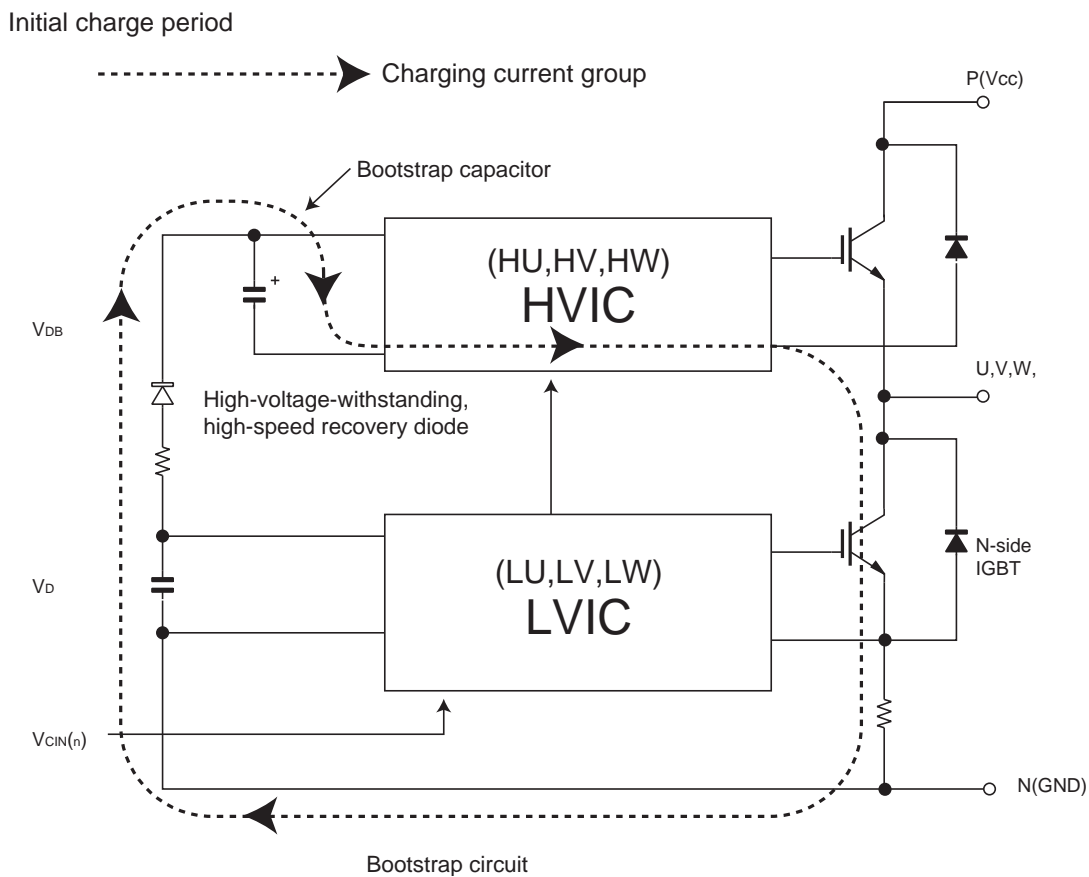

4.1.2 DC over current detection circuit

When a current of about 25 A or higher flows through the shunt resistance (R49) on the control printed circuit board (PCB), the voltage at this resistance is input to IPM CIN pin (15). Then, the gate voltage of the lower-phase IGBT (LU, LV, LW) inside the IPM turns OFF to cut off the overcurrent. At the same time, an L output of more than 20μs is generated from IPM Fo pin (14), and this results in an L input to over current detection input pin (34) of the microcomputer (IC1) and turns OFF the PWM signal output (IC1 pins (51) through (56)) to the IGBT gate.

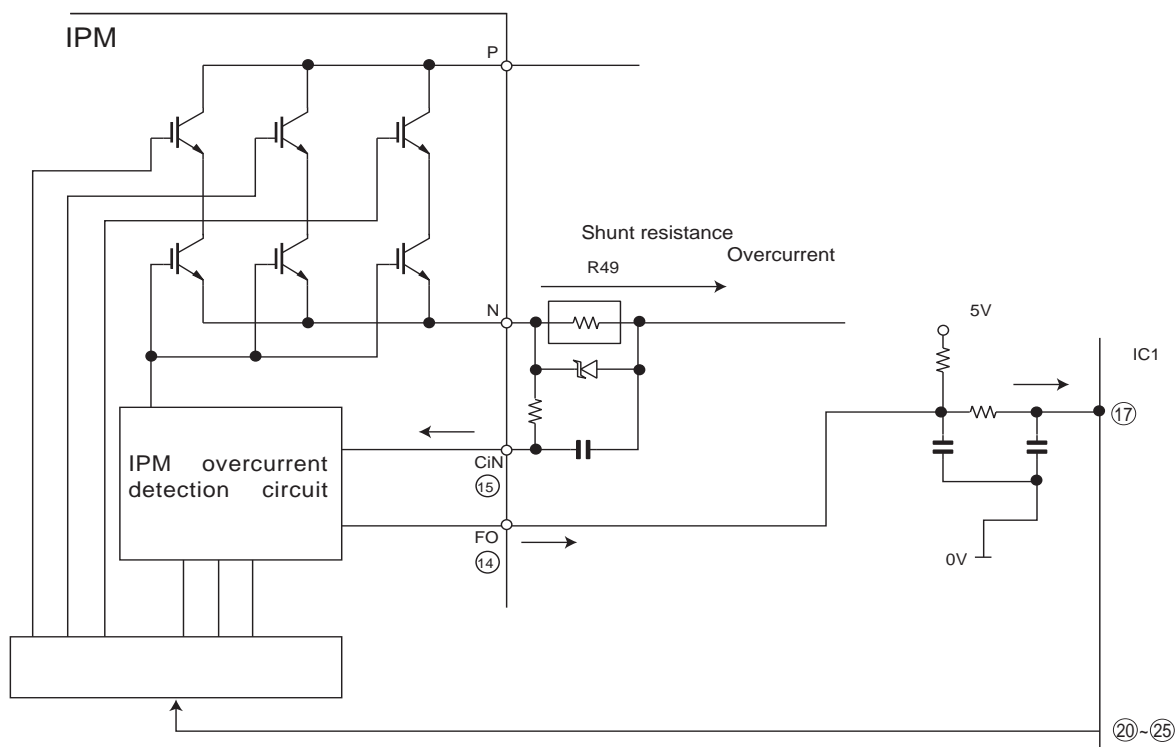
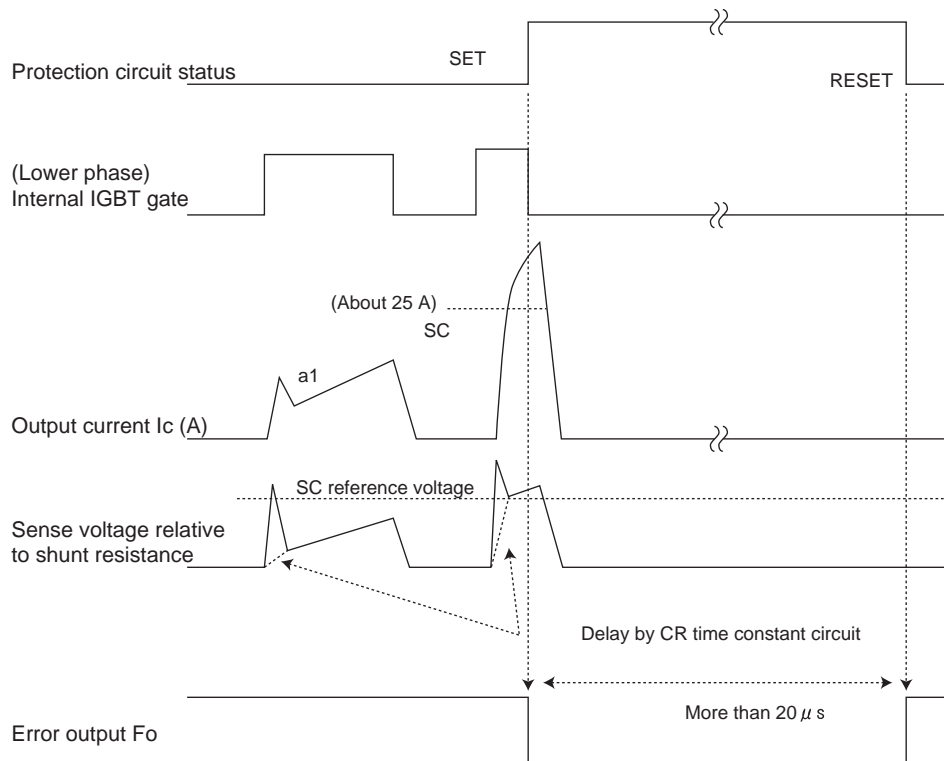

**5. 120° Energizing control (digital position detection control)**

This control system detects the digital position detection signal and adjusts the rate of acceleration/deceleration accordingly.

The motor's induced voltage waveform is input to the comparator in the form of PWM-switched pulse waveform, and a position detection signal is generated as a reference voltage equaling 1/2 of 280 VDC. However, since there is no induced voltage waveform when the PWM waveform is OFF, the microcomputer performs internal processing so that detection is enabled only when it is ON. Based on the detected position signal, actual PWM waveform output timing is determined. Since it does not use a filter circuit, the detection accuracy is high. The microcomputer performs internal processing to cancel spike voltage during the regenerative process.

Furthermore, even if the induced voltage is low, position detection is still possible, thus allowing sensor-less operation at low rotation speed in the initial stage of operation. This reduces the starting current and improves the IPM reliability.

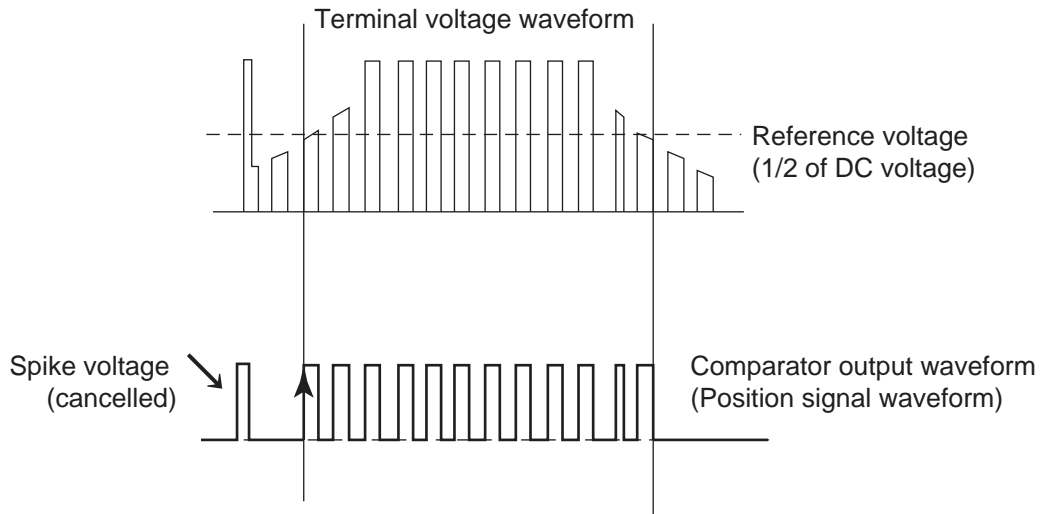

**6. 180° Energizing control**

This is the control system to moderate the speed by the current phase difference for higher efficiency and lower noise of the compressor. The current phase difference control is the control system paid attention to the interrelation between efficiency and phase gap generated by the applied voltage of motor and current in the coil of motor as shown in the figure below.

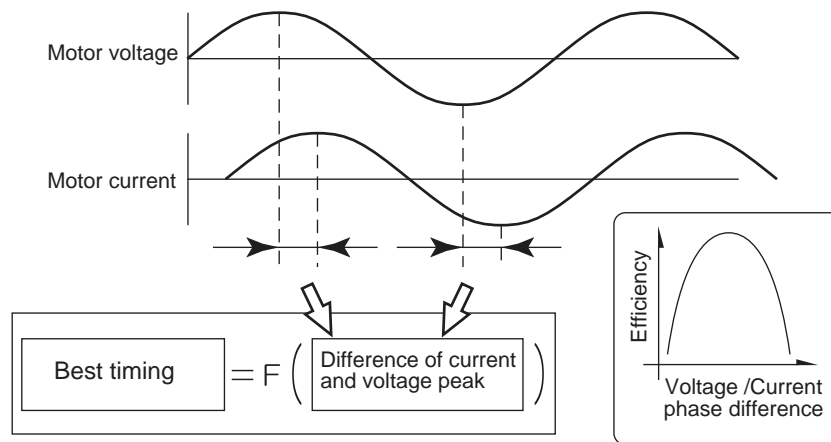

Concept chart of the current phase difference control

This control is the V/F drive system independent of the location of rotor, detecting the phase difference between driving voltage phase and line current phase flowing in motor coil, and controls the modulation rate data to get the phase difference at the best effici



## CHAPTER 3. FUNCTION AND OPERATION OF PROTECTIVE PROCEDURES

### [1] PROTECTION DEVICE FUNCTIONS AND OPERATIONS

Function		Operation				Self-diagnosis result display	
		Description	Detection period	Reset condition	Indoor unit error display	Indoor unit	Outdoor unit
1	Indoor unit fan lock	Operation stops if there is no input of rotation pulse signal from indoor unit fan motor for 1 minute.	When indoor unit fan is in operation	Operation OFF or ON	☆ 1	Yes	None
	Indoor unit fan rotation speed error	Operation stops if rotation pulse signal from indoor unit fan indicates abnormally low speed (about 300 rpm or slower).	When indoor unit fan is in operation	Operation OFF or ON	☆ 1	Yes	None
2	Indoor unit freeze prevention	Compressor stops if temperature of indoor heat exchange pipe thermistor remains below 0°C for 4 minutes.	When in cooling or dehumidifying operation	Automatic reset when heat exchanger temperature rises above freeze prevention temperature(2°C or higher)	—	None	None
3	2-way valve freeze prevention	Compressor stops if temperature of outdoor unit 2-way valve remains below 0°C for 10 continuous minutes during cooling or dehumidifying operation.	When in cooling or dehumidifying operation	Automatic reset when temperature of 2-way valve rises above 10°C.	None	Yes	Yes
4	Indoor unit heat exchanger overheat shutdown	Operation frequency lowers if indoor unit heat exchanger temperature exceeds overheat temperature during heating operation. Compressor stops if indoor unit heat exchanger temperature exceeds overheat temperature for 60 seconds at minimum frequency. Overheat temperature setting value indoor unit heat exchanger thermistor temperature: about 45 to 54°C	When in heating operation	Automatic reset after safety period (180 sec).	None	Yes	Yes
5	Outdoor unit heat exchanger overheat shutdown	Operating frequency lowers if temperature of compressor chamber thermistor (TH1) falls below about 110°C. Compressor stops if temperature of compressor chamber thermistor (TH1) remains at about 110°C (for 120 seconds in cooling operation, or 60 seconds in heating operation) at minimum frequency.	When in cooling or dehumidifying operation	Automatic reset after safety period (180 sec).	None	Yes	Yes
6	Compressor discharge overheat shutdown	Operating frequency lowers if temperature of compressor chamber thermistor (TH1) falls below about 110°C. Compressor stops if temperature of compressor chamber thermistor (TH1) remains at about 110°C (for 120 seconds in cooling operation, or 60 seconds in heating operation) at minimum frequency.	When compressor is in operation	Automatic reset after safety period (180 sec).	None	Yes	Yes
7	Dehumidifying operation temporary stop	Compressor stops if outside air temperature thermistor is lower than about 16°C during dehumidifying operation.	When in dehumidifying operation	Automatic reset when outside air temperature rises above 16°C.	None	Yes	Yes

Function		Operation				Self-diagnosis result display	
		Description	Detection period	Reset condition	Indoor unit error display	Indoor unit	Outdoor unit
8	DC overcurrent error	Compressor stops if DC current of about 25 A or higher flows in IPM.	When compressor is in operation	Operation OFF or ON	Yes ☆ 1	Yes	Yes
9	AC over current error	Operating frequency lowers if outdoor AC current exceeds peak control current value. Outdoor stops if compressor AC current exceeds peak control current value at minimum frequency.	When compressor is in operation	Operation OFF or ON	Yes ☆ 1	Yes	Yes
10	AC overcurrent error in compressor OFF status	Indoor and outdoor units stop if outdoor AC current exceeds about 3 A while compressor is in non-operation status.	When compressor is in non-operation	Replacement of defective parts such as IPM	Yes ☆ 2	Yes	Yes
11	AC maximum current error	Compressor stops if outdoor AC current exceeds 17 A.	When compressor is in operation	Operation OFF or ON	Yes ☆ 1	Yes	Yes
12	AC current deficiency error	Compressor stops if operating frequency is 50 Hz or higher and outdoor AC current is about 2.0 A or lower.	When compressor is in operation	Operation OFF or ON	Yes ☆ 1	Yes	Yes
13	Thermistor installation error or 4-way valve error	Compressor stops if high and low values of temperatures detected by outdoor unit heat exchanger thermistor (TH2) and 2-way valve thermistor (TH5) does not match operating cycle.	3 minutes after compressor startup	Operation OFF or ON	Yes ☆ 2	Yes	Yes
14	Compressor high temperature error	Compressor stops if compressor chamber thermistor (TH1) exceeds about 114°C, or if there is short-circuit in TH1.	When in operation	Operation OFF or ON	Yes ☆ 1	Yes	Yes
15	Outdoor unit heat exchanger thermistor short-circuit error	Compressor stops if there is short-circuit in outdoor unit heat exchanger thermistor (TH2).	At compressor startup	Operation OFF or ON	Yes ☆ 1	Yes	Yes
16	Outdoor unit outside air temperature thermistor short-circuit error	Compressor stops if there is short-circuit in outdoor unit outside air temperature thermistor (TH3).	At compressor startup	Operation OFF or ON	Yes ☆ 1	Yes	Yes
17	Outdoor unit suction thermistor short-circuit error	Compressor stops if there is short-circuit in outdoor unit suction thermistor (TH4).	At compressor startup	Operation OFF or ON	Yes ☆ 1	Yes	Yes
18	Outdoor unit 2-way valve thermistor short-circuit error	Compressor stops if there is short-circuit in outdoor unit 2-way valve thermistor (TH5).	At compressor startup	Operation OFF or ON	Yes ☆ 1	Yes	Yes
19	Outdoor unit heat exchanger thermistor open-circuit error	Compressor stops if there is open-circuit in outdoor unit heat exchanger thermistor (TH2).	At compressor startup	Operation OFF or ON	Yes ☆ 1	Yes	Yes
20	Outdoor unit suction thermistor open-circuit error	Compressor stops if there is open-circuit in outdoor unit outside air temperature thermistor (TH3).	At compressor startup	Operation OFF or ON	Yes ☆ 1	Yes	Yes
21	Outdoor unit suction thermistor open-circuit error	Compressor stops if there is open-circuit in outdoor unit suction thermistor (TH4).	At compressor startup	Operation OFF or ON	Yes ☆ 1	Yes	Yes
22	Outdoor unit 2-way	Compressor stops if there is open-circuit in outdoor unit 2-way valve thermistor (TH5).	At compressor startup	Operation OFF or ON	Yes ☆ 1	Yes	Yes

Function		Operation				Self-diagnosis result display	
		Description	Detection period	Reset condition	Indoor unit error display	Indoor unit	Outdoor unit
23	Outdoor unit discharge thermistor open-circuit error	Compressor stops if there is open-circuit in outdoor unit discharge thermistor (TH1).	At compressor startup	Operation OFF or ON	Yes ☆ 1	Yes	Yes
24	Serial signal error	Compressor stops if outdoor unit cannot receive serial signal from indoor unit for 30 seconds.	When in operation	Reset after reception of serial signal	None	None	None
25	Compressor startup error	Compressor stops if compressor	At compressor startup	Operation OFF or ON	Yes ☆ 3	Yes	Yes
26	Compressor rotation error (at 120° energizing)	Compressor stops if there is no input of position detection signal from compressor or input is abnormal.	Compressor operating at 120° energizing	Operation OFF or ON	Yes ☆ 3	Yes	Yes
27	Outdoor unit DC fan error	Operation stops if there is no input of rotation pulse signal from outdoor unit fan motor for 30 seconds.	When outdoor unit fan is in operation	Operation OFF or ON	Yes ☆ 1	Yes	Yes
28	PAM over voltage error	Compressor stops if DC voltage is 400 V or higher.	When in operation	Operation OFF or ON	Yes ☆ 2	Yes	Yes
29	PAM clock error	When power source frequency cannot be determined (at startup), or when power source clock cannot be detected for 1 continuous second (at startup).	At compressor startup, when in operation	Compressor continues operation without stopping.	None	Yes	Yes

☆ 1—A single error judgment results in the display of the indoor unit error (complete shutdown).

☆ 2—The outdoor unit restarts four times before the indoor unit error is displayed (complete shutdown).

☆ 3—The outdoor unit restarts eight times before the indoor unit error is displayed (complete shutdown).

## [2] AIR CONDITIONER OPERATION IN THERMISTOR ERROR

### 1. Indoor unit

Item	Mode	Control operation	When resistance is low (temperature judged higher than actual)	Short-circuit	When resistance is high (temperature judged lower than actual)	Open-circuit
Room temperature thermistor (TH1)	Auto	Operation mode judgment	Cooling mode is activated even if room temperature is low.	Cooling mode is activated in most cases.	Heating mode is activated even if room temperature is high.	Heating mode is always activated.
	Cooling	Frequency control	Room becomes too cold.	Air conditioner operates in full power even when set temperature is reached.	Room does not become cool.	Compressor does not operate.
	Dehumidifying	Room temperature memory Frequency control	Normal operation.	Room temperature is stored in memory as 31.0°C, and compressor does not stop.	Normal operation.	Room temperature is stored in memory as 18.5°C, and compressor does not operate.
	Heating	Frequency control	Room does not become warm.	Frequency does not increase above 30 Hz (40 Hz).	Room becomes too warm.	AIR CONDITIONER operates in full power even when set temperature is reached.
Heat exchanger thermistor (TH2)	Cooling Dehumidifying	Freeze prevention	Indoor unit evaporator may freeze.	Indoor unit evaporator may freeze.	Compressor stops occasionally.	Compressor does not operate.

## 2. Outdoor unit

Item	Mode	Control operation	When resistance is low (temperature judged higher than actual)	Short-circuit	When resistance is high (temperature judged lower than actual)	Open-circuit
Compressor chamber thermistor (TH1)	Cooling Dehumidifying Heating	Expansion valve control and compressor protection	Compressor operates, but room does not become cool or warm (expansion valve is open).	Compressor high temperature error indication.	Layer short-circuit or open-circuit may result in compressor in normal operation.	Outdoor unit thermistor open-circuit error indication.
Heat exchanger thermistor (TH2)	Cooling Dehumidifying	Outdoor unit heat exchanger overheat prevention	Compressor operates at low speed or stops.	Outdoor unit thermistor short-circuit error indication.	Normal operation.	Outdoor unit thermistor open-circuit error indication.
	Heating	Expansion valve control Defrosting	Defrosting operation is not activated as needed, and frost accumulates on outdoor unit (expansion valve is closed).	Outdoor unit thermistor short-circuit error indication.	Defrosting operation is activated unnecessarily, and room does not become warm (expansion valve is open).	Outdoor unit thermistor open-circuit error indication.
Outside air temperature thermistor (TH3)	Auto	Operation mode judgment	Cooling mode is activated even if room temperature is low.	Outdoor unit thermistor short-circuit error indication.	Heating mode is activated even if room temperature is high.	Outdoor unit thermistor open-circuit error indication.
	Cooling Dehumidifying	Operation not affected	Normal operation.	Outdoor unit thermistor short-circuit error indication.	Normal operation.	Outdoor unit thermistor open-circuit error indication.
	Heating	Rating control Defrosting	Defrosting operation is activated unnecessarily.	Outdoor unit thermistor short-circuit error indication.	Defrosting operation is not activated, and frost accumulates on outdoor unit.	Outdoor unit thermistor open-circuit error indication.
Suction pipe thermistor (TH4)	Cooling Dehumidifying	Expansion valve control	Compressor operates, but room does not become cool (expansion valve is open).	Outdoor unit thermistor short-circuit error indication.	Frost accumulates on evaporator inlet section, and room does not become cool (expansion valve is closed).	Outdoor unit thermistor open-circuit error indication.
	Heating	Expansion valve control	Compressor operates, but room does not become warm (expansion valve is open).	Outdoor unit thermistor short-circuit error indication.	Frost accumulates on expansion valve outlet section, and room does not become warm (expansion valve is closed).	Outdoor unit thermistor open-circuit error indication.
2-way valve thermistor (TH5)	Cooling Dehumidifying	Expansion valve control	Frost accumulates on indoor unit evaporator and room does not become cool (expansion valve is closed).	Outdoor unit thermistor short-circuit error indication.	Compressor operates, but room does not become cool (expansion valve is open).	Outdoor unit thermistor open-circuit error indication.
	Heating	Operation not affected	Normal operation.	Outdoor unit thermistor short-circuit error indication.	Normal operation.	Outdoor unit thermistor open-circuit error indication.

### [3] THERMISTOR TEMPERATURE CHARACTERISTICS

#### 1. Indoor unit thermistor temperature characteristics

Figure 1 Temperature properties of indoor thermistors

Thermistor	Signal	Color
Room temperature	TH1	Yellow
Heat exchange	TH2	Orange

Room temperature thermistor TH1 (CN10 ① - ③)  
Heat exchange thermistor TH2 (CN11 ① - ②)

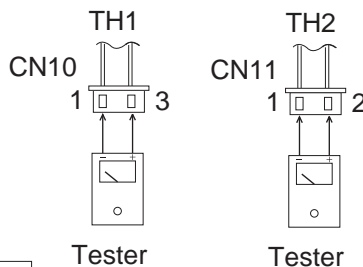
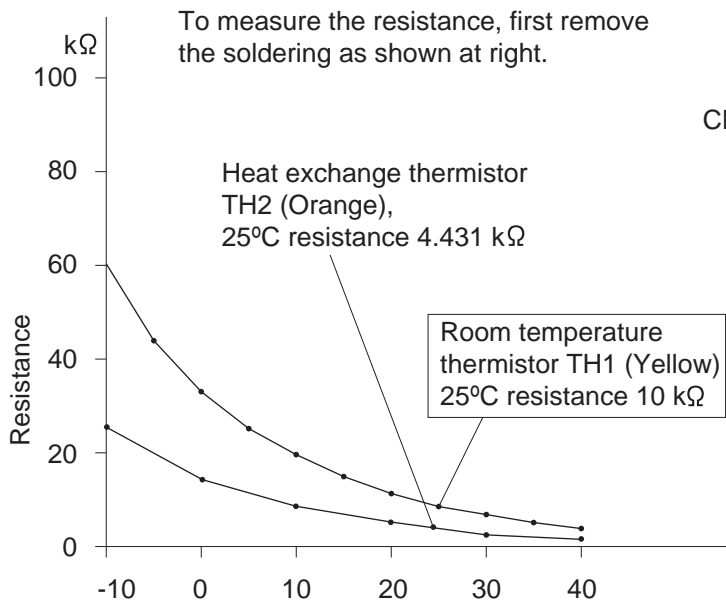

#### 2. Outdoor unit thermistor temperature characteristics

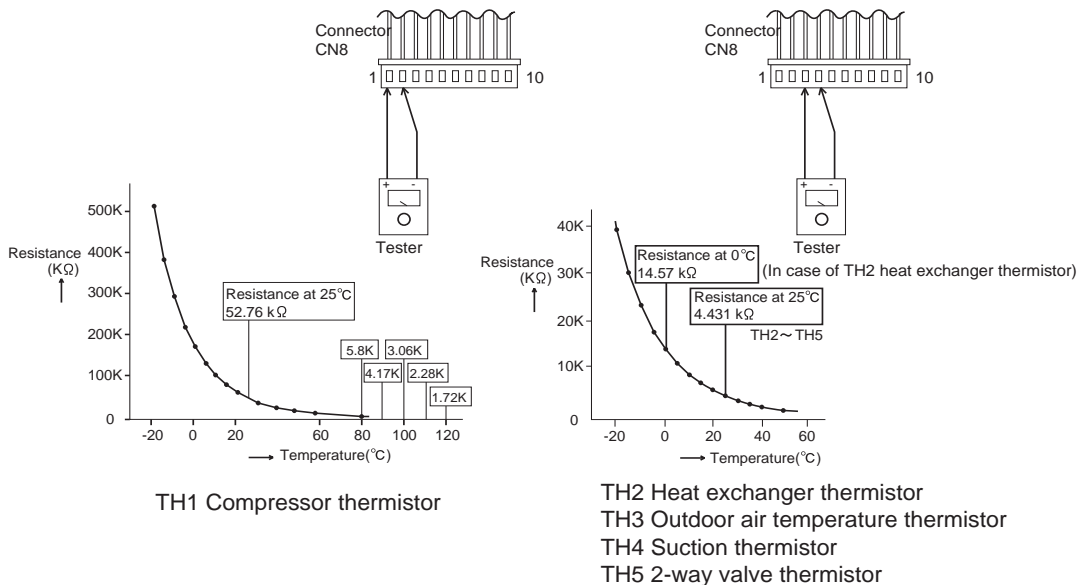

Thermistor	No.	Connector	Color
Compressor thermistor	TH1	No. (1) - No. (2)	Red
Heat exchanger thermistor	TH2	No. (3) - No. (4)	Orange
Outdoor air temperature thermistor	TH3	No. (5) - No. (6)	Green
Suction thermistor	TH4	No. (7) - No. (8)	Black
2-way valve thermistor	TH5	No. (9) - No. (10)	Yellow

Before measuring resistance, disconnect connectors from PWB.

## [4] HOW TO OPERATE THE OUTDOOR UNIT INDEPENDENTLY

### 1. Cooling in 40 Hz fixed mode

To operate the outdoor unit independently, short-circuit the sections indicated by arrows in the diagram below with an adapter, and apply 220-240 VAC between (1) and (N) on the terminal board of the outdoor unit. This allows the outdoor unit to be operated in cooling mode independently.

(Do not operate the outdoor unit in this condition for an extended period of time.)

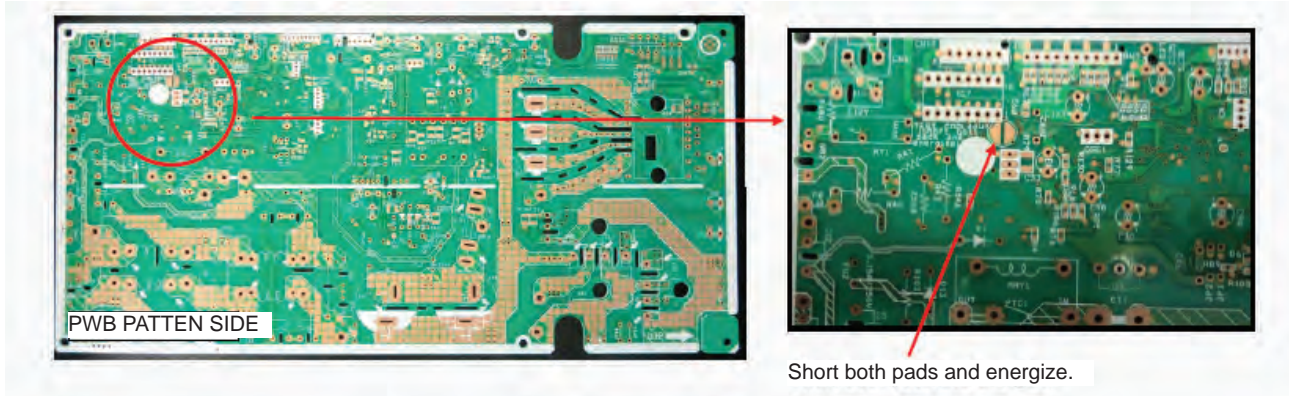

## [5] GENERAL TROUBLESHOOTING CHART

### 1. Indoor unit does not turn on

Main cause	Inspection method	Normal value/condition	Remedy
Cracked PWB. (Cracked pattern)	Check visually.	There should be no cracking in PWB or pattern.	Replace PWB.
Open-circuit in FU1 (250 V, 3.15 A).	Check melting of FU1.	There should be no open-circuit.	Replace PWB.

### 2. Indoor unit fan speed does not change

Main cause	Inspection method	Normal value/condition	Remedy
Open-circuit in heat exchanger thermistor (TH2) (in heating operation)	Measure thermistor resistance (dismount for check).	-1	Replace thermistor.
		There should be no open-circuit or faulty contact.	Replace thermistor.
Disconnected heat exchanger thermistor (TH2) (in heating operation)	Inspect connector on PWB. Check thermistor installation condition.	Thermistor should not be disconnected.	Install correctly.

### 3. Indoor unit fan speed does not change

Main cause	Inspection method	Normal value/condition	Remedy
Remote control is not designed to allow fan speed change in several operation mode.	Check operation mode.	Fan speed should change except during dehumidifying operation, ventilation, light dehumidifying operation, self clear, full power.	Explain to user.

### 4. Remote control signal is not received

Main cause	Inspection method	Normal value/condition	Remedy
Batteries at end of service life.	Measure battery voltage.	2.5 V or higher (two batteries in series connection)	Install new batteries.
Batteries installed incorrectly.	Check battery direction.	As indicated on battery compartment.	Install batteries in indicated direction.
Lighting fixture is too close, or Fluorescent lamp is flickering in the room.	Turn off light and check.	Signal should be received when light is turned off.	Change light position or install new fluorescent lamp.
Sevick light (Hitachi) is used in the room.	Check room lights.	Signal may not be received sometimes due to effect of Sevick light.	Replace light or change position.
Operating position/angle are inappropriate.	Operate within range specified in manual.	Signal should be received within range specified in manual.	Explain appropriate handling to user.
Open-circuit or short-circuit in wiring of light receiving section.	Check if wires of light receiving section are caught.	Wires of light receiving section should not have any damage caused by pinching.	Replace wires of light receiving section.

Main cause	Inspection method	Normal value/condition	Remedy
Light receiving unit is defective	Check signal receiving circuit (measure voltage between terminals 8 and 10 or 9 and 10 of connector CN17).	Tester indicator should move when signal is received.	Replace PWB.
Dew condensation on light receiving unit.	Check for water and rust.	Signal should be received within range specified in manual.	Take moisture-proof measure for lead wire outlet of light receiving section.

### 5. Louvres do not move

Main cause	Inspection method	Normal value/condition	Remedy
Caught in sliding section.	Operate to see if louvres are caught in place.	Louvres should operate smoothly.	Remove or correct catching section.
Disconnected connector (CN13, CN16, CN19) on relay PWB, louver motor side)	Inspect connectors.	Connectors or pins should not be disconnected.	Install correctly.
Contact of solder on PWB (Connector section on PWB)	Check visually.	There should not be solder contact.	Correct contacting section.

### 6. There is noise in TV/radio

Main cause	Inspection method	Normal value/condition	Remedy
Grounding wires not connected properly.	Check grounding wire connections.	Grounding wires should be connected properly.	Connect grounding wires properly.
TV/radio is placed too close to outdoor unit.	Check distance between TV/radio and outdoor unit.	If TV/radio is placed too close, it may become affected by noise.	Move TV/radio away from outdoor unit.
Other than above.	Check for radio wave interference.		

### 7. Malfunction occurs

Main cause	Inspection method	Normal value/condition	Remedy
Malfunction caused by noise.	Check for radio wave interference.		

### 8. Compressor does not start

Main cause	Inspection method	Normal value/condition	Remedy
Erroneous inter-unit connection.	Check wiring between indoor and outdoor units.	Terminal board 1-N: 220-240 VAC, 50 Hz Terminal board 2: serial signal	Correct wiring.
Damaged IPM.	Check IPM continuity.	See [IPM check method] on page 3-10	Replace IPM.
Dried-up electrolytic capacitor.	Check electrolytic capacitor.	See [Inverter electrolytic capacitor (C9,C10) check method] on page 3-9	Replace electrolytic capacitor.
Blown outdoor unit fuse. .	Check 20A fuse. Check 15A fuse.	Fuse should not be blown.	Replace fuse/diode bridge. Replace fuse. Replace outdoor unit PWB assembly
Power supply voltage is too low.	Measure power supply voltage during startup.	230±10 VAC, 50 Hz	Make sure that power supply voltage is 200 V or higher.
Compressor lock. • Temp. fuse of terminal is error • EEPROM error • AC Over current error	Supply current and touch compressor cover (sound absorbing material) to check if operation starts.  See (Diagnosis Function and display mode) on page 3-13	Compressor should start normally.  Malfunction display section (0-0) Compressor should start normally.	Apply external impact to compressor. Replace compressor.  • Replace terminal • Replace outdoor unit PWB • Replace outdoor unit PWB

### 9. Operation stops after a few minutes and restarts, and this process repeats

Main cause	Inspection method	Normal value/condition	Remedy
Dried-up electrolytic capacitor.	Measure 290-VDC line voltage.	300 V or higher.	Replace electrolytic capacitor.
Layer short-circuit in expansion valve coil.	Measure resistance.	46±3Ω in each phase (at 20°C )	Replace coil.

**CAUTION:** If fuse FU1/FU5 (outdoor unit control circuit board) is blown, be careful of charging voltage in inverter electrolytic capacitor C9, C10. To discharge stored electricity, unplug the power cord and connect the plug of a soldering iron (230VAC, 50W) between the positive and negative terminals of inverter electrolytic capacitor C9, C10.

## [6] MALFUNCTION (PARTS) CHECK METHOD

### 1. Procedure for determining defective outdoor unit IPM/compressor

The following flow chart shows a procedure for locating the cause of a malfunction when the compressor does not start up and a DC overcurrent indication error occurs.

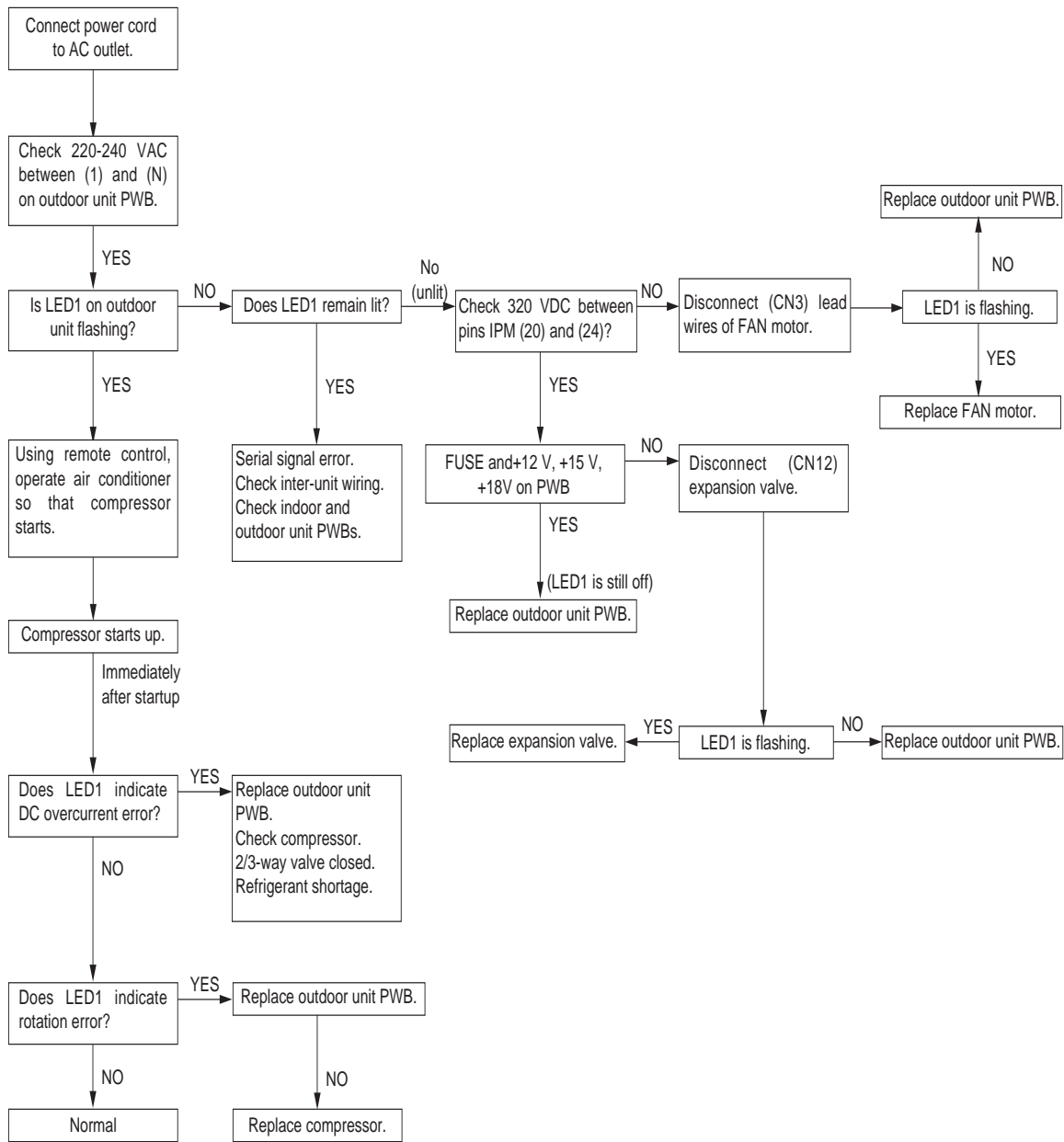

**CAUTION:** Please take care for electrical shock when you work to change defective parts or disconnect wires of defective application. The outdoor unit has energy changed for a while even after unplugging the power supply cord. After changing the part or unit, please retry check procedure from the beginning.



## 2. Procedure for determining defective expansion valve

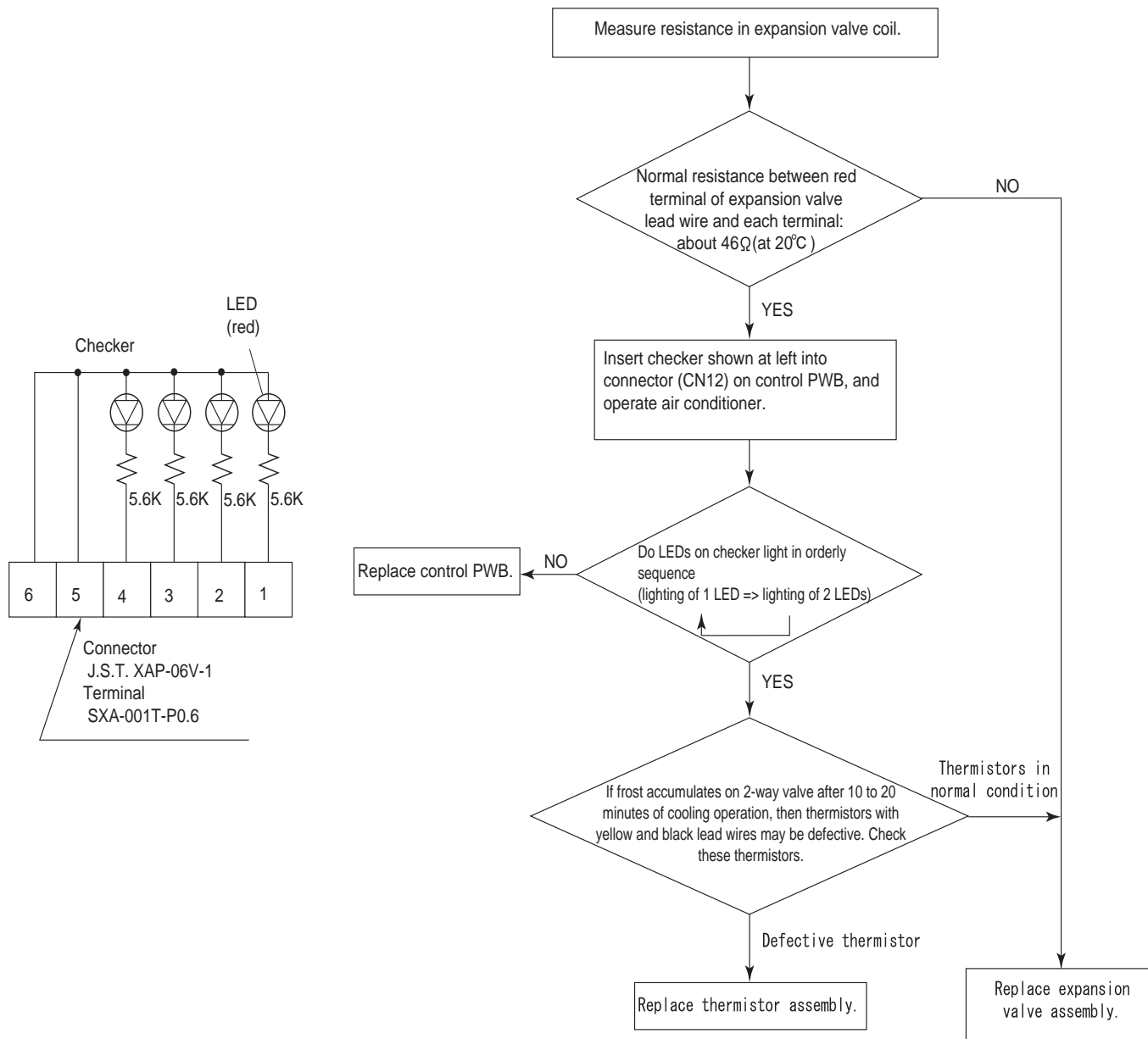

## 3. Diode bridge check method

Turn off the power and let the inverter electrolytic capacitor (C9, C10) discharge completely. Then use a tester and check continuity. When using a digital tester, the (+) and (-) tester lead wires in the table must be reversed.

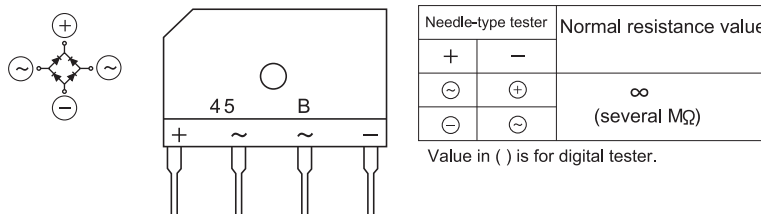

## 4. Inverter electrolytic capacitor (C9, C10) check method

Turn off the power, let the inverter electrolytic capacitor (C9, C10) discharge completely, and remove the capacitor from the control printed circuit board (PWB). First, check the case for cracks, deformation and other damages. Then, using a needle-type tester, check continuity.

### Determination of normal condition

The tester needle should move on the scale and slowly returns to the original position. The tester needle should move in the same way when polarities are reversed. (When measurement is taken with the polarities reversed, the tester needle exceeds the scale range. Therefore, let the capacitor discharge before measurement.)

**5. IPM check method**

Turn off the power, let the large capacity electrolytic capacitor (C10) discharge completely, and dismount the IPM. Then, using a tester, check leak current between C and E.

When using a digital tester, the (+) and (-) tester lead wires in the table must be reversed.

Needle-type tester		Normal resistance value
(-)	(+)	
P	N	∞ (several MΩ)
	U	
	V	
	W	

Needle-type tester		Normal resistance value
(-)	(+)	
U	N	∞ (several MΩ)
V		
W		

Values in ( ) are for digital tester.

**5.1. IPM internal circuit diagram**

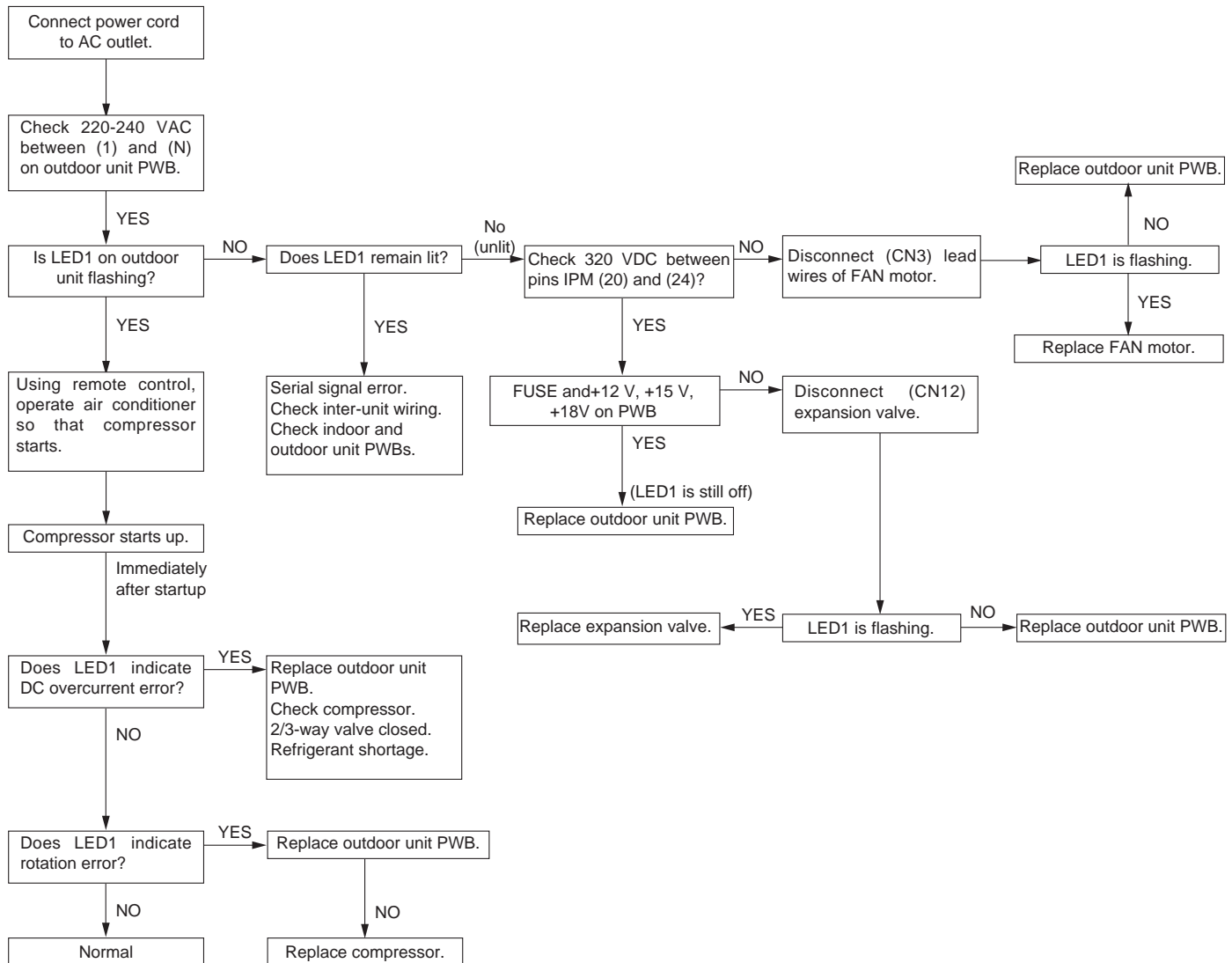

## [7] OUTDOOR UNIT CHECK METHOD

After repairing the outdoor unit, conduct the following inspection procedures to make sure that it has been repaired completely. Then, operate the compressor for a final operation check.

### 1. Checking procedures

No.	Item	Check method	Normal value/condition	Remedy
1	Preparation	Disconnect compressor cords (white, orange, red: 3 wires) from compressor terminals, and connect simulated load (lamp used as load). Operate air conditioner in cooling or heating test operation mode.		
2	Inverter DC power supply voltage check	Measure DC voltage between IPM pins (20) and (24).	320 VDC	Replace control PWB. Replace diode bridge. Correct soldered section of Fasten tabs (BT1,2,5,6,10,11, JPL1,2,5,6) on control PWB. (Repair solder cracks.)
3	IPM circuit check	Check that 3 lamps (load) light. Check position detection voltage (+15 V, 5 V) on control PWB.	Each voltage should be normal. All 3 lamps (load) should light with same intensity.	Replace control PWB.
4	Compressor check	Measure compressor coil resistance (for each phase of U, V and W). Use multi-meter or digital tester capable of displaying two digits right of the decimal point (0.01Ω).	Resistance value at 20 °C --- 0.65Ω	Correct connections at compressor terminals. Replace compressor.
5	Expansion valve check	Measure expansion valve coil resistance.	Each phase 46±3Ω (at 20 °C )	Replace expansion valve.
6	Final check	Turn off power, and connect compressor cords to compressor. Operate air conditioner. Measure DC voltage between IPM pins (20) and (24).	Compressor should operate normally. 320 VDC or higher.	Replace control PWB. Replace outdoor unit thermistor. Replace compressor (in case of compressor lock).

### 2. Troubleshooting of outdoor unit electric components

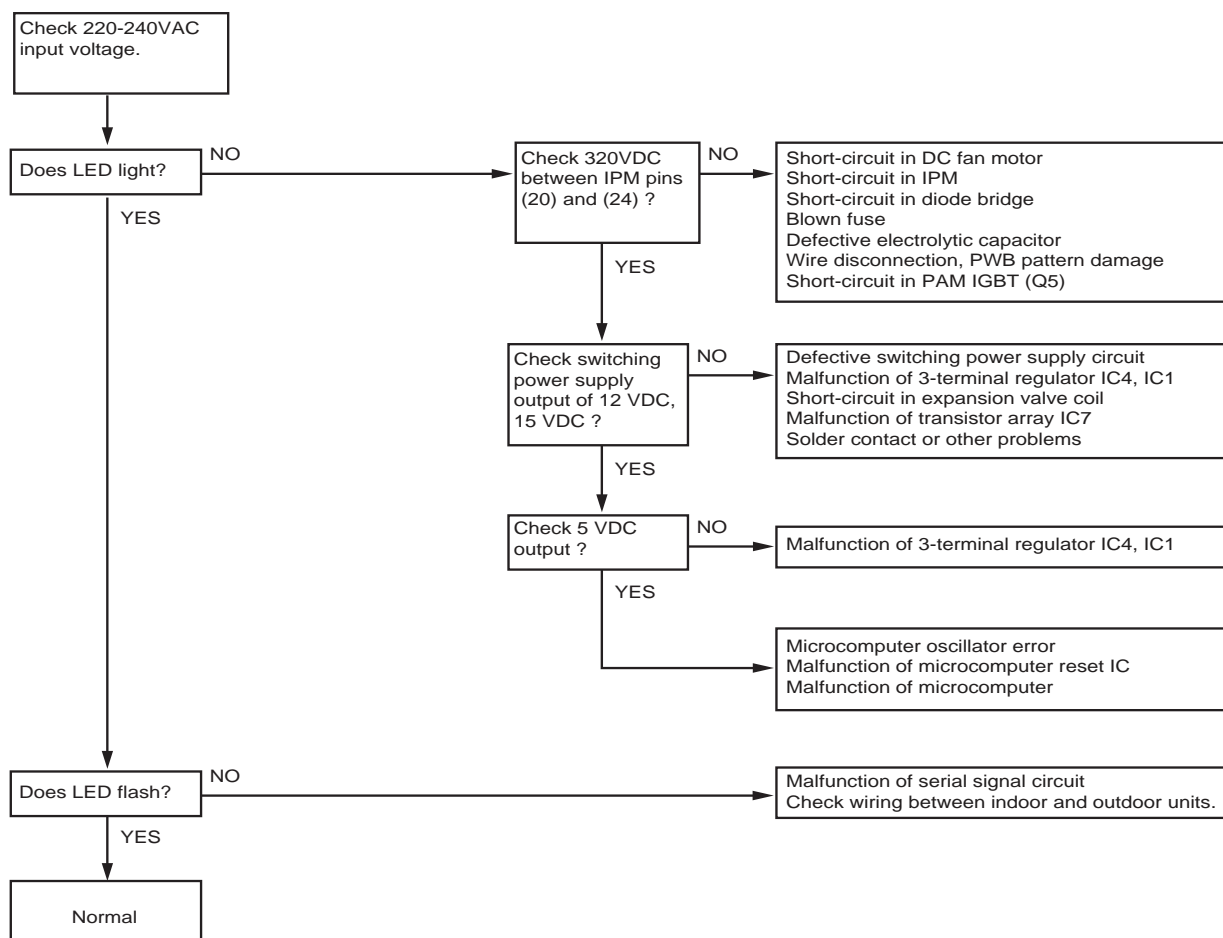

### 3. Caution in checking printed circuit boards (PWB)

#### 3.1. Non-insulated control circuit

The GND terminals of the low-voltage circuits (control circuits for microcomputer and thermistors and drive circuits for expansion valve and relays) on the control printed circuit board (PWB) are connected to the compressor drive power supply (320-VDC negative terminal). Therefore, exercise utmost caution to prevent electric shock.

If a measuring instrument used for the test is grounded, its chassis (ground) has the same electric potential as the 0-V probe. Since non-insulated circuits have the following voltage potential difference from the ground, connection of the grounding wire results in a short-circuit between the 0-V line and the ground, thus allowing an excessive current to flow to the tester to cause damage.

If the sheaths of the thermistor lead wires or expansion valve lead wires inside the outdoor unit become damaged due to pinching by the front panel or other metal parts or contacting a pipe, a high voltage can flow and destroy the circuits. To prevent these problems, carefully conduct assembly work.

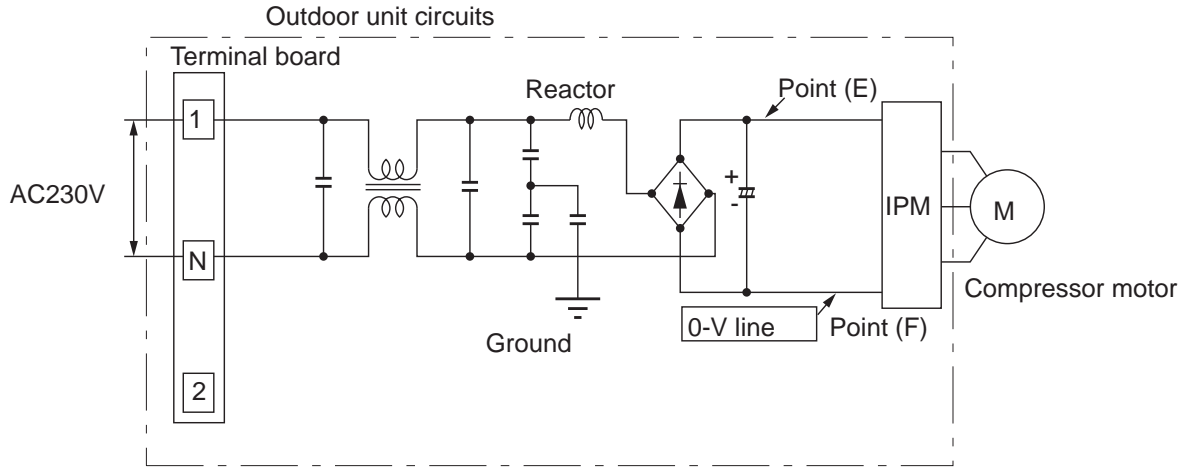

**Reason**

The oscilloscope (chassis ground) has the same electric potential as the 0-V probe. The entire electronic control section of the outdoor unit has a voltage potential difference from the ground as shown in the above diagram. When the oscilloscope is set up, the 0-V line and the ground voltage (ground) will be short-circuited, resulting in an excessive current flow to cause damage to the oscilloscope or indoor electric circuits.

## [8] TROUBLESHOOTING GUIDE

### 1. Self-Diagnosis Function and Display Mode

To display self-diagnosis result, hold down the AUX button for more than 5 seconds when the indoor unit is not operating.

- The number of indications displayed by the LEDs on the outdoor unit differs from that for the 2001 cooling unit models (for detailed display of malfunction information).

The display of malfunction No. differs from that of the 2001 cooling unit models. To show detailed malfunction information, two types of numbers flash alternately. (example: "21" ← → "-0")

- 1) The content of the self-diagnosis memory can be called out and displayed on the seven-segment display section on the indoor unit. (The error data cannot be called out for display by the LED on the outdoor unit.)
- 2) If the power cord is unplugged from the AC outlet or the circuit breaker is turned off, the self-diagnosis memory loses the stored data.

a) (\*1) The self-diagnosis display function of the indoor unit indicates the content of diagnosis by showing the error main category (number) and the error sub-category (-number) alternately in 1-second intervals on the seven segment display section of the indoor unit.

Example of self-diagnosis display on indoor unit: Compressor high-temperature error

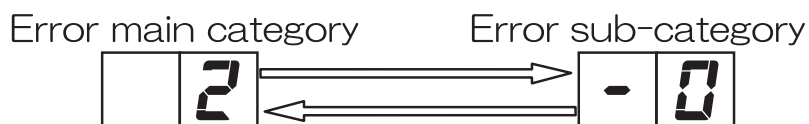

b) (\*2) The self-diagnosis display function of the outdoor unit indicates the error information by flashing LED1 on the outdoor unit according to the content of self-diagnosis.

The self-diagnosis display function of the outdoor unit is active only for about 3 to 10 minutes after self-diagnosis is performed during operation, and the display returns to normal condition after this display period.

The content of self-diagnosis cannot be called out by the self-diagnosis display function of the outdoor unit.

Example of self-diagnosis display on outdoor unit: Compressor high-temperature error

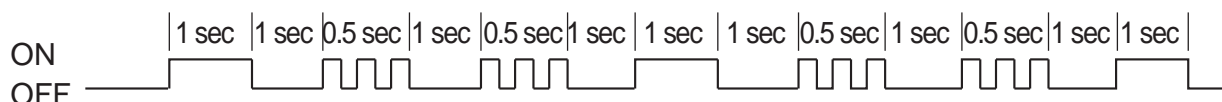

c) (\*3) The content of diagnosis is transferred to the indoor unit via serial communication, but it does not trigger a complete shutdown operation

● : Flashes in 2-sec. intervals (normal), ● : On, × : Off, ● : Flashes 3 times in 0.2-sec. intervals (When LED1 on the outdoor unit flashes in 2-sec. intervals, the outdoor unit is in normal condition.)

Status of indoor/outdoor units	Indication by LED1 on outdoor unit *2	Malfunction No. displayed on main unit display section		Content of diagnosis		Inspection location/method	Remedy		
		Main category	Sub-category	Main category	Sub-category				
Indoor/outdoor units in operation	● Normal flashing	0	0		Normal	-	-		
Indoor/outdoor units in complete shutdown	● 1 time	1	-0	Outdoor unit thermistor short-circuit	Heat exchanger thermistor short-circuit error	(1) Measure resistance of the outdoor unit thermistors. (TH2 to TH5: Approx. 4.4 kΩ at 25°C)	(1) Replace the outdoor unit thermistor assembly.		
			-1		Outside temperature thermistor short-circuit error			(2) Check the lead wire of the outdoor unit thermistor for torn sheath and short-circuit.	(2) Replace the outdoor unit thermistor assembly.
			-2		Suction thermistor short-circuit error			(3) No abnormality found in above inspections (1) and (2).	(3) Replace the outdoor unit control PWB -3 2-way valve ther- assembly.
			-3		2-way valve thermistor short circuit error				

Status of indoor / outdoor units	Indication by LED1 on outdoor unit*2	Malfunction No. displayed on main unit display section *1		Content of diagnosis		Inspection location/method	Remedy		
		Main category	Sub-category	Main category	Sub-category				
Indoor/ outdoor units in complete shutdown	● 2 times	2	-0	Cycle temperature	Compressor hightemperature error	(1) Check the outdoor unit air outlet for blockage.  (2) Check if the power supply voltage is 200 V or higher at full power.  (3) Check the pipe connections for refrigerant leaks.  (4) Measure resistance of the outdoor unit compressor thermistor. (TH1: Approx. 53 kΩ at 25°C)  (5) Check the expansion valve for proper operation.	(1) Ensure unobstructed air flow from the outdoor unit air outlet.  (2) Connect power supply of proper voltage.  (3) Charge the specified amount of refrigerant.  (4) Replace the outdoor unit compressor thermistor assembly.  (5) Replace the expansion valve coil, expansion valve or outdoor unit control PWB assembly.		
					Indoor unit in operation Outdoor unit in temporary stop	-1	Temporary stop due to compressor discharge overheat *3	(Temporary stop for cycle protection)	–
					-2	Temporary stop due to outdoor unit heat exchanger overheat *3	(Temporary stop for cycle protection)	–	
					-3	Temporary stop due to outdoor unit heat exchanger overheat *3	(Temporary stop for cycle protection)	–	
					-4	Temporary stop due to 2-way valve freeze *3	(Temporary stop for cycle protection)	–	
Indoor unit in operation Outdoor unit in temporary stop	● 3 times	3	-0	Dry operation	Temporary stop due to dehumidifying operation *3	(Temporary stop for cycle protection)	–		
Indoor/ outdoor units in complete shutdown	● 5 times	5	-0	Outdoor unit thermistor open-circuit	Heat exchanger thermistor open circuit error	1) Check connector CN8 of the outdoor unit thermistor for secure installation.	1) Correct the installation.		
					-1	Outside temperature thermistor open-circuit error	(2) Measure resistance of outdoor thermistors TH1 to TH5.	(2) Replace the outdoor unit thermistor assembly.	
					-2	Suction thermistor open-circuit error	(3) Check the lead wires of thermistors TH1 to TH5 on the outdoor unit control PWB for open-circuit	(3) Replace the outdoor unit thermistor assembly.	
					-3	2-way valve thermistor open-circuit error	(4) No abnormality found in above inspections (1) through (3).	(4) Replace the outdoor unit control PWB assembly.	
					-4	Discharge thermistor open-circuit error			

Status of indoor/ outdoor units	Indication by LED1 on outdoor unit*2	Malfunction No. displayed on main unit display section *1		Content of diagnosis		Inspection location/method	Remedy
		Main category	Sub-category	Main category	Sub-category		
Indoor/ outdoor units in complete shutdown	● 6 times	6	-0	Outdoor unit DC	DC over current error	(1) IPM continuity check  (2) Check the IPM and heat sink for secure installation.  (3) Check the outdoor unit fan motor for proper rotation.  (4) No abnormality found in above inspections (1) through (3).  (5) No abnormality found in above inspections (1) through (4).	(1) Replace the outdoor unit control PWB assembly.  (2) Correct the installation (tighten the screws).  (3) Replace the outdoor unit fan motor.  (4) Replace the outdoor unit control PWB assembly.  (5) Replace the compressor.
			-1		IPM pin level error	Check the IPM is attached correctly to the outdoor unit control PWB.	Replace the outdoor unit control PWB assembly.
Indoor/ outdoor units in complete shutdown	● 7 times	7	-0	Outdoor unit AC	AC over current error	(1) Check the outdoor unit air outlet for blockage  (2) Check the outdoor unit fan for proper rotation.	(1) Ensure unobstructed air flow from the outdoor unit air outlet.  (2) Check the outdoor unit fan motor.
			-1		AC over current error in OFF status	(1) IPM continuity check	(1) Replace the outdoor unit control PWB assembly.
			-2		AC maximum current error	(1) Check the outdoor unit air outlet for blockage.  (2) Check the outdoor unit fan for proper rotation.	(1) Ensure unobstructed air flow from the outdoor unit air outlet.  (1) Check the outdoor unit fan motor.
			-3		AC current deficiency error	(1) Check if there is an opencircuit in the secondary winding of the current transformer of the outdoor unit control PWB.  (2) Check if the refrigerant volume is abnormally low.  (3) Check if the refrigerant flows properly.	(1) Replace the outdoor unit control PWB assembly.  (2) Charge the specified amount of refrigerant.  (3) Correct refrigerant clogs. (2-way valve, 3-way valve, pipe, expansion valve)

Status of indoor/ outdoor units	Indication by LED1 on outdoor unit*2	Malfunction No. displayed on main unit display section *1		Content of diagnosis		Inspection location/method	Remedy		
		Main category	Sub-category	Main category	Sub-category				
Indoor/ outdoor units in complete shutdown	● 9 times	9	-0	Outdoor unit cooling/heating switch over	Thermistor installation error or 4-way valve error	(1) Check to make sure outdoor unit thermistor TH2 (heat exchanger) and TH5 (2-way valve) are installed in correct positions. (2) Measure resistance of thermistors TH1 and TH5. (3) Check the 4-way valve for proper operation. (4) No abnormality found in above inspections (1) through (3).	(1) Correct the installation. (2) Replace the thermistor assembly. (3) Replace the 4-way valve. (4) Replace the outdoor unit control PWB assembly.		
			-3		Torque control error			(1) Check if the refrigerant volume is abnormally low. (2) Check the 4-way valve for proper operation. (3) check to see compressor type is correct.	(1) Change the specified amount of refrigerant. (2) Replace the 4-way valve. (3) Replace the compressor with the correct part.
			-4		Gas leak error				
Indoor/ outdoor units in complete shutdown	● 10 times	10	-0	EEPROM error	EEPROM (outdoor) error		(1) Replace the outdoor unit control PWB -1 EEPROM (outdoor) assembly.		
			-1		EEPROM (outdoor) assembly. data error				
Indoor/ outdoor units in complete shutdown	● 11 times	11	-0	Outdoor unit DC fan	Outdoor unit DC fan rotation error	(1) Check connector CN3 of the outdoor unit DC fan motor for secure installation.	(1) Correct the installation.		
						(2) Check the outdoor unit fan motor for proper rotation.	(2) Replace the outdoor unit fan motor.		
						(3) Check fuse FU3.	(3) Replace the outdoor unit control PWB assembly.		
						(4) Outdoor unit control PWB	(4) Replace the outdoor unit control PWB assembly.		
Indoor/ outdoor units in complete shutdown	● 12 times	12	-0	outdoor terminal board fus	outdoor terminal board fuse open error	(1) Check connector CN10 for secure installation. (2) Check the fuse open of outdoor terminal board.	(1) Correct the installation. (2) Replace the outdoor terminal board.		



Status of indoor/ outdoor units	Indication by LED1 on outdoor unit*2	Malfunction No. displayed on main unit display section *1		Content of diagnosis		Inspection location/method	Remedy
		Main category	Sub- category	Main category	Sub-category		
Indoor/ outdoor units in complete shutdown	● 13 times	13	-0	DC compressor	Compressor startup error	(1) Check the colors (red, white, orange) of the compressor cords for proper connection. (PWB side, compressor side)	(1) Correct the installation. (U: Red, V: White, W: Orange)
			-1		Compressor rotation error (120° energizing error)	(2) Check if the IPM terminal resistance values are uniform.  (3) No abnormality found in above inspections (1) and (2).	(2) Replace the outdoor unit control PWB assembly.  (3) Replace the outdoor unit control PWB assembly.
			-2		Compressor rotation error (180° energizing error)	(4) No abnormality found in above inspections (1) through (3).	(4) Replace the compressor.
			-3		Inverter current detection circuit error	Check inverter current detection circuit.	Replace the outdoor unit control PWB assembly.
Indoor/ outdoor units in complete shutdown	● 14 times	14	-0	Outdoor unit PAM	PAM over voltage error Compressor rotation error	(1) Check the AC power supply voltage for fluctuation.  (2) No abnormality found in above inspection (1).	(1) Connect stable power supply.  (2) Replace the outdoor unit control PWB assembly.
Indoor/ outdoor units in operation			-1		PAM clock error	(1) Check the PAM clock for proper input.	(1) Replace the outdoor unit control PWB assembly.
Indoor unit in operation Outdoor unit in complete shutdown	●	17	-0	Wires between units	Serial open-circuit	(1) Check the wires between units.  (2) Check voltage between Nos. 1 and 2 on the indoor/outdoor unit terminal boards.	(1) Connect stable power supply.  (2) Replace the outdoor unit control PCB assembly.
			×		-0	Outdoor unit does not turn on due to erroneous wiring	(1) Check the wires between units.
	(2) Check the outdoor unit fuse.	(2) Replace the fuse/ outdoor unit control PCB assembly.					
	(3) Check 15-V, 13-V and 5-V voltages on the PWB. Check resistance between IPM terminals.	(3) Replace the outdoor unit control PCB assembly.					
	(4) Check pins No. 5 and 7 of connector CN3 of the outdoor unit fan motor for short-circuit.	(4) Replace the outdoor unit fan motor.					
	(5) Outdoor unit control PCB	(5) Replace the outdoor unit control PCB board.					
●	18	-0	Serial short-circuit	(1) Check the wires between units.	(1) Correct the wiring.		
		-1		Serial erroneous wiring	(1) Check the wires between units.	(1) Correct the wiring.	

Status of indoor/outdoor units	Indication by LED1 on outdoor unit*2	Malfunction No. displayed on main unit display section *1		Content of diagnosis		Inspection location/method	Remedy
		Main category	Sub-category	Main category	Sub-category		
Indoor/outdoor units in complete shutdown	×	19	-0	Indoor unit fan	Indoor unit fan error	(1) Check the indoor fan motor for proper rotating operation. (Check fan lock.) (2) Check the lead wire of the indoor fan motor for opencircuit. (3) Check CN3 of the indoor unit fan motor for secure installation. (4) No abnormality found in above inspections (1) through (3).	(1) Replace the indoor fan motor.  (2) Replace the indoor fan motor.  (3) Correct the installation of CN3 of the indoor fan motor.  (4) Replace the indoor unit control PWB.
Indoor/outdoor units in operation	×	20	-0	Indoor unit control PCB	EEPROM data error	(EEPROM read data error)	Replace the indoor unit control PWB.
Indoor/outdoor units in operation	×	29	-0	Panel	Panel open error	(1) Caught of panel hook	(1) Replace or adjustment of the panel.  (2) Replace the limit switch.
			-1		Panel close error	(2) Limit switch breakdown	
Indoor/outdoor units in operation	×	88		Control and display PCB	Communication error	(1) Check for disconnected connector between control PCB and display PCB, and open-circuit in lead wires.  (2) Check that control PCB outputs signals correctly.	(1) Insert connectors correctly, or replace control PWB.  (2) Replace control PWB.

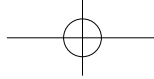

Malfunction indications due to erroneous wiring during air conditioner installation

Inter-unit wiring error mode		Symptom	
1	<p>Indoor unit</p> <p>Outdoor unit</p>	Malfunction diagnosis display	"18-1"
2	<p>Indoor unit</p> <p>Outdoor unit</p>	Malfunction diagnosis display	None (Displays "18-0" when malfunction code is called out.)
3	<p>Indoor unit</p> <p>Outdoor unit</p>	Malfunction diagnosis display	None (Displays "18-0" when malfunction code is called out.)
4	<p>Indoor unit</p> <p>Outdoor unit</p>	Malfunction diagnosis display	"18-1"
5	<p>Indoor unit</p> <p>Outdoor unit</p>	Malfunction diagnosis display	"18-1"

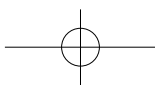
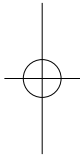
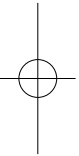
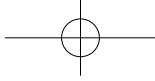



## [2] PERFORMANCE CURVES

### NOTE

- 1) Indoor fan speed: Hi
- 2) Open Panel/Vertical Louvre: Auto; Horizontal Louvre: Center
- 3) Indoor air temp. : Cooling 27°C, Heating 20°C
- 4) Power source : 230V, 50Hz

### 1.1. At Cooling

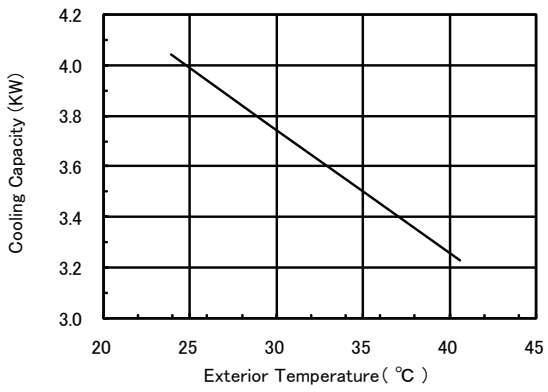
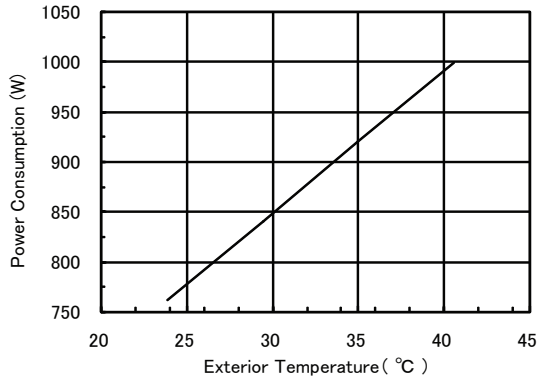

### 1.2. At Heating

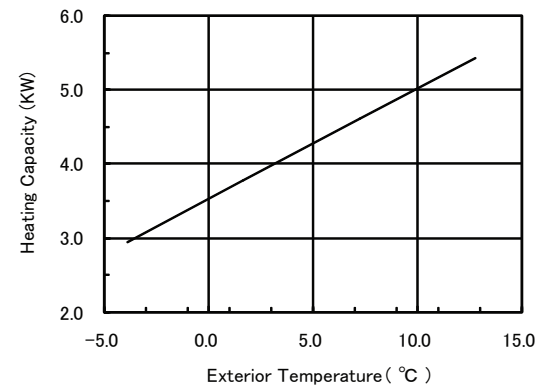
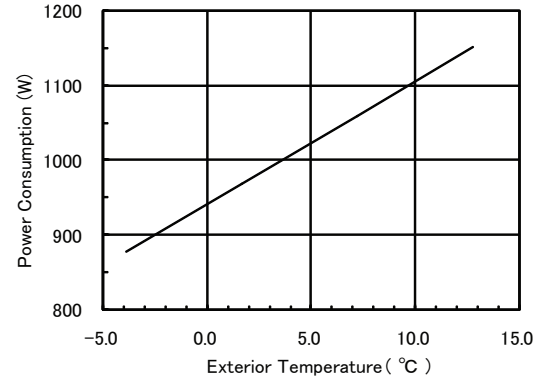

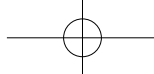

## CHAPTER 5. DISASSEMBLY PROCEDURE

If, in carrying out repairs and modifications, the work requires the use of arc- and flame-producing apparatus, such as welding, brazing and soldering equipment, this work shall only be started after the rooms have been thoroughly ventilated. While the work is being carried out, the mechanical ventilation, if any, shall be kept in constant operation and all windows and doors kept open. In the case of repairs to parts of the refrigerant circuit, it may be necessary that not only the workman but also a second person shall be present for observation and assistance.

Necessary protective equipment shall be available and, in the case of open flames or arcs, fire extinguishing apparatus shall be ready to hand.

Welding and brazing shall be carried out by qualified workmen.

### [1] DISASSEMBLY OF INDOOR UNIT

Be sure to disconnect the power cord from the AC power outlet before starting the disassembly procedure. When reassembling the unit after repairing, be sure to install screws to their original positions.

The screws used are not the same in specifications such as corrosion-resistant treatment, tip shape and length.

After the air conditioner is repaired or parts are replaced, measure insulation resistance of the equipment using an insulation resistance meter. If the measured resistance is lower than 1 MΩ, inspect parts and repair or replace defective parts.

1) The lock button on a lower both sides of the panel is pushed.

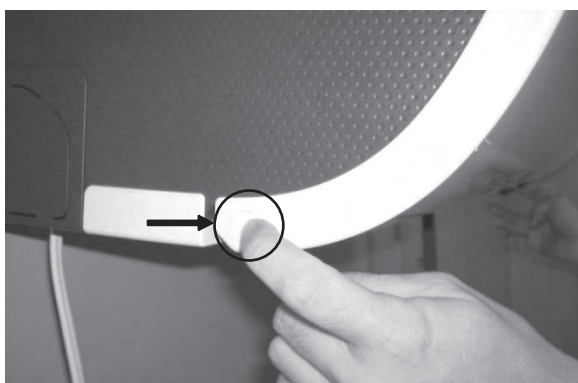

4) The filter cover is opened, and one screw at the center is removed.



2) The lower side of the panel is pulled forward.



5) The 2 screw covers are removed. (plunder the balloon entrance)

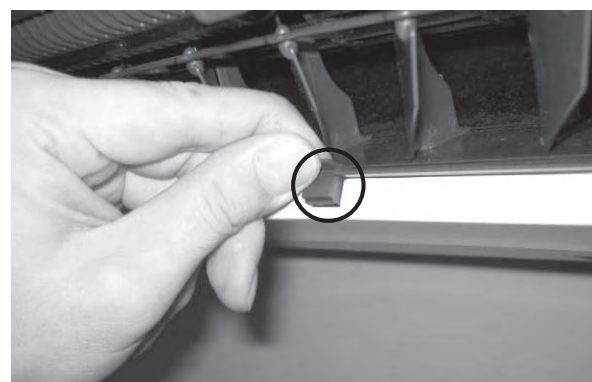

3) The panel is raised up and removed.

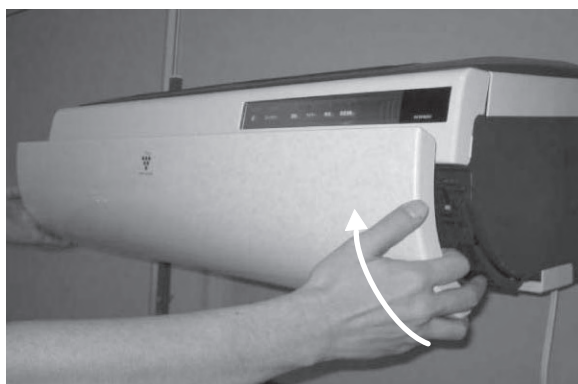

6) The 2 screws are removed.

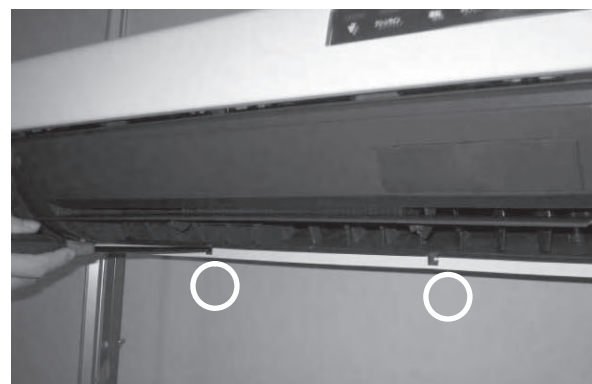

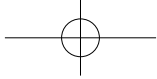

12PHR-N

### 1. MAIN UNIT

7) Remove the connector cover. (use the (-) screwdriver).



11) The tapes that are the fixation of the lead wire are peeled off.

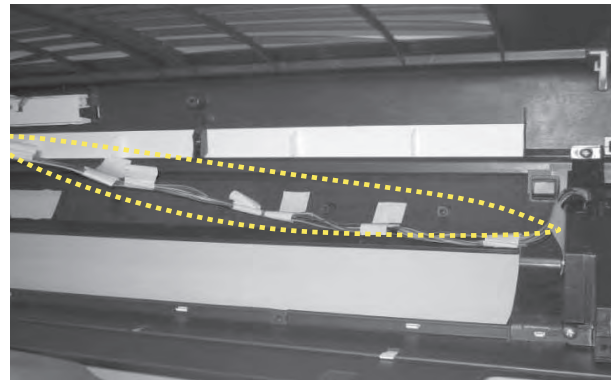

8) All of the nine connectors are removed.

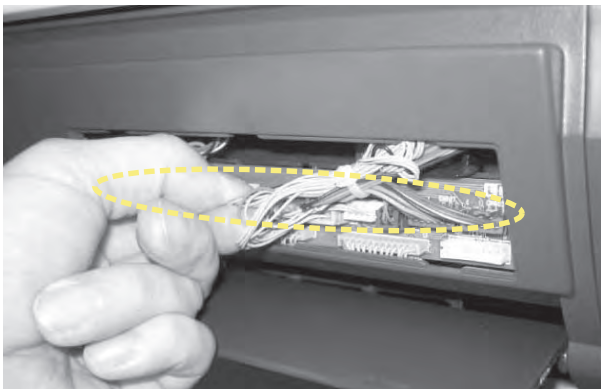

12) The panel base is drawn out forward. (both sides)



9) The hook three places of the part interior of front panel are removed.

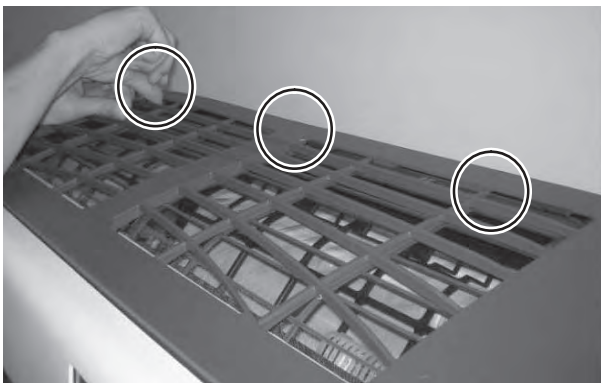

13) The gear is turned, and the panel base is removed. For a minus screw driver etc.

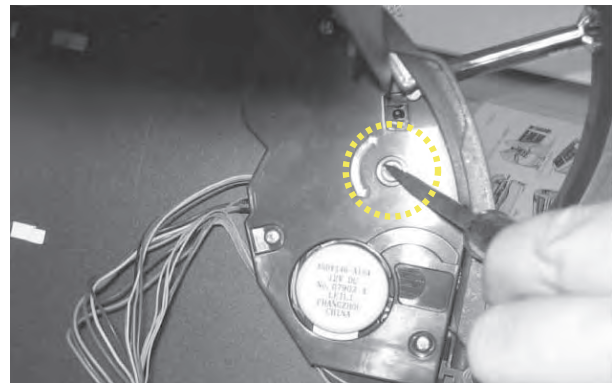

10) Front panel is pulled to front this side and removed.



14) The pin that is the fixation of the panel base and the link is removed.

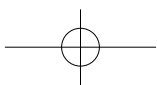
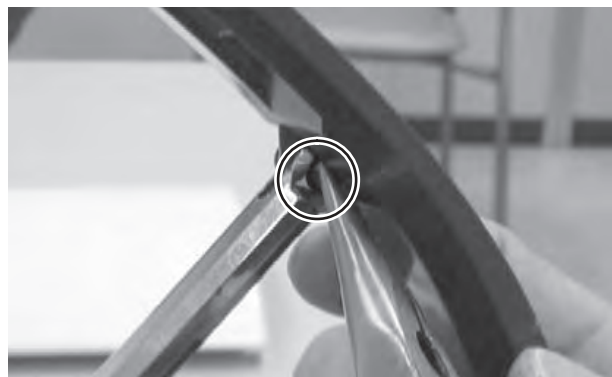



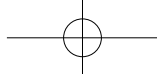

15)The panel mechanism assembly is removed. (2 screws)

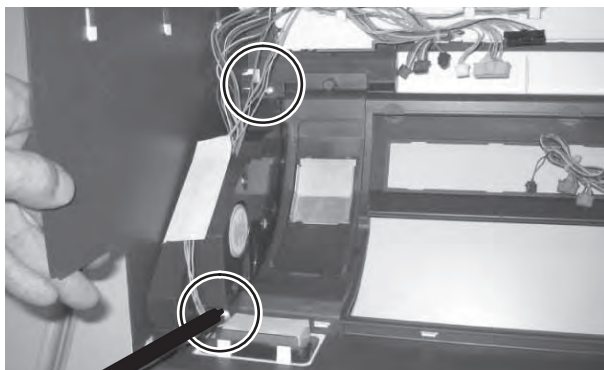

19)The display printed board is removed. (Hook three places)

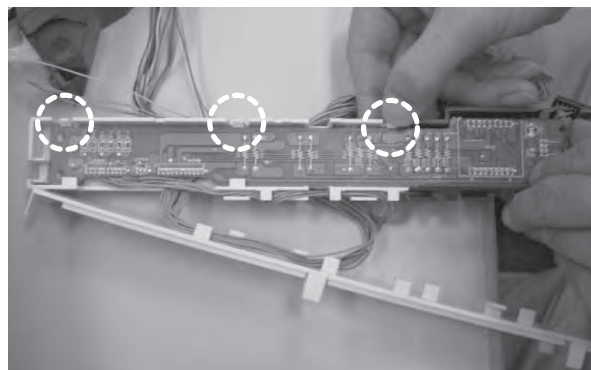

16)The display assembly is removed. (right and left two hooks place)

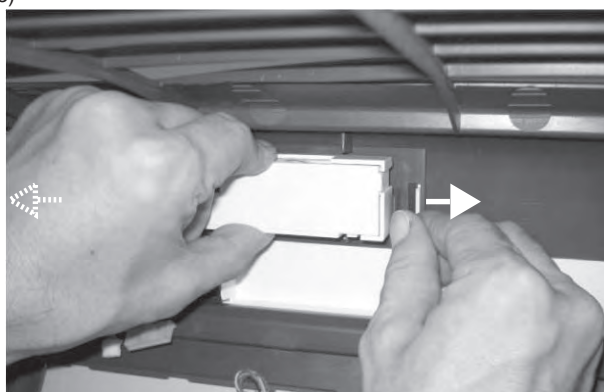

20)The panel mechanism cover is removed. (3 screws)

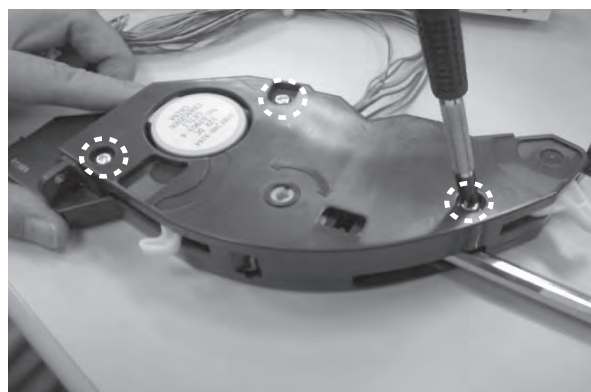

17)The cover of the display printed board is removed.



21)The screw that is the fixation of the panel motor is removed, and is turned to the left and it is removed.

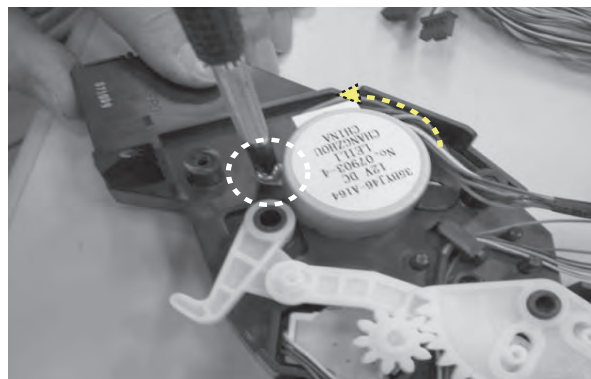

18)The display panel is removed.

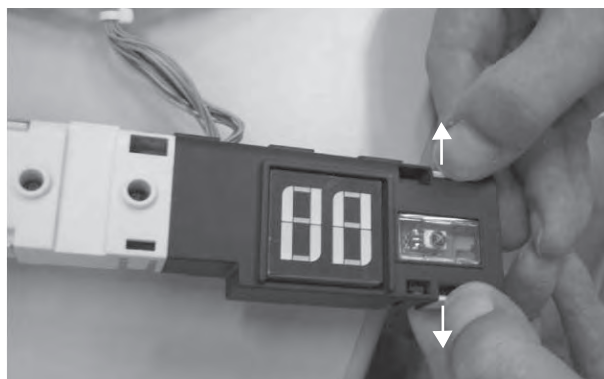

22)The gear, the crank, and the arm are removed.

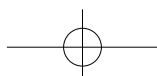
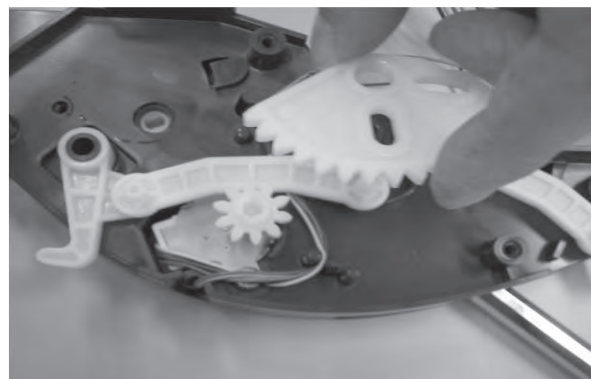

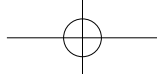

12PHR-N

23)The panel motor is removed. (2 screws)

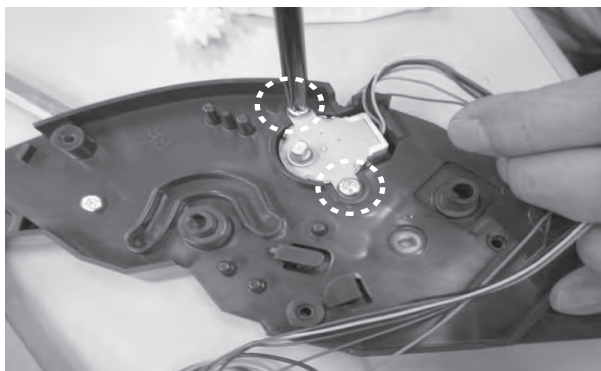

27)The reception cover is removed.

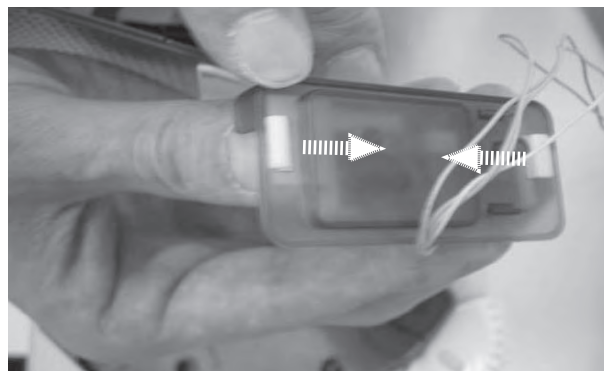

24)The mechanism case is removed. (Hook one place)

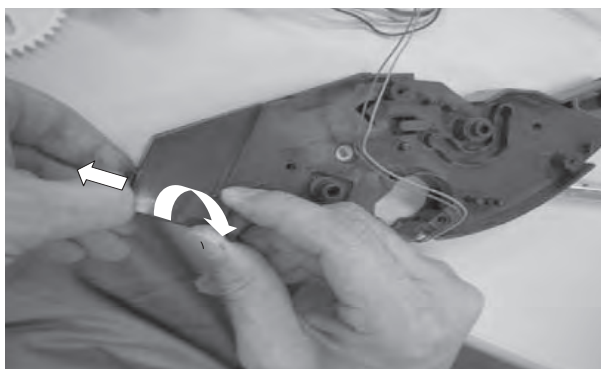

28)A fixed screw for P.W.B. box cover is removed.

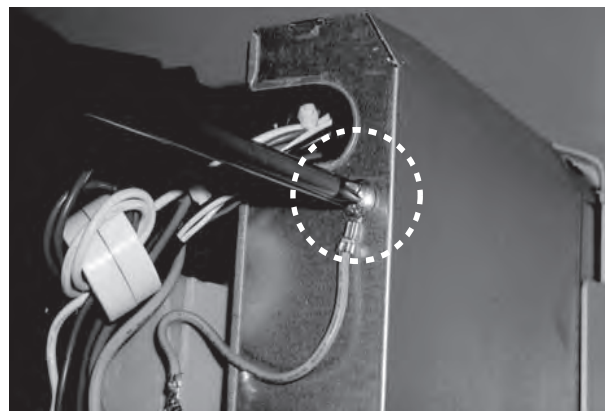

25)The limit switch is removed.

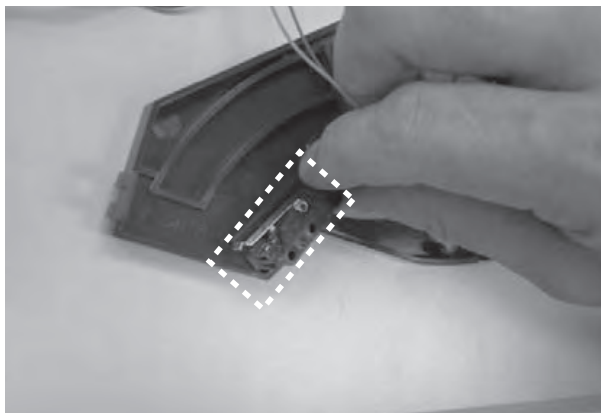

29)Hook is removed by handling a minus driver.

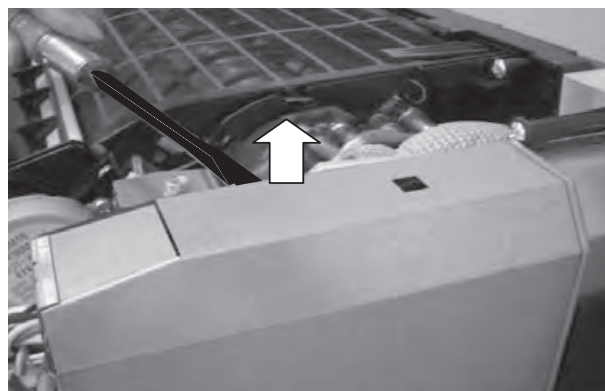

26)The reception part is removed. (Hook two places)

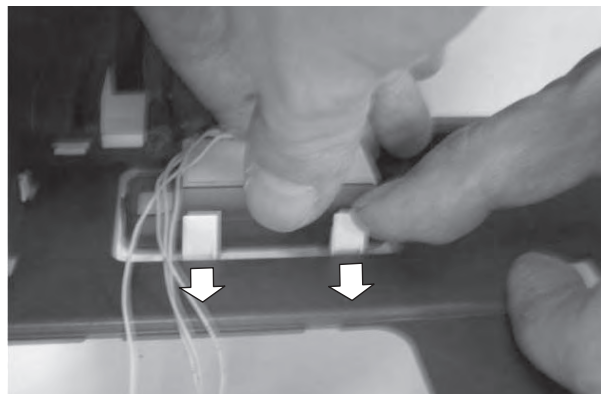

30)The P.W.B. box cover is removed.

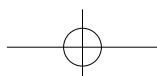

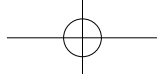

31)The fixing band in the P.W.B.assembly is cut. (4 parts)

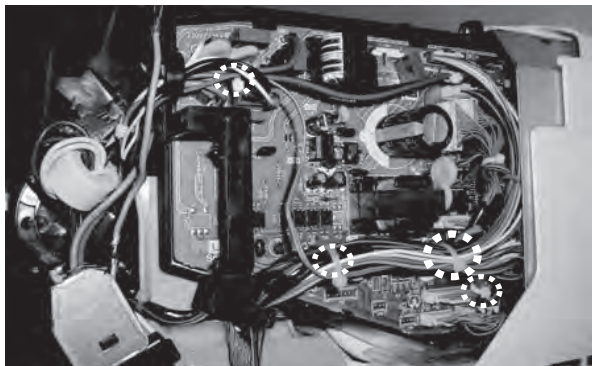

35)The plasmacluster assembly is pulled forward, and detached.

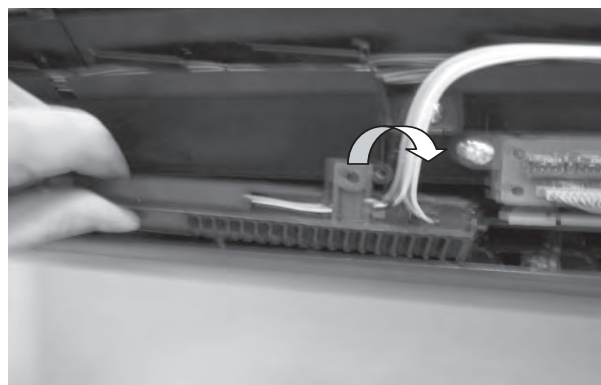

32)The connectors in nine places are removed.

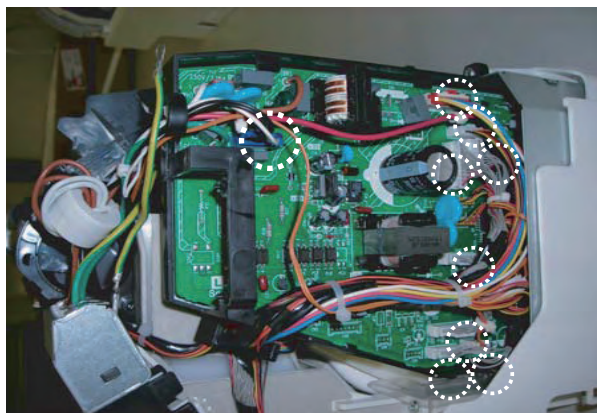

36)Two hooks of the plasmacluster cover are removed by using (-) screwdriver.



33)The Terminal board removed. (1 screw )

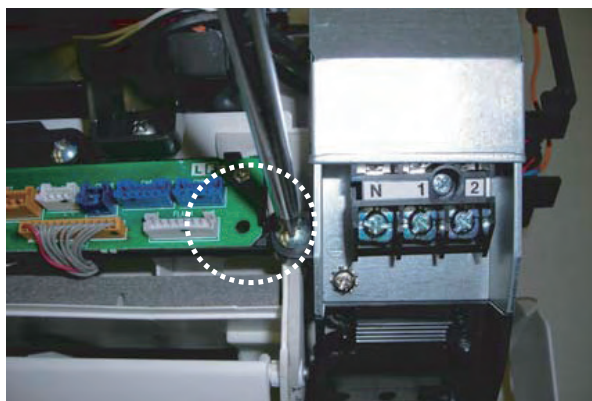

37)After the plasmacluster that removes the PC cover is taken out, the wire connector is removed.

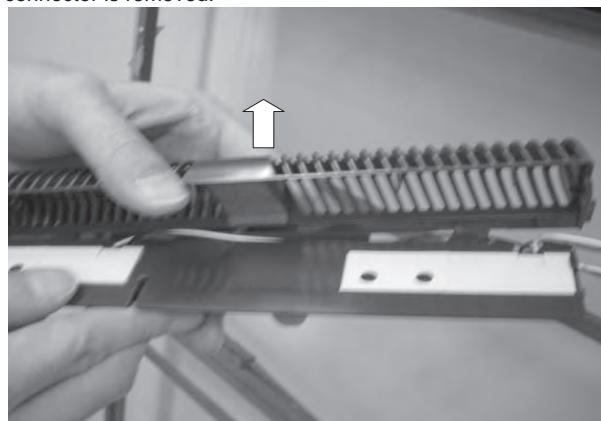

34)The plasmacluster assembly is removed. (2 screws)

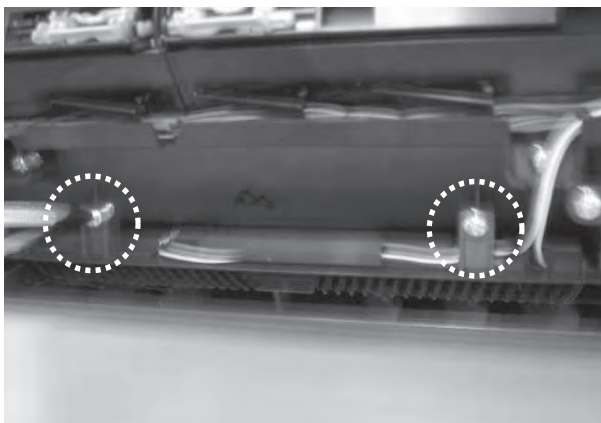

38)Six screws for the fixation of the air filter cleaning mechanism assembly is removed.

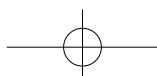
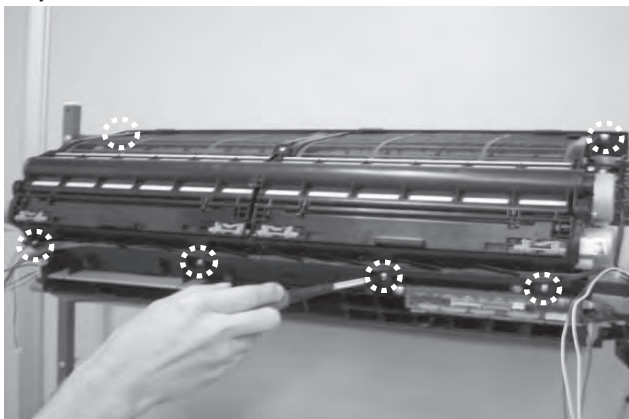

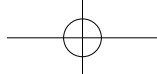

# 12PHR-N

39) Air filter cleaning mechanism assembly is pulled forward and removed.

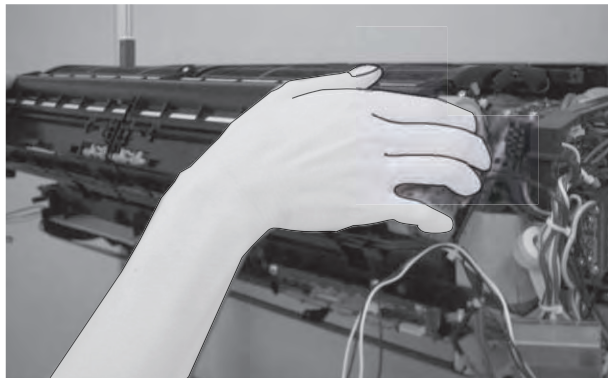

43) The thermally sensitive resistor holder is removed. (Hook two places)

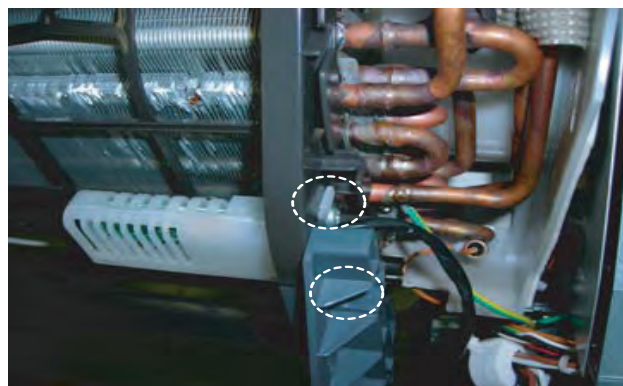

40) The limit switch cover is removed.

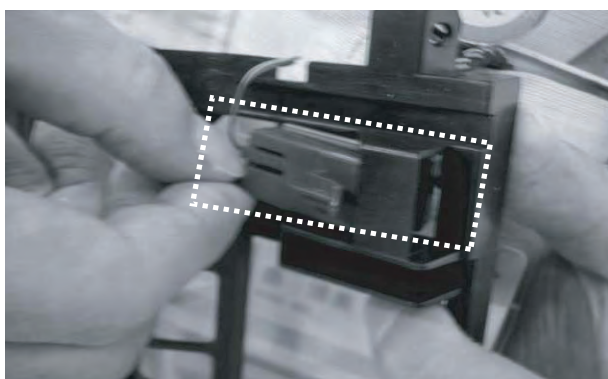

44) The relay printed board holder removed. (2 screws)



41) The limit switch is removed. (Hook one place)

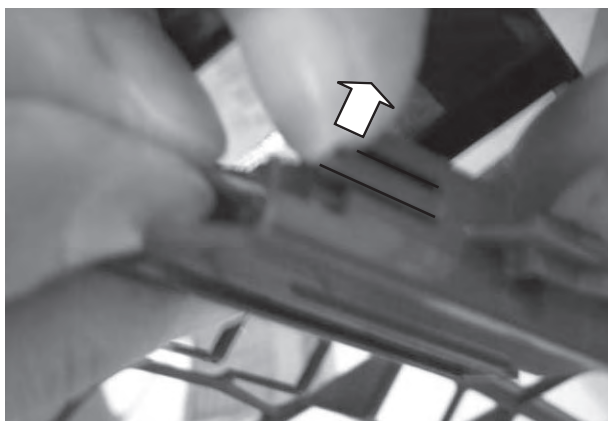

45) P.W.B. assembly is removed. (2 screws)

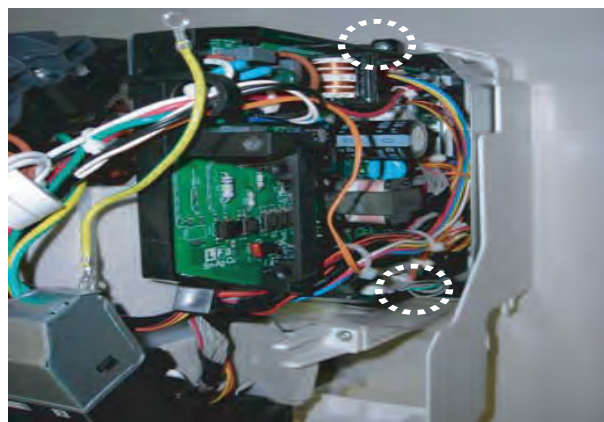

42) The wire connector of the limit switch is removed.



46) The earth cable is removed. (1 earth screw)

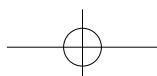

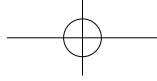

47)The P.W.B.assembly is drawn out forward.

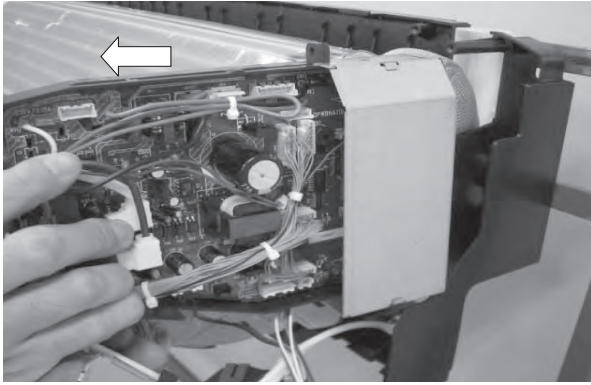

51)Two screws of cover L are removed.

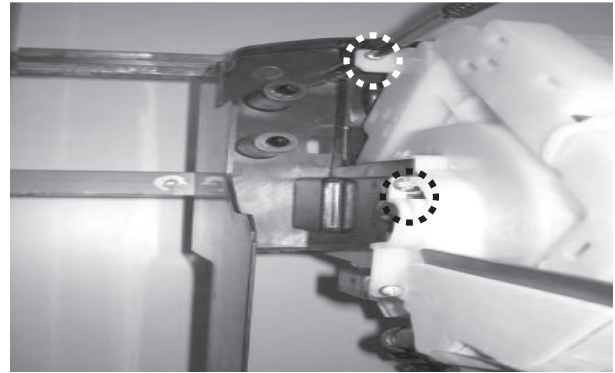

48)The Terminal cover of the Terminal stand assembly is removed. (Hook two places)

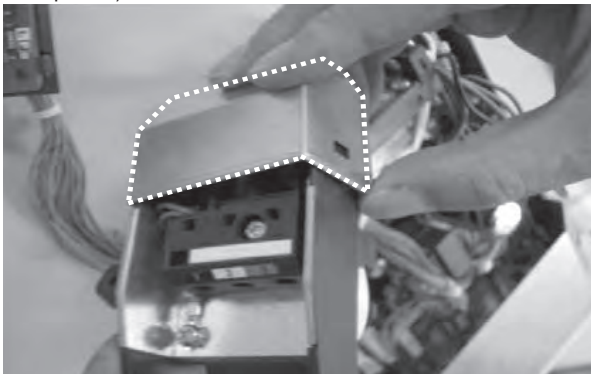

52)Two screws for the evaporator fixation (right side) are removed.

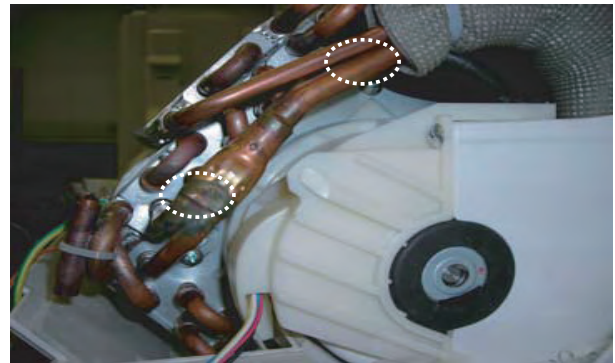

49)The P.W.B. box cover is removed. (Hook one place) And the control board unit is removed.

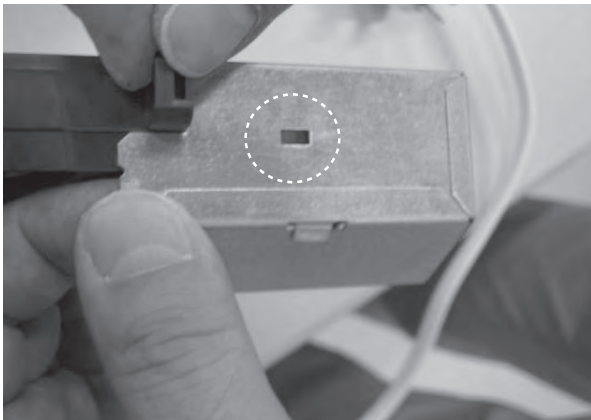

53)One screw for the drain pan fixation (right side) is removed.



50)The dew cover is removed. (The slide is done right and remove. )

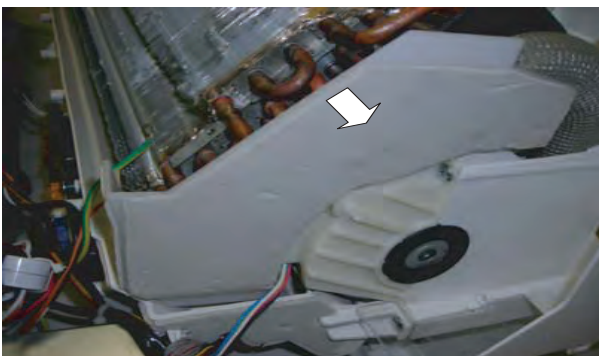

54)The drain pan is detached.

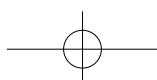

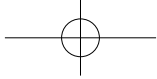

# 12PHR-N

55) Four fixed screws of the vertical direction louver stand assembly removed.

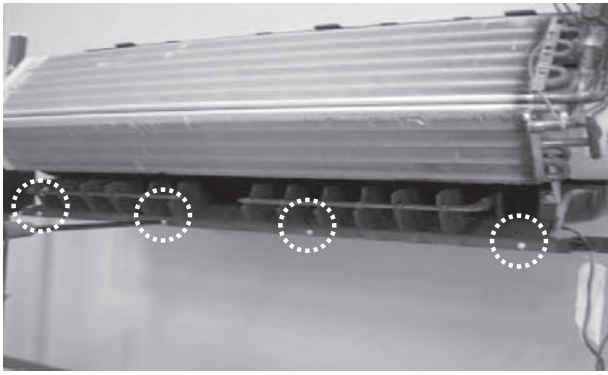

56) Driving motor of the vertical direction louver stand assembly is removed. (2 screws)

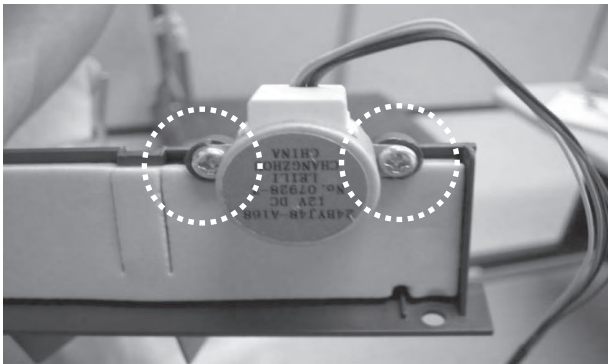

57) The bearing holder is removed. (1 screw)

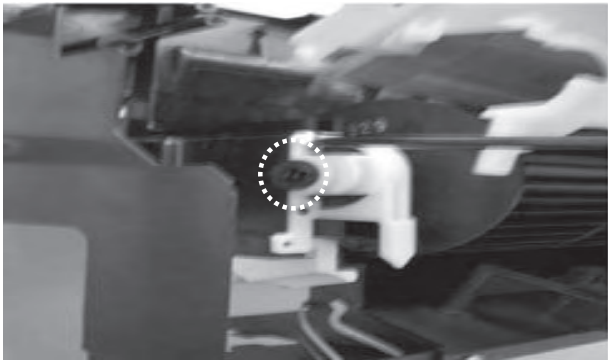

58) The cross flow fan fixation screw is loosened.

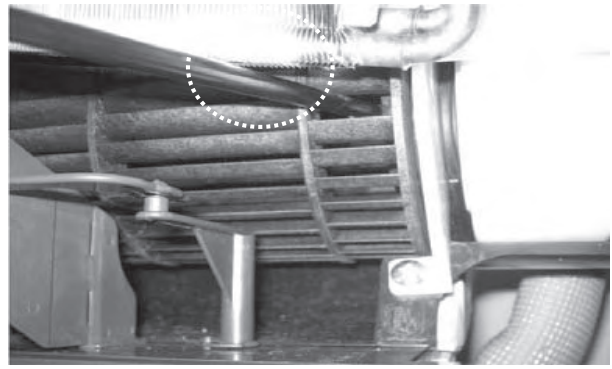

59) The two screws for the fan motor cover fixation are removed.

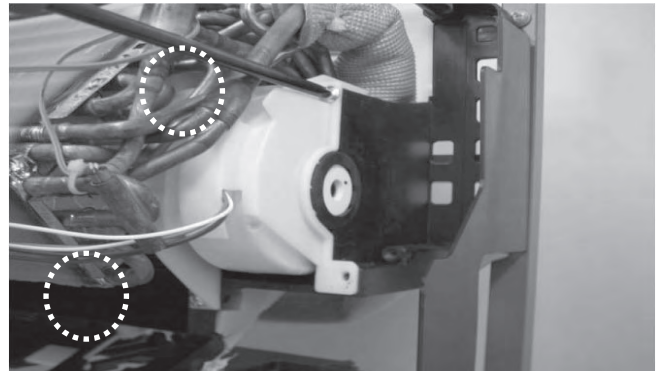

60) The cross flow fan is pulled out at the left of the unit and it removes.

61) Fan motor is removed.

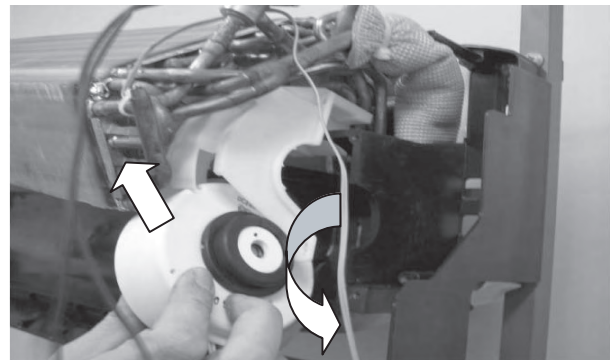

## [2] DISASSEMBLY OF OUTDOOR UNIT

1) The fixed screw of control box cover is removed and control box cover is removed.

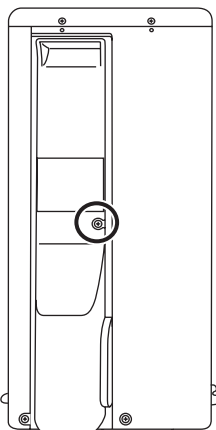

2) The 2 screws on the right-hand side of top plate ass'y is removed.

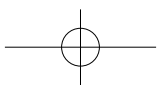
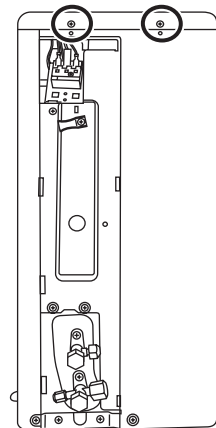

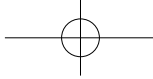

3) The 2 screws on the left-hand side of top plate ass'y is removed.

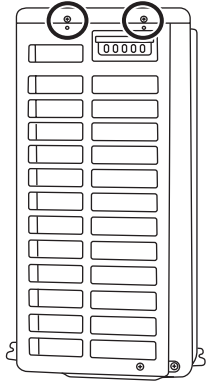

7) The 5 screws on the right-hand side of side cover R is removed.

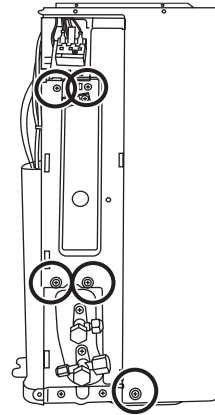

4) The screw on the right-hand side of front panel is removed

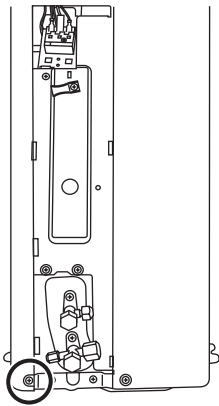

8) The 2 screws on the right-hand side of side cover L is removed.

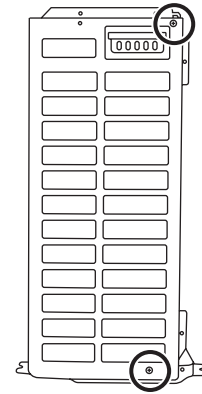

5) The screw on the right-hand side of front panel is removed

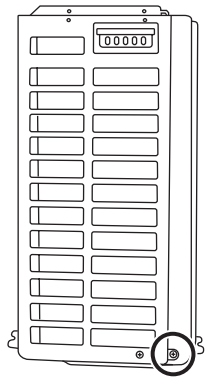

9) The 7 screws of the side cover L and side cover R back is removed.

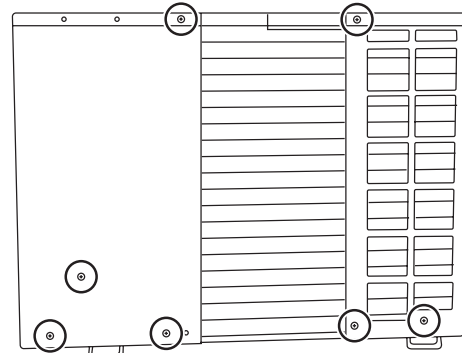

6) The 4 screws of the front of a front panel is removed.

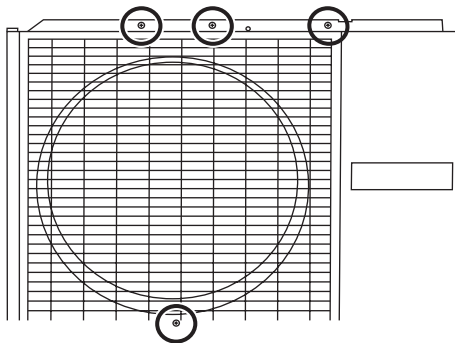

10) Remove the connectors of the control box and reactor, then unscrew 2 screws fixing control box

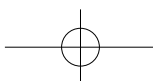
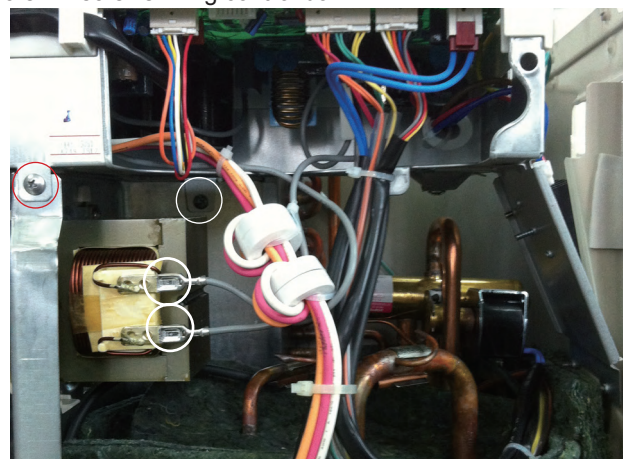

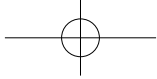

12PHR-N

11) A bulkhead plate fixed 2 screws is removed.

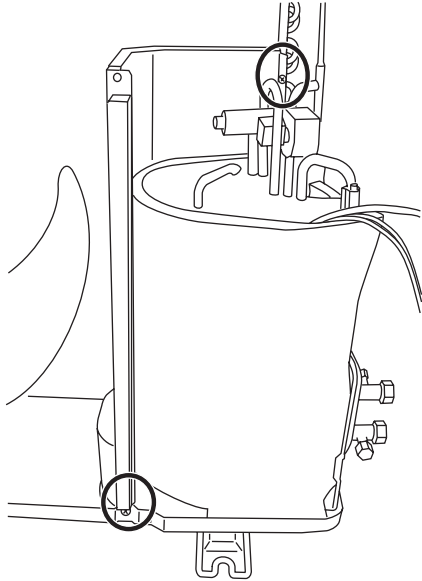

15) The compressor cover is removed.



12) The compressor covers 1, 2 removed.



16) A thermistor is removed. (1 place)

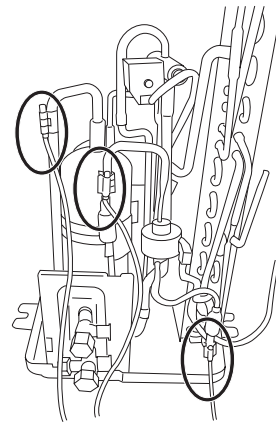

13) A nut is removed and a terminal cover is removed.



17) An outdoor fan is removed.

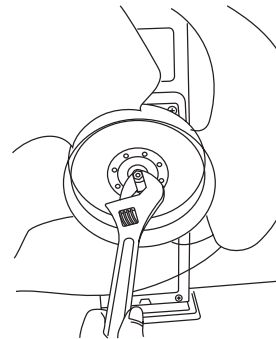

14) A lead wire, a thermistor, and a cover gasket are removed.



18) The fixed 2 screws of a motor angle is removed.

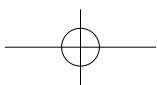
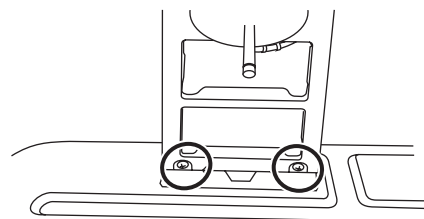



# CHAPTER 6. OPERATION MANUAL

## BASIC OPERATION

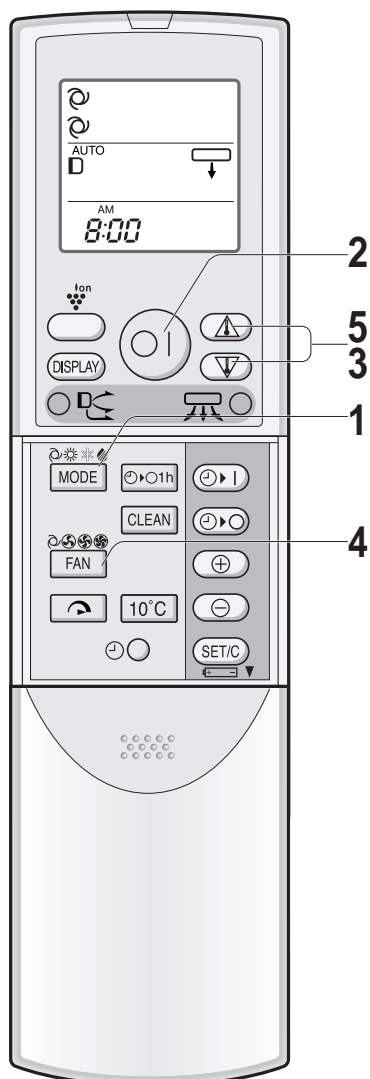

### 1 Press the **MODE** button to select the operation mode.

AUTO HEAT COOL DRY

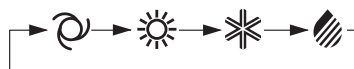

### 2 Press the **ON/OFF** button to start operation.

- The red OPERATION lamp (  ) on the unit will light.

### 3 Press the **THERMOSTAT** button to set the desired temperature.

#### **AUTO/DRY MODE**

- The temperature can be changed up to 2°C above or below the temperature automatically determined by the air conditioner.

(Example: 1°C higher)

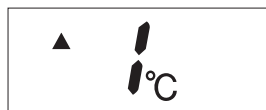

(Example: 2°C lower)



#### **COOL/HEAT MODE**

- The temperature can be set within the range of 18 to 32°C.

### 4 Press the **FAN** button to set the desired fan speed.

AUTO SOFT LOW HIGH



- In the DRY mode, the fan speed is preset to AUTO and cannot be changed.

### 5 To turn off the unit, press the **ON/OFF** button again.

- The red OPERATION lamp (  ) on the unit will turn off.

#### TIPS ABOUT AUTO MODE

In the AUTO mode, the temperature setting and mode are automatically selected according to the room temperature and outdoor temperature when the unit is turned on.

- During operation, if the outdoor temperature changes, the temperature settings will automatically slide as shown in the chart.

#### Modes and Temperature Settings

		0		10		18		28		34		outdoor temp. (°C)
indoor temp. (°C)	29	Heat (24°C)	Heat (23°C)	Dry (Room Temp. -2°C)		Cool (24°C)		Cool (25°C)		Cool (26°C)		
	21	Heat (22°C)										

The figures in ( ) are temperature settings

## TIPS ABOUT INDICATOR PANEL

The indicator panel will change each time you press the DISPLAY button in the following manner.

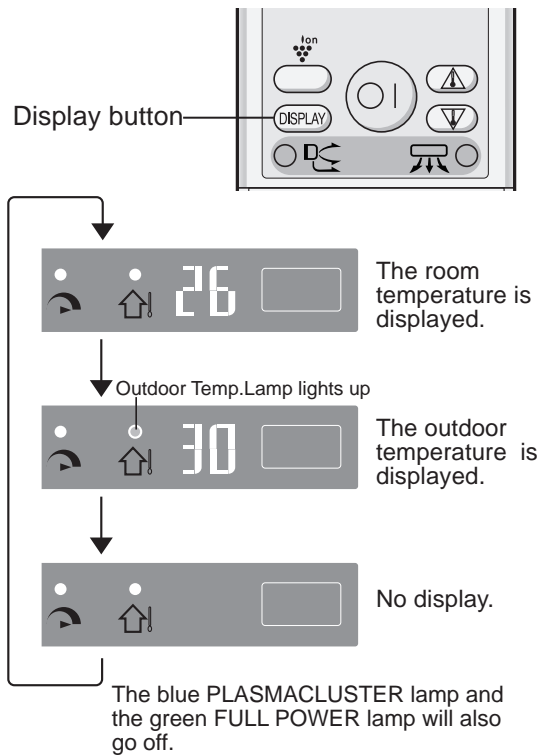

**NOTE:**

- The displayed temperatures are rough estimates and may vary from the actual temperatures.
- -- is displayed until the temperatures are being detected.
- Only the room temperature can be displayed for 5 seconds when the unit is not in operation.
- During SELF CLEAN operation, the indicator panel will display remaining time of the operation. Room and outdoor temperature will not be displayed even if you press the DISPLAY button.
- Temperature display ranges

Room temperature

Temperature Indicator	Room temperature
H i	Above 40°C
0~40	0°C~40°C
Lo	Below 0°C

Outdoor temperature

Temperature Indicator	Outdoor temperature
H i	Above 45°C
-19~45	-19°C~45°C
25~20*	-25°C~-20°C
Lo	Below -25°C

\*The minus symbol "-" is not displayed.

## FULL POWER OPERATION

In this operation, the air conditioner works at the maximum power to makes the room cool or warm rapidly.

**1 Press the FULL POWER button during operation.**

- The remote control will display "⏏".
- The temperature display will go off.
- The green FULL POWER lamp (⏏) on the unit will light up.

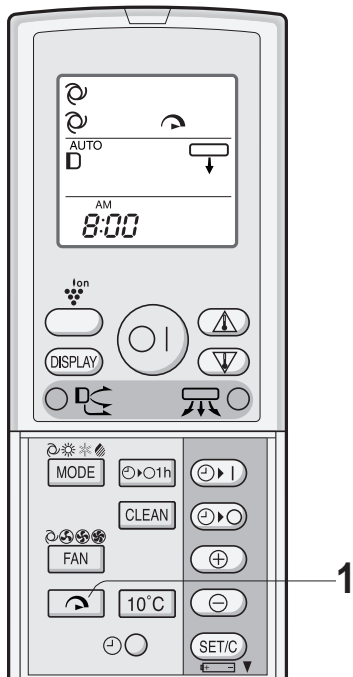

**TO CANCEL**

Press the FULL POWER button again.

- The green FULL POWER lamp (⏏) on the unit will turn off.

**NOTE:**

- You can not set the temperature or fan speed during the FULL POWER operation.
- FULL POWER operation will be automatically cancelled in one hour, and the unit return to the original settings. The green FULL POWER lamp (⏏) on the unit will turn off.

# ADJUSTING THE AIR FLOW DIRECTION

## VERTICAL AIR FLOW DIRECTION

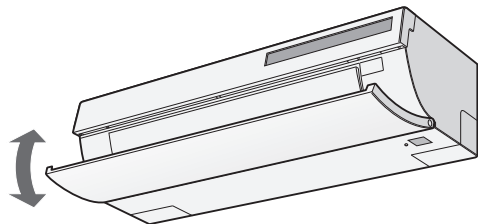

1 Press the VERTICAL AIR FLOW button to set the desired air flow direction.

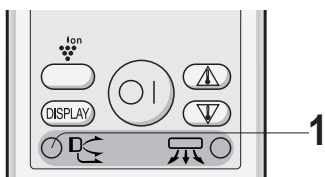

### AUTO mode

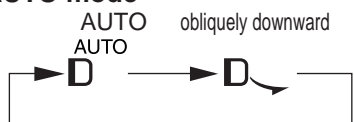

### HEAT mode

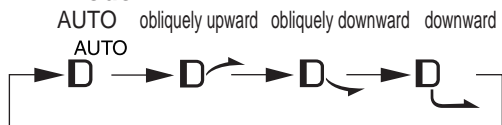

### COOL/DRY mode

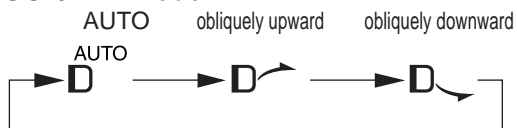

## HORIZONTAL AIR FLOW DIRECTION

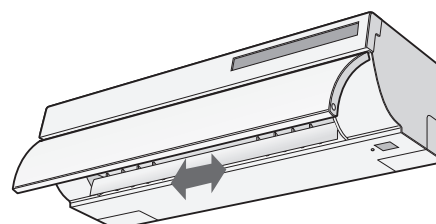

1 Press the HORIZONTAL AIR FLOW button to set the desired air flow direction.

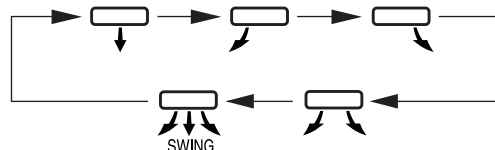
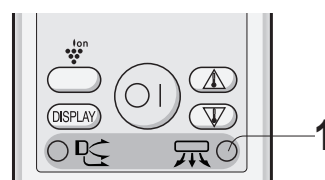

### CAUTION:

Never attempt to adjust the open panel and the louvres manually.

- Manual adjustment of the open panel and the louvres can cause the unit to malfunction.

## TIPS ABOUT AIR FLOW DIRECTION "AUTO"

### COOL mode

The open panel will be set obliquely downward for 10 minutes, and then shift to obliquely upward to deliver cool air to the ceiling.

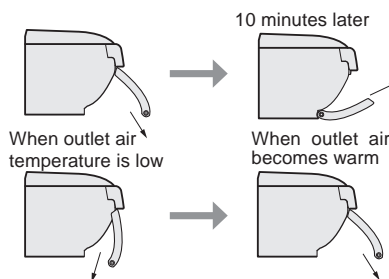

### HEAT mode

The open panel will be set obliquely backward when outlet air temperature is low, and then shift to obliquely downward when outlet air becomes warm.

### DRY mode

The open panel will be set obliquely upward.

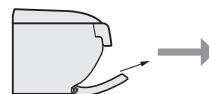

## PLASMACLUSTER OPERATION

Plasmacluster ions released into the room are effective against airborne contaminants, such as mold, viruses, and allergens.

### 1 During operation, press the PLASMACLUSTER button.

- The remote control will display “”.
- The blue PLASMACLUSTER lamp on the unit will light up.

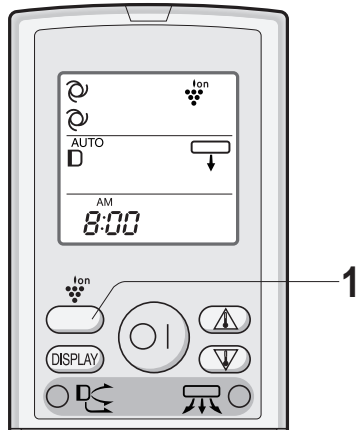

#### TO CANCEL

Press the PLASMACLUSTER button again.

- The PLASMACLUSTER lamp on the unit will turn off.

#### NOTE:

- Use of the PLASMACLUSTER operation will be memorized, and it will be activated the next time you turn on the air conditioner.
- To perform the PLASMACLUSTER operation in fan only mode, press the PLASMACLUSTER button while the unit is not operating. The mode symbol of the remote control will go off and the fan speed can not be set AUTO.

## SELF CLEAN OPERATION

SELF CLEAN operation will reduce the growth mold fungus with Plasmacluster ions and dry inside of the air conditioner unit. Utilize the operation at seasonal change over terms.

### 1 Press the SELF CLEAN button when the unit is not operating.

- The remote control displays “”.
- The blue PLASMACLUSTER lamp on the unit will light up.
- The unit will stop operation after forty minutes.
- The remaining operation time will be indicated on the TEMPERATURE INDICATOR of the indoor unit in minute decrements.

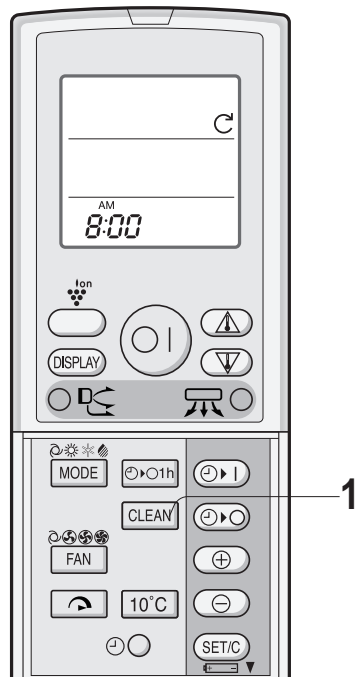

#### TO CANCEL

Press the SELF CLEAN button.

- The blue PLASMACLUSTER lamp on the unit will turn off.

#### NOTE:

- You cannot set the temperature, fan speed, air flow direction or timer setting during the SELF CLEAN operation.
- Mold fungus already grown can not be eliminated by this operation.

## ONE-HOUR OFF TIMER

When the ONE-HOUR OFF TIMER is set, the unit will automatically turn off after one hour.

### 1 Press the ONE-HOUR OFF TIMER button.

- The remote control displays “ $\text{1h}$ ”.
- The orange TIMER lamp (  $\text{1h}$  ) on the unit will light up.

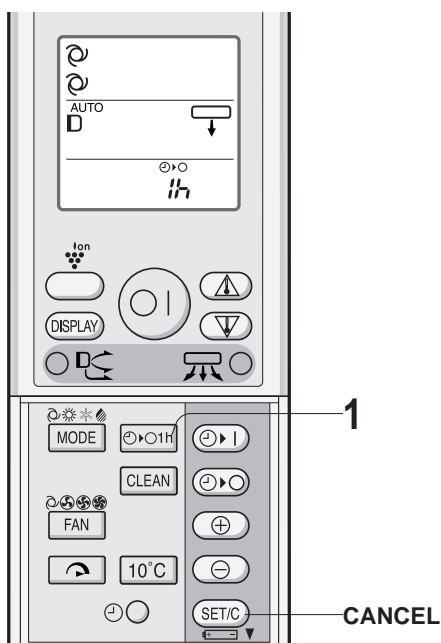

### TO CANCEL

Press the **TIMER CANCEL (SET/C)** button.

- The orange TIMER lamp (  $\text{1h}$  ) on the unit will turn off.

### NOTE:

- The ONE-HOUR OFF TIMER operation has priority over TIMER ON and TIMER OFF operations.
- If the ONE-HOUR OFF TIMER is set while the unit is not operating, the unit will operate for an hour at the formerly set condition.
- If you wish to operate the unit for another hour before the ONE-HOUR OFF TIMER is activated, press the ONE-HOUR OFF TIMER button again during operation.
- If TIMER ON and/or TIMER OFF are set, TIMER CANCEL button cancels every setting.

## TIMER OPERATION

Before setting the timer, make sure the clock is properly set with the current time.

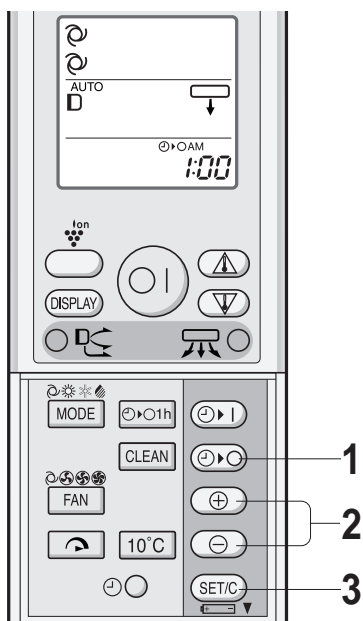

### TIMER OFF

- 1 Press the **TIMER OFF (  $\text{1h}$  )** button.
- 2 The **TIMER OFF** indicator will blink; press the **TIME ADVANCE** or **REVERSE** button to set the desired time.  
(The time can be set in 10-minute increments.)
- 3 Press the **TIMER SET (SET/C)** button.
  - The orange TIMER lamp (  $\text{1h}$  ) on the unit will light.

### TIPS ABOUT TIMER OFF OPERATION

When the TIMER OFF mode is set, the temperature setting is automatically adjusted to prevent the room from becoming excessively warm or cool, for example while you sleep. (Auto Sleep function)

#### COOL/DRY MODE:



- One hour after the time operation begins, the temperature setting rises 1°C higher than the original temperature setting.

#### HEAT MODE:

- One hour after the timer operation begins, the temperature setting drops 3°C lower than the original temperature setting.

## TIMER OPERATION

### TIMER ON

- 1 Press the **TIMER ON** (  ) button.
- 2 The **TIMER ON** indicator will blink; press the **TIME ADVANCE** or **REVERSE** button to set the desired time.  
(The time can be set in 10-minute increments.)
- 3 Press the **TIMER SET (SET/C)** button.
  - The orange **TIMER** lamp (  ) on the unit will light.
- 4 Select the operation condition.

#### NOTE:

- The unit will turn on prior to the set time to allow the room to reach the desired temperature by the programmed time. (Awaking function)

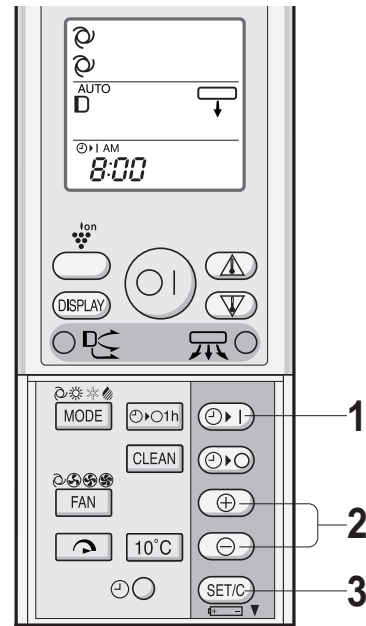

### TO CANCEL TIMER MODE

Press the **TIMER CANCEL (SET/C)** button.

- The orange **TIMER** lamp (  ) on the unit will turn off.
- The current clock time will be displayed on the remote control.

#### NOTE:

- If any **TIMER ON**, **TIMER OFF** and **ONE-HOUR OFF TIMER** are set, the **TIMER CANCEL** button cancels all settings.

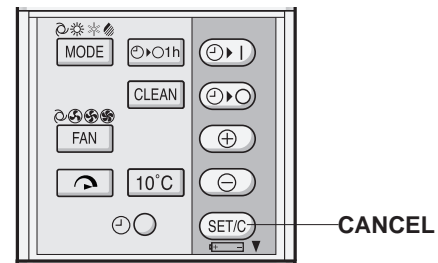

### TO CHANGE TIME SETTING



Cancel the **TIMER** setting first, then set it again.

### COMBINED USE OF ON AND OFF TIMERS

You can use the **ON** and **OFF** timers in combination.

#### Example:

To stop operation at 11:00 p.m. and resume operation to bring the room temperature to the desired level by 7:00 a.m.

- 1 Set the **TIMER OFF** to 11:00 p.m. during operation.
- 2 Set the **TIMER ON** to 7:00 a.m.  
The arrow (  or  ) between the **TIMER ON** indicator and the **TIMER OFF** indicator shows which timer will activate first.

#### NOTE:

- You cannot programmed the **ON-TIMER** and **OFF-TIMER** to operate the unit at different temperatures or other settings.
- Either timer can be programmed to activate prior the other.

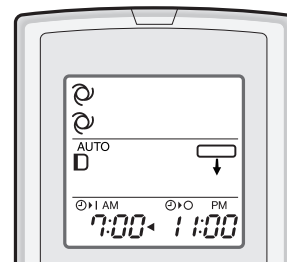

## 10°C OPERATION

Heating operation with 10°C set temperature will be performed.

- 1 Press the **MODE** button and select **HEAT** mode.
- 2 Press the **ON/OFF** button to start **HEAT** operation.
- 3 Press the **10°C** button.
  - The remote control will display "10°C".

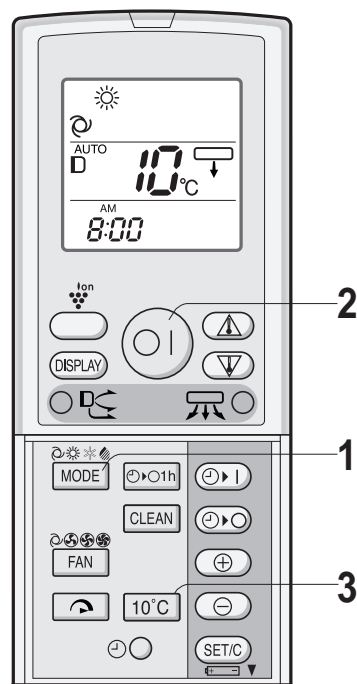

### TO CANCEL

Press the **10°C** button again.

### NOTE:

- 10°C operation will not be available with heating operation automatically selected by **AUTO** mode.

## AUXILIARY MODE

Use this mode when the remote control is not available.

### TO TURN ON

Press the **AUX** button.

- The red **OPERATION** lamp (  ) on the unit will light and the unit will start operating in the **AUTO** mode.
- The fan speed and temperature setting are set to **AUTO**.

### TO TURN OFF

Press the **AUX** button again.

- The red **OPERATION** lamp (  ) on the unit will turn off.

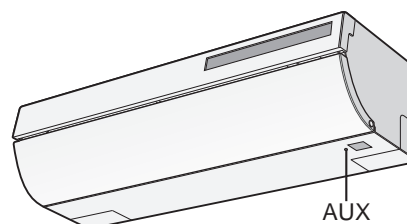

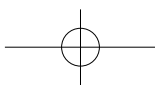
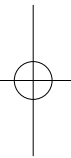
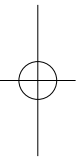
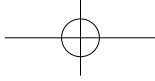











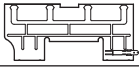
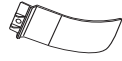

## CHAPTER 7. INSTALLATION MANUAL

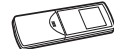
### SAFETY PRECAUTIONS

- **Installation must be made in accordance with the installation manual by qualified service personnel.**  
Incorrect work will cause electric shock, water leak, fire.
- **Be sure to use the attached accessories parts and specified parts for installation.**  
Use of other parts will cause electric shock, water leak, fire, the unit falling.
- **The appliance shall be installed in accordance with national wiring regulations.**  
Wrong connection can cause overheating or fire.
- **After installation has complete, check that there is no leakage of refrigerant gas.**  
If the refrigerant gas contact with fire, it may generate toxic gas.
- **Ventilate the room if refrigerant gas leaks during installation.**  
If the refrigerant gas contact with fire, it may generate toxic gas.
- **Use the specified electrical cable.**  
Make sure the cable is secured in place and that the terminals are free of any excess force from the cable. Otherwise overheating or fire may result.
- **Form the cable so that the control box cover, the cord holder and cable holder are not loose.**  
Otherwise overheating, fire or electric shock may result.
- **Tighten the flare nut with a torque wrench according to the specified method.**  
If the flare nut is tightened too hard, the flare nut may be broken after a long time and cause refrigerant gas leakage.
- **When installing the unit, take care not to enter air substance other than the specified refrigerant(R410A) in the refrigerant cycle.**  
Otherwise, it will cause burst and injury as a result of abnormal high pressure in the refrigerant cycle.
- **Be sure to connect the refrigerant pipe before running the compressor.**  
Otherwise, it will cause burst and injury as a result of abnormal high pressure in the refrigerant cycle.
- **Earth the unit.**  
Incomplete earth may cause electrical shock.
- **If national legislations or type of installation requires earth leakage breaker, the legislation must be followed.**
- **Arrange the drain hose to ensure smooth drainage.**  
Insufficient drainage may cause wetting of the room, furniture etc.
- **This room air conditioner uses refrigerant R410A.**  
Use the pipe, flare nut and tools exclusively for R410A.

### ACCESSORIES

ITEMS	Q'ty	APPLICATION	ITEMS	Q'ty	APPLICATION
<b>1 MOUNTING PLATE</b> 	1	To mount the indoor unit on the wall.	<b>7 TERMINAL COVER</b> 	1	To cover the electrical cable.
<b>2 WALL PLUG</b> 	8	To fix the mounting plate with the long screws. (7) To fix the remote control with the special screw. (1)	<b>8 SHORT SCREW (M4x25)</b> 	3	To secure the terminal cover. (1) To fix the indoor unit on the mounting plate. (2)
<b>3 LONG SCREW (M4.5x30)</b> 	7	To fix the mounting plate with the wall plugs.	<b>9 DROPPER</b> 	1	To check the drainage.
<b>4 REMOTE CONTROL</b> 	1	To control remotely.	<b>10 MANUALS</b> 	1	Installation manual
<b>5 DRY BATTERY</b> 	1	For the remote control. AAA batteries.	<b>11 AIR PURIFYING FILTER</b> 	2	To remove dust and tobacco smoke from the air.
<b>6 SPECIAL SCREW (M4x20)</b> 	1	To mount the remote control on the wall.	<b>12 SHEET(adhesive type)</b> 	1	To firmly secure the electrical cable.

### NOTES ON LOCATIONS

#### Indoor unit

1. Keep the air outlet clear of any obstacle so that outgoing air flows smoothly in the entire room.
2. Make a drain hose hole for easy drainage.
3. Provide sufficient space on both sides and above the unit.
4. The air filters should be easily taken in and out.
5. Keep TV set, radio and the like 1 m or more away from the unit and the remote control.
6. Keep the air inlet clear of obstacles that could block incoming air.
7. The remote control may not function properly in a room equipped with an electronic simultaneous-start or rapid-start fluorescent lighting.
8. Select a location that does not cause loud operation noise and extreme vibrations.

#### Outdoor unit

1. Place the outdoor unit on a stable base.
2. Provided sufficient space around the unit. It should also be well ventilated.
3. The unit should not be exposed to strong wind nor splashed with rain water.
4. Water drain from the unit should be let out without problem. Lay a drain hose if required. In cold regions, installation of the drain pipe is not advisable as freezing could result.
5. Keep TV set, radio and the like 1 m or more away from the unit.
6. Avoid locations exposed to machine oil vapor, salty air (facing the seashore, for example), hot spring vapor sulfur gas, etc. Such location can cause breakdown.
7. Also, avoid locations exposed to muddy water (along a road, for example) or where the unit can be tampered with.
8. Select a location where the outgoing air or operating noise cannot annoy others.
9. Keep the air outlet opening free of any obstacle. This could affect the performance of the unit and create loud noises.

# PIPING

Max. piping length:A	Max. height difference:B	Min. piping length	Additional refrigerant (piping length exceeds 10m)
15 m	7 m	1 m	20 g/m

- Standard piping length is 5m.
- When the outdoor unit is placed at a higher level than the indoor unit, provide a trap near the hose's lead-in port.

Use the refrigerant pipes shown in the table below.

Pipe size	Pipe thickness	Thermal insulation
Liquid side	1/4" (ø 6.35 mm)	Thickness: 6 mm or thicker Material: Polyethylene foam
Gas side	3/8" (ø 9.52 mm)	

- The thermal insulation should cover both the gas and liquid pipes.

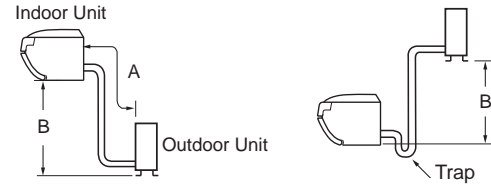

# INSTALLATION DIAGRAM

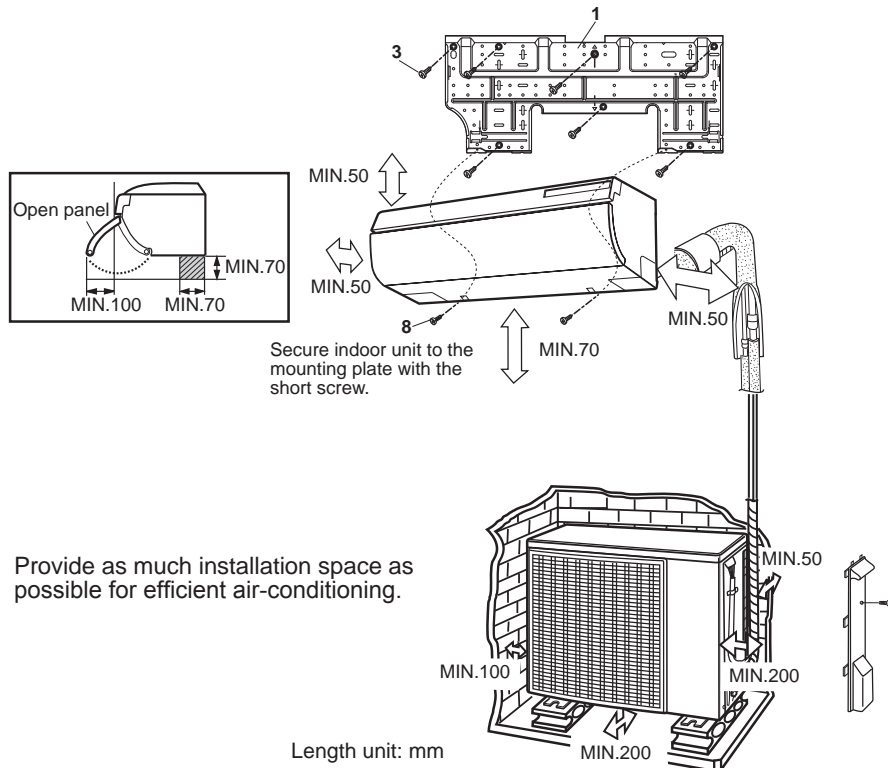

# NOTES ON DRAIN HOSE

The drain hose can be connected at either side of the indoor unit.

Reposition the drain hose and drain cap as required.

- (1) Remove the fixed screw in the hose holder at the end of the drain hose.
- (2) Hold the end of the drain hose, and pull it out.
- (3) Pull out the drain cap.
- (4) Reconnect the drain hose to the right and insert the drain cap to the left.
  - Fully insert the drain hose until it stops and use the screw that was previously removed in STEP(1) to secure the hose holder to the drain pan.
  - Insert a hexagon socket screw key (4 mm diagonal) into the drain cap, and press it fully.

**Caution:**

After replacing, make sure that both the drain hose and drain cap are firmly inserted.

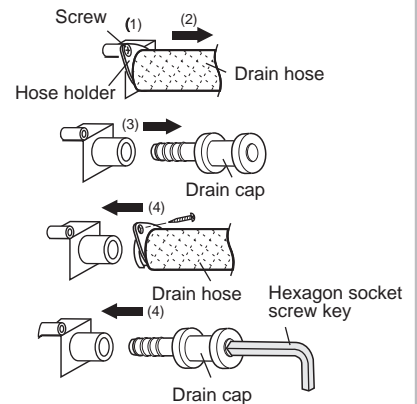
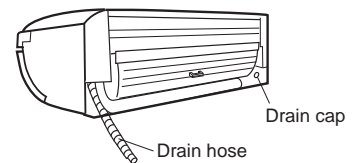

# 1

## PLACING THE MOUNTING PLATE AND MAKING A PIPING HOLE

- (1) Referring to the figure below, mark the location for the wall plugs and the piping hole.
- Recommended fixing holes are marked in circle around the hole. (7 points)
  - Make sure that the mounting plate is horizontally.

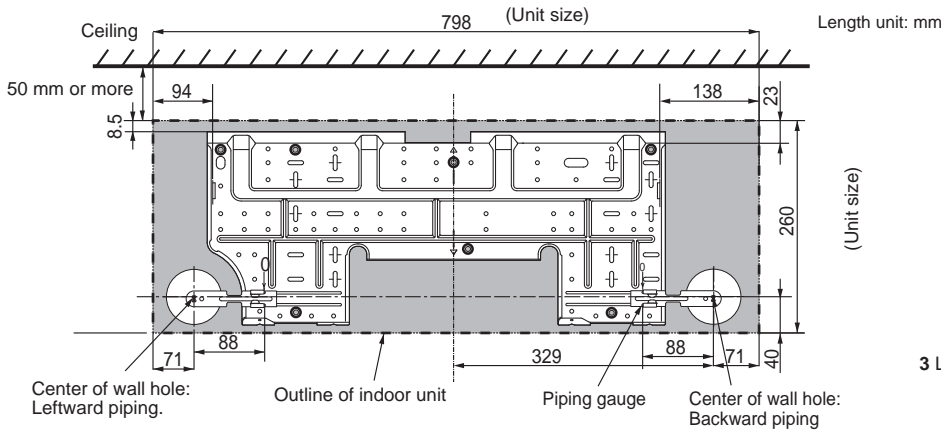

### Determining hole position

1. Slide the piping gauge toward the piping hole. Make sure that the stopper is fit to the "0" position on the mounting plate.
2. Mark the center of hole on the wall by pushing the end of the piping gauge.
3. Replace the piping gauge

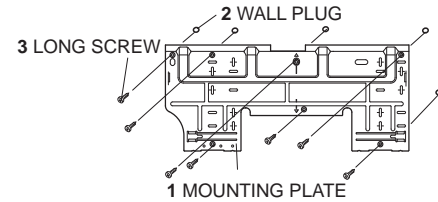
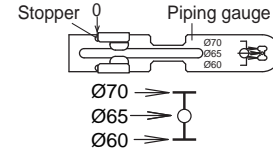

- (2) Drill diameter 6.5 mm, depth 32 mm holes and fit the wall plug.
- (3) Secure the mounting plate to the wall with the long screws and check the stiffness.
- (4) Drill a piping hole with 70 mm diameter concrete drill or a hole saw with a 5 mm down ward slant to the outside.
- (5) Set the sleeve and caps.

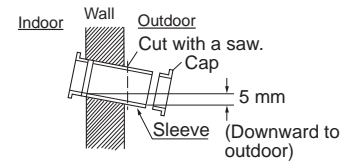
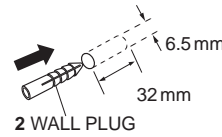

# 2

## SETTING UP THE INDOOR UNIT

### Piping route

For directions 1, 2, 4 and 5, cut out the specific zone without leaving any sharp edge.

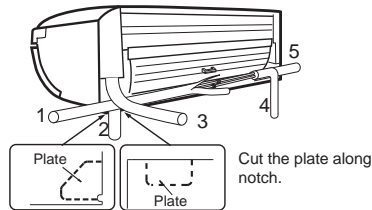

### Panel cover

Installation is easily achieved by removing the panel cover.

#### Removal

Remove the panel cover by pushing arrow-marked points.

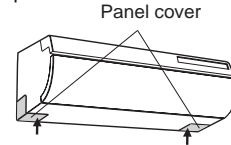

#### Attachment

Fit the side of the panel cover to the unit, and fit in the bottom of the panel cover to the unit.

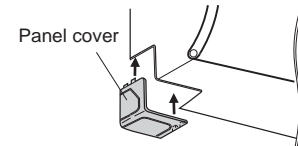

### Mounting the indoor unit

#### For right side piping

- (1) Pass the pipes and the drain hose through the piping hole.
- (2) Hook the unit onto the mounting plate.
- (3) Pull the connecting cable into the indoor unit.
- (4) Push the unit and apply the bottom hooks to the mounting plate's support.
- (5) Pull the bottom of the unit to check that the unit is fixed in place.

#### For left side piping

- (1) Reverse the positions of the drain hose and drain cap. Refer to NOTES ON DRAIN HOSE.
- (2) Connect the pipes and connecting cable.
- (3) Bind the pipes and connecting cable with tape.
- (4) Set the them along the back of the unit, and attach the piping holder.
- (5) Pass the pipes, connecting cable and the drain hose through the piping hole.
- (6) Hook the unit onto the mounting plate.
- (7) Push the unit and apply the bottom hooks to the mounting plate's support.
- (8) Pull the bottom of the unit to check that the unit is fixed in place.

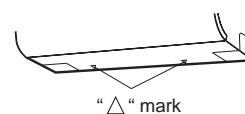
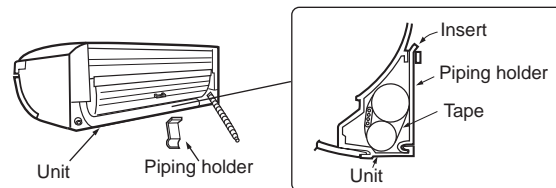
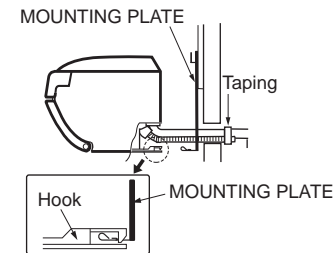

### Detaching the unit from the mounting plate

Push the "△" marks at the bottom of the indoor unit and pull the bottom of the unit. When the hooks are released from the mounting plate, support the bottom of the unit and lift the unit upwards.

### 3 CONNECTING THE CABLE TO THE INDOOR UNIT

- Process the end of the connecting cable for the indoor side.
  - Use a copper cable. (Cross-section area 1,5 mm<sup>2</sup>)
  - Use a cable which is not lighter than polychloroprene sheathed flexible cord (code designation 60245 IEC 57).

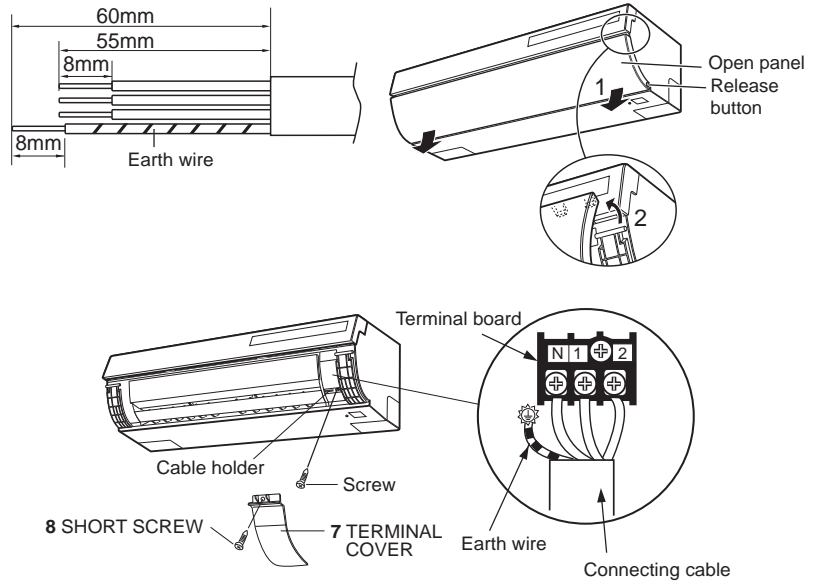

- Remove the open panel.
  - Push the release button and open the lower part of the open panel.
  - Lift the open panel up slightly and remove it.
- Unscrew the screw and release the cable holder.
- Connect the cable.
  - Be very careful not to confuse the terminal connections. Wrong cabling may damage the internal control circuit.
  - The markings on the indoor unit's terminal board must match with those of the outdoor unit.
- Fasten the cable with the cable holder and the screw.
- Attach the terminal cover with the short screw.
- Replace the open panel.

### 4 CONNECTING THE DRAIN HOSE

#### Connecting the drain hose

- Connect a drain hose.
- Tape over the connecting part.

#### Notes:

- Be sure to lay the drain hose downward for smooth drainflow.
- Be careful not to allow the drain hose to rise, form a trap or leave its end in water, as shown below.
- Coil thermal insulation around a drain hose extension, if running in the room.

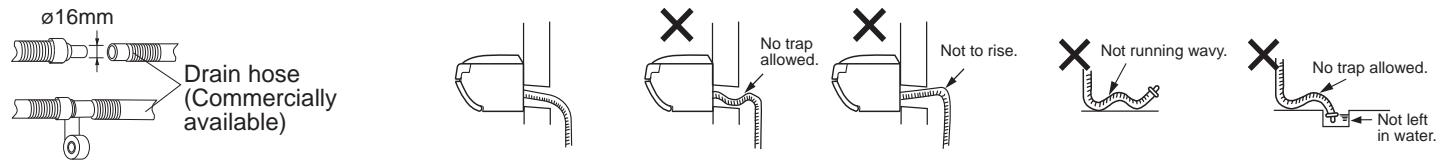

#### Checking drainage

- Remove the open panel.
- Remove the drain cover with a slotted screwdriver.
- Pour some water into the drain hole with the dropper.
- Check the water drains smoothly.
- Replace the drain cover.
- Replace the open panel.

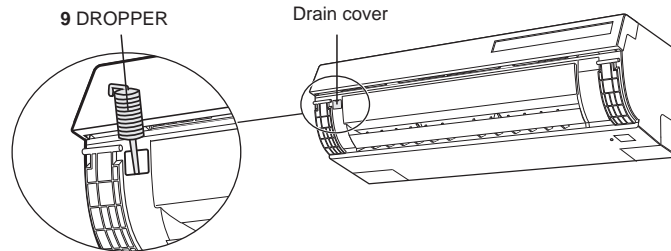

### 5 OUTDOOR UNIT INSTALLATION

Referring to the figure, firmly fasten the outdoor unit with bolts.

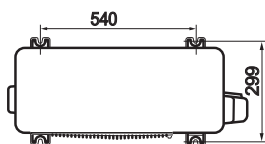

### 6 CONNECTING THE REFRIGERANT PIPES

#### Flaring the pipe end

- Cutting with a pipe cutter. Cut at a right angle.
- Deburring. Allow no cuttings in the pipe.
- Putting in the flare nut.
- Flaring. Flare processing dimensions(A).

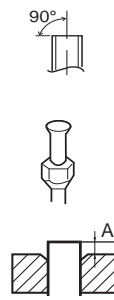

Tool	A
R410A tool	0 - 0.5 mm
Conventional tool	1.0 - 1.5 mm

- Checking. To be flared perfectly circular. Flare nut not missing.

#### Connecting the pipes

Connect the pipes for the indoor unit first and then for the outdoor unit.

- Tighten the flare nuts by hand for the first 3-4 turns.
- Use a wrench and torque wrench to tighten up the pipes.
  - Do not over tighten the pipes. It may be deformed or damaged.

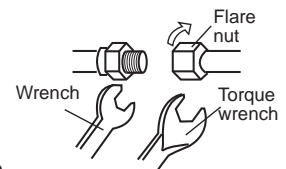

#### Flare nut tightening torque

Pipe size		Torque
Liquid side	1/4" (ø 6.35 mm)	16±2 N·m (1.6±0.2 kgf·m)
Gas side	3/8" (ø 9.52 mm)	38±4 N·m (3.8±0.4 kgf·m)

## 7 AIR REMOVAL

Use a vacuum pump, gauge manifold and hoses exclusively for R410A.

- (1) Remove both valve shaft caps of the 2 and 3-way valves.
- (2) Remove the service port cap of the 3-way valve.
- (3) Connect the gauge manifold hose to the service port and the vacuum pump.  
Be sure that the hose end to be connected to the service port has a valve core pusher.
- (4) Open the gauge manifold low-pressure valve (Lo) and operate the vacuum pump for 10-15 minutes.  
Make sure the compound gauge reads  $-0.1$  MPa ( $-76$  cmHg).
- (5) Close the gauge manifold valve.
- (6) Turn off the vacuum pump.  
Leave as it for 1-2 minutes and make sure the needle of the compound gauge does not go back.
- (7) Open the 2-way valve  $90^\circ$  counterclockwise by turning the hexagon wrench. Close it after 5 seconds, and check for gas leakage.\*
- (8) Disconnect the gauge manifold hose from the service port.
- (9) Fully open the 2-way valve with hexagon wrench.
- (10) Fully open the 3-way valve with hexagon wrench.
- (11) Firmly tighten the service port cap and both valve shaft caps with a torque wrench at the specified tightening torque.

\* Check the pipe connections for gas leak using a leakage detector or soapy water. Regarding leakage detector, use high-sensitivity type designed specially for R410A.

\* If a high pressure test is mandatory in your country, make sure to follow the local legislation.

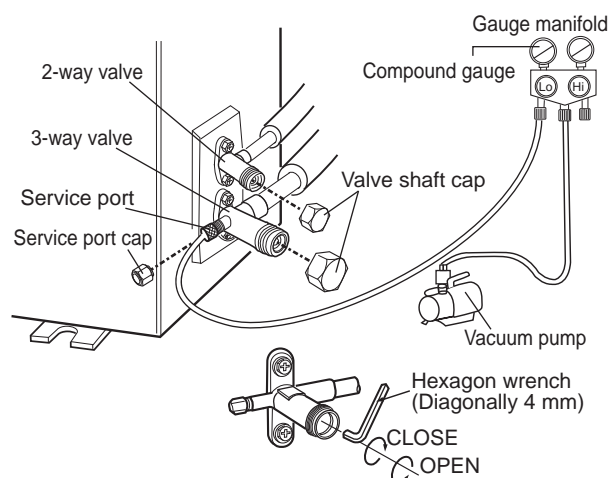

### Valve shaft cap tightening torque

Pipe size		Torque
Liquid side	1/4"	$24 \pm 3$ N · m ( $2.4 \pm 0.3$ kgf · m)
Gas side	3/8"	$24 \pm 3$ N · m ( $2.4 \pm 0.3$ kgf · m)

### Service port cap tightening torque

Torque
$11 \pm 1$ N · m ( $1.1 \pm 0.1$ kgf · m)

## 8 CONNECTING THE CABLE TO THE OUTDOOR UNIT

- (1) Process the end of the connecting cable and the power supply cable for the outdoor unit.

- Use a copper cable.

	Cross-section area
Unit-to-unit cable	$1.5$ mm <sup>2</sup>
Power supply cable	$1.5$ mm <sup>2</sup> ( $2.5$ mm <sup>2</sup> in case the cable length exceeds 20m)

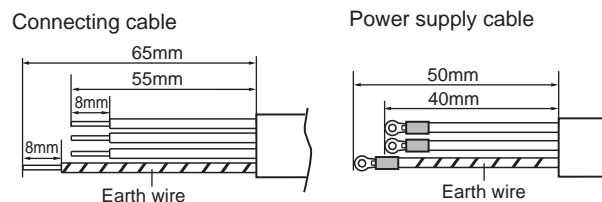

- For power supply cable, securely clamp a round terminal to each end of the stripped cable.
- Use a cable which is not lighter than polychloroprene sheathed flexible cord (code designation 60245 IEC 57).

- (2) Remove the control box cover.
- (3) Remove the cable holder and connect the cables.  
Be sure that the terminal connections are as specified.
- (4) Fix the cable sheaths with the cable holder and the screw.
- (5) Double-check that the cables are securely in place.
- (6) Place the control box cover back in the reverse order.

\*If the cable sheaths are not firmly secured with the cable holder, put the SHEET on the cable holder base.

### Caution:

- Be sure to put the cable leads deep into the terminal board and tighten up the screws. Poor contact can cause overheating or fire, or malfunction.

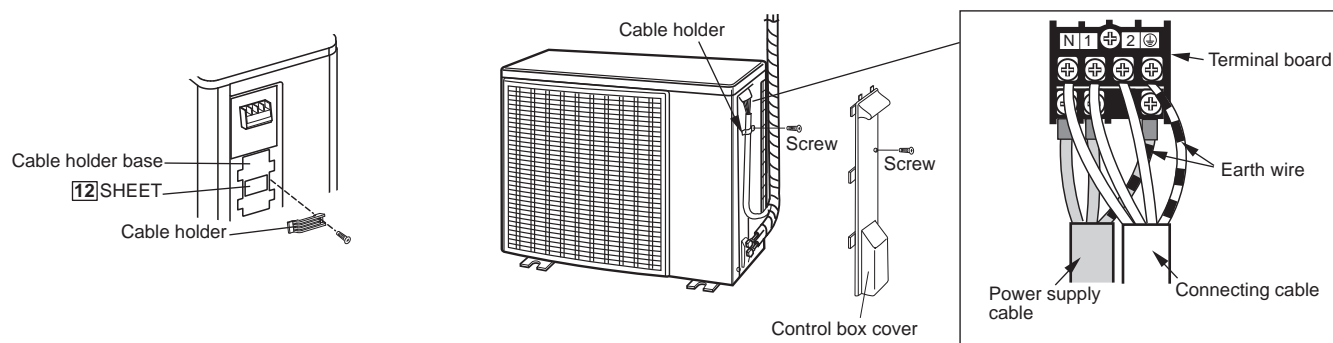

## 9 POWER CABLING

Prepare a dedicated power supply circuit.

Supply power	220 V - 240 V, single-phase
Circuit breaker	10 A

- Fit a disconnect switch, having a contact separation of at least 3mm in all poles, to the electricity power line.

## 11 TEST RUN

- (1) Start the operation with the remote control.
- (2) To start test run in cooling, hold down the AUX button on the unit for over 5 seconds until a beep sound is heard and an operation lamp flashes.
- (3) To put the system in the heating test run mode, select heat mode on the remote control while the unit is in cooling test run mode.
- (4) Make sure the system runs well. To stop the operation, press the AUX button again.

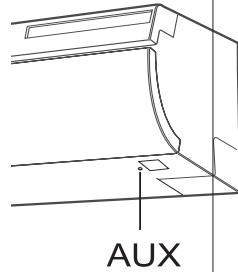

## 10 HANGING THE REMOTE CONTROL

- (1) Fit the special screw to the wall with the wall plug.
- (2) Hang the remote control to the screw head.

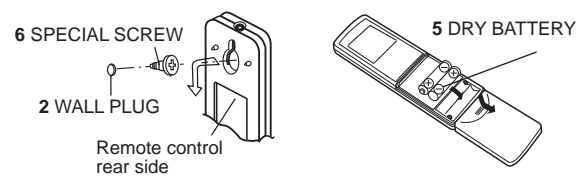

## 12 ITEMS TO CHECK

- Is the specified power supply voltage used?
- Is the connecting cable fixed to terminal board firmly?
- Is the earth wire connected properly arranged?
- Is the drainage properly?
- Is the indoor unit hooked to the mounting plate firmly?
- Is there any gas leakage at the pipe connection?

### Explanation to customer

- Explain to the customer how to use and maintain the system, referring to the operation manual.
- Ask the customer to carefully read the operation manual.
- When the system has been set up, hand the installation manual to the customer.

## FRONT PANEL - REMOVAL AND ATTACHMENT

When servicing, for example, use the following procedure to detach/attach the front panel. Disconnect the power or shut off the breaker before implementation.

### Removal

- (1) Remove the open panel.
  1. Push the release button and open the lower part of the open panel.
  2. Lift the open panel up slightly and remove it.
- (2) Open the filter cover
- (3) Remove the wire cover with a slotted screwdriver.
- (4) Remove the nine connectors.
- (5) Remove the front panel.
  1. Unscrew the four screws on the front panel.
  2. Release the three hooks along the upper surface.

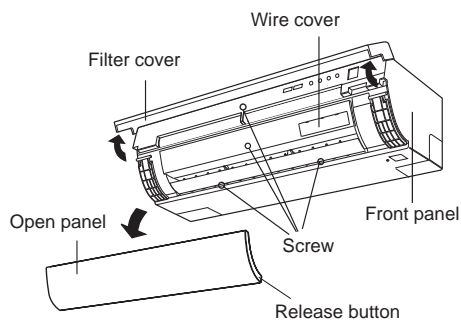

### Attachment

- (1) Replace the front panel
  1. Insert the three hooks along the upper surface into the unit.
  2. Push the bottom of the front panel to the unit.
  3. Tighten the four screws on the front panel.
- (2) Connect the nine connectors.
- (3) Replace the wire cover.
- (4) Close the filter cover.
- (5) Replace the open panel.
  1. Hook both tabs on the shaft.
  2. Close the open panel.

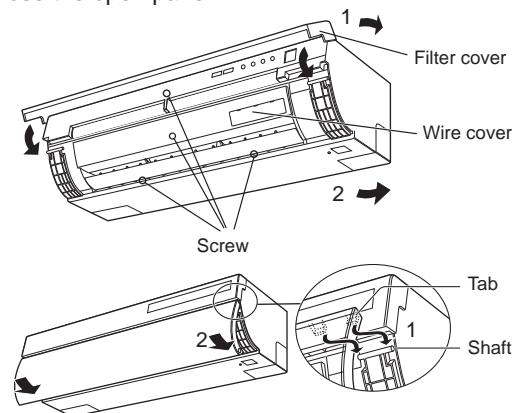

## PUMP DOWN (Pump down is adopted in the case of unit removal for re-installation, abandonment, repair etc.)

Pump down is to collect the refrigerant into the outdoor unit by control of the 2 and 3-way valves and the compressor.

- (1) Stop the air conditioner operation.
- (2) Remove both valve shaft caps of the 2 and 3-way valves.
- (3) Run the air conditioner at cooling test run mode (Refer to 11 TEST RUN). If pump down is performed at normal cooling operation, the protection system may engage and stop the operation.
- (4) After 5~10 minutes, fully close the 2-way valve by turning the hexagon socket screw key clockwise.
- (5) After 2~3 minutes, immediately close the 3-way valve fully.
- (6) Stop the test run operation.
- (7) Replace both valve shaft caps tightly.
- (8) Disconnect both refrigerant pipes.

### Caution:

Make sure that the compressor is turned off before removing the refrigerant pipes. Otherwise, it will cause burst and injury

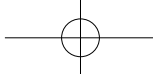

# PARTS LIST

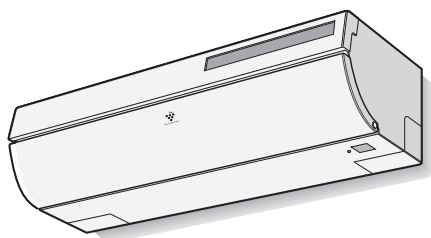

MODEL **12PHR-N**

In the interests of user-safety (Required by safety regulations in some countries) the set should be restored to its original condition and only parts identical to those specified should be used.

## CONTENTS

[1] INDOOR UNIT PARTS

[2] Panel opening and shutting mechanism R Assembly

[3] Panel opening and shutting mechanism L Assembly

[4] ACCESSORY PARTS

[5] OTHER PARTS

[6] INDOOR PACKING PARTS

[7] OUTDOOR UNIT PARTS

[8] OTHER PARTS

[9] OUTDOOR PACKING PARTS

■ INDEX

Parts marked with "△" are important for maintaining the safety of the set. Be sure to replace these parts with specified ones for maintaining the safety and performance of the set.

This document has been published to be used for after sales service only.  
The contents are subject to change without notice.

# [1] INDOOR UNIT PARTS

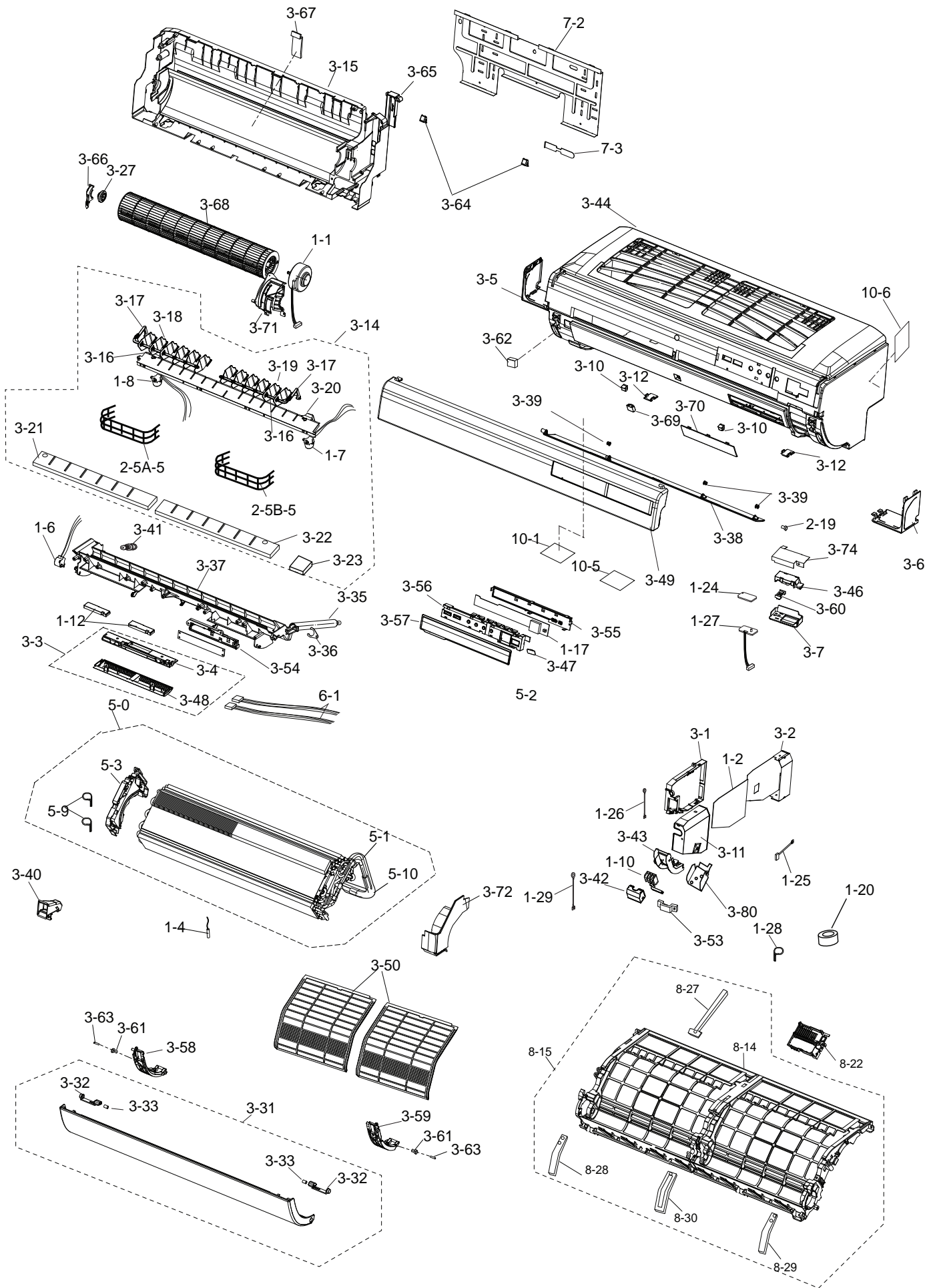



NO.	PARTS CODE	PRICE RANK	NEW MARK	PARTS RANK	Q'TY USED PER MODEL	DESCRIPTION
<b>[1] INDOOR UNIT PARTS</b>						
1-1	CMOT-A515JBKZ	BF			1	FAN MOTOR SUB ASS'Y
1-2	DSGY-F268JBKZ		N		1	CONTROL BOARD UNIT
1-4	RH-HXA113JBZZ	AG			1	THERMISTOR
1-6	RMOT-A174JBZZ	AK			1	LOUVER MOTOR H
1-7	RMOT-A179JBZZ	AK			1	LOUVER MOTOR VR
1-8	RMOT-A176JBZZ	AK			1	LOUVER MOTOR VL
1-10	QTANZA054JBZZ	AH			1	TERMINAL BOARD 3P
1-12	CKITTA125AKKZ	BF			2	PLASUMA CLUSTER UNIT
1-17	FSGY-A709JBKZ	BB			1	DISPLAY BOARD UNIT
1-20	RNF--A001VBE0	AE			1	FERRITE CORE
1-24	FSGY-A583JBKZ				1	SWITCH C-B-U
1-25	QW-VZG044JBZZ	AG			1	LEAD WIRE
1-26	QW-VZF948JBZZ	AD			1	LEAD WIRE
1-27	DSGY-C403JBKZ				1	SENSOR UNIT
1-28	LBND-A014JBE0	AB			9	FIXING BAND
1-29	QW-VZG165JBZZ	AE			1	LEAD WIRE
2-19	XTPS723P10000				1	SCREW
2-5A-5	GGAD-A069JBTA	AN			1	WIRE GUARD
2-5B-5	GGAD-A072JBTA	AN			1	WIRE GUARD R
3-1	PBOX-A515JBFZ	AM			1	CONTROL BOX
3-2	PCOV-B475JBWZ	AN			1	CONTROL BOX COVER
3-3	CCOV-A255JBKZ	AE			1	CLUSTER COVER ASS'Y
3-4	LHLD-A944JBFB	AE			1	CLUSTER HOLDER
3-5	PCOV-B501JBFA	AD			1	FRONT PANEL COVER L SE
3-6	PCOV-B502JBFA	AD			1	FRONT PANEL COVER R SE
3-7	PCOV-B467JBFA	AC			1	COVER
3-10	DCOV-A327JBKZ	AD			2	SCREW COVER K[PANEL SIDE]
3-11	PCOV-B476JBWZ	AG			1	TERMINAL COVER
3-12	PCOV-B503JBFB	AC			2	SCREW COVER[CABINET SIDE]
3-14	CDAI-A046JBKZ	AZ			1	V-LOUVER BASE ASS'Y
3-15	DCHS-A638JBKZ	AY			1	CABINET DK
3-16	MJNTPA150JBFB	AD			2	V-LOUVER-JOINT
3-17	MJNTPA155JBFA	AD			2	LOUVER LINK
3-18	MLOV-A501JBFB	AF			5	V-LOUVER-A
3-19	MLOV-A502JBFB	AF			7	V-LOUVER-B
3-20	PDAI-A231JBFA	AG			1	LOUVER BASE
3-21	PFPFPD504JBEZ	AC			1	INSULATOR A
3-22	PFPFPD505JBEZ	AC			1	INSULATOR B
3-23	PFPFPD549JBEZ	AA			1	LOUVER INSULATOR C
3-27	CHLD-A139JBKZ	AF			1	BEARING ASS'Y
3-31	CPNL-A631JBKZ	AY			1	PANEL ASS'Y
3-32	JBTN-A012JBFA	AD			2	PANEL BOTTOM
3-33	MSPR-A188JBEZ	AC			2	SPLING
3-35	PHOS-A052JBEZ	AG			1	DRAIN HOSE
3-36	LPLT-A058JBPZ	AC			1	HOSE HOLDAR

NO.	PARTS CODE	PRICE RANK	NEW MARK	PARTS RANK	Q'TY USED PER MODEL	DESCRIPTION
3-37	CSRA-A715JBKZ	AY			1	DRAIN PAN SUB ASS'Y
3-38	MLOV-A503JBFB	AF			1	AIR FLOW LOUVER H-LOUVER IN
3-39	NBRG-A038JBFA	AB			1	BEARING C
3-40	PGID-A166JBFA	AC			1	DRAIN GUIDE
3-41	PGUMMA381JBEZ	AC			1	DRAIN PLUG
3-42	PCOV-B477JBWZ	AD			1	COVER
3-43	PDAI-A218JBFA	AK			1	HOLDER
3-44	CWAK-C834JBKZ	BN			1	FRONT PANEL ASS'Y
3-46	LHLD-A879JBFA	-			1	HOLDER
3-47	PCOV-B381JBFA	-			1	COVER
3-48	PCOV-B526JBFB	AE			1	COVER
3-49	HPNL-B019JBRA	AN			1	FILTER COVER
3-50	PFILMA249JBEA	AL			2	AIR FILTER
3-53	LHLD-A956JBFA	AD			1	COAD HOLDER
3-54	LHLD-A960JBFZ	AD			1	HOLDER
3-55	LHLD-A933JBFA	AF			1	LED HOLDER
3-56	PCOV-B533JBFA	AH			1	LED GUIDE
3-57	HDECQA231JBRA	AR			1	DISPLAY PANEL
3-58	LHLD-A945JBFB	AE			1	PANEL
3-59	LHLD-A946JBFB	AE			1	PANEL BASE R
3-60	LHLD-A948JBFA	AC			1	SW BUTTON
3-61	LPIN-A010JBEZ	AA			2	PIN C
3-62	PFTA-A125JBFB	AB			1	COVER
3-63	XPSSJ20-12000	AB			2	SPRING PIN
3-64	PCOV-B521JBFA	AD			2	COVER S
3-65	LHLD-A394JBFA	AC			1	PIPE HOLDER
3-66	LHLD-A947JBFZ	AC			1	BEARING SUPPORT
3-67	LHLD-A951JBFA	AC			1	PIPE HOLDER
3-68	NFANCA116JBEZ	AT			1	CROSS FLOW FAN
3-69	PCOV-B525JBFB	AC			1	COVER B (for screws)
3-70	PFTA-A124JBFB	AD			1	COVER
3-71	PPLT-A661JBFZ	AF			1	SIDE COVER R
3-72	DCOV-A293JBKZ	AF			1	COVER ASS'Y
3-74	PSHE-A294JBEZ	AC			1	SHEET
3-80	PDAI-A240JBWZ	AF			1	PLATE
10-1	TSPC-J081JBRZ	AC		N	1	NAME LABEL
10-6	TLABCC631JBRZ	AB			1	WIRING DIAGRAM
5-0	DEVA-A407JBKZ	BP			1	EVAPORATOR ASS'Y
5-1	CPIPCB213JBKZ	AX			1	TUBE ASS'Y
5-3	PCOV-B485JBFZ	AF			1	SIDE COVER
5-9	LBND-A046JBE0	AC			2	FIXING BAND
5-10	PFPFPD646JBEZ	AE			1	CABINET INSULATOR E
6-1	QW-VZF947JBZZ	AG			1	LEAD WIRE (for PC unit)
7-2	DPLT-A083JBKZ	AP			1	MOUNTING ANGLE ASS'Y
7-3	PPLTNA118JBWZ	AD			1	PIPE GAUGE
8-14	CGID-A047JBKZ	AT			1	FILTER GUIDE KJH

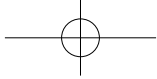

NO.	PARTS CODE	PRICE RANK	NEW MARK	PARTS RANK	Q'TY USED PER MODEL	DESCRIPTION
8-15	CGID-A045JBKZ	AU			1	FILTER GUIDE K
8-22	LHLD-A995JBFZ	AG			1	THERMISTOR HOLDER
8-27	LHLD-A991JBFA	AC			1	GUIDE STRONG
8-28	PGID-A167JBFA	AD			1	FILTER GUIDE L
8-29	PGID-A168JBFA	AD			1	FILTER GUIDE R
8-30	PGID-A169JBFA	AD			1	FILTER GUIDE C

### [2] Panel opening and shutting mechanism R Assembly

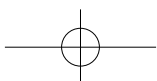
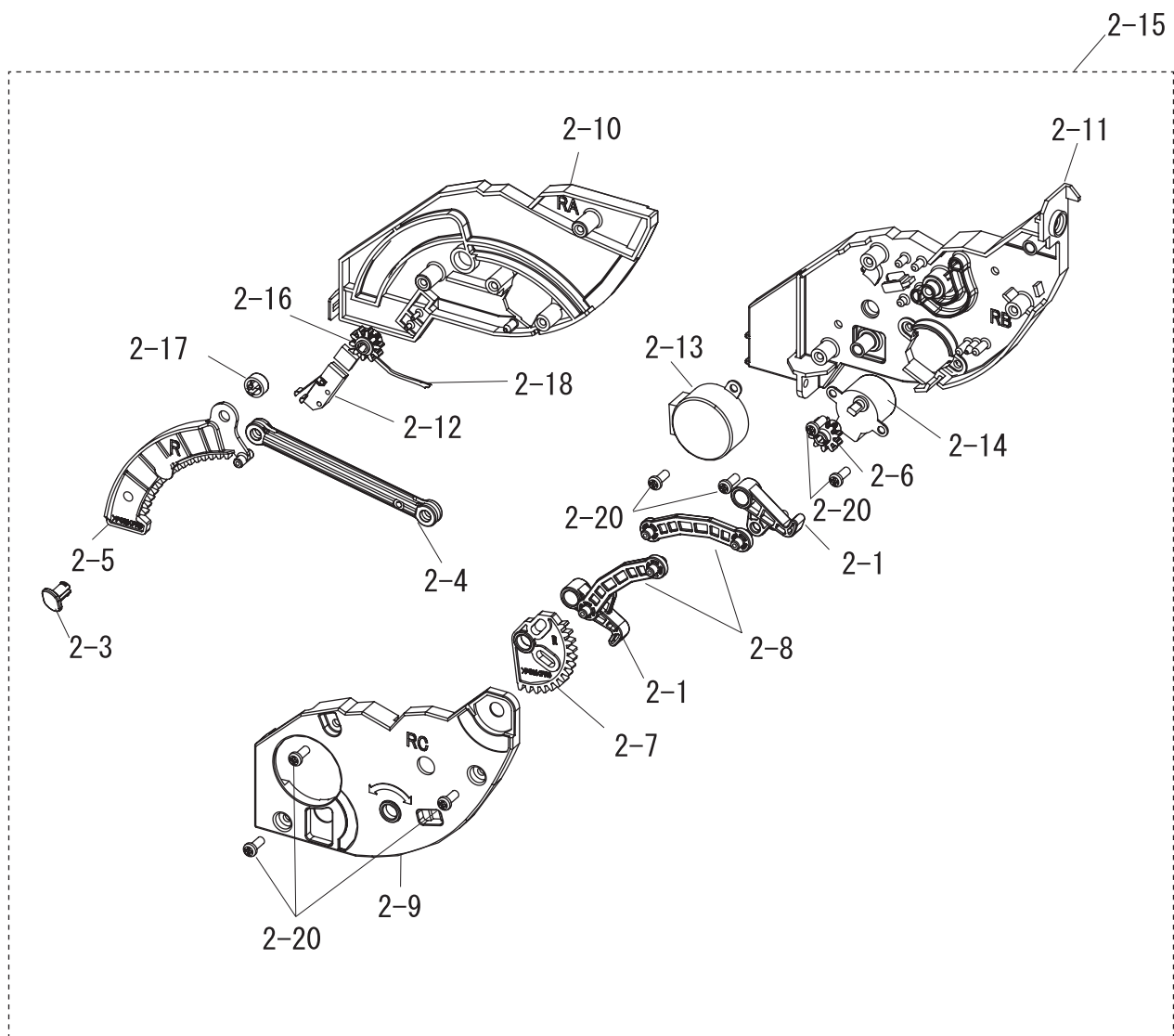

NO.	PARTS CODE	PRICE RANK	NEW MARK	PARTS RANK	Q'TY USED PER MODEL	DESCRIPTION
<b>[2] Panel opening and shutting mechanism R Assembly</b>						
2-15	CBOX-A053JBKZ	AX			1	PANEL MECHANISM L ASS'Y
2-1	LHLD-A943JBFB				2	HOOK
2-3	LPIN-A009JBEZ	AA			1	Pin
2-4	MARMPA067JBMA	AH			1	GEAR-C
2-5	MCAMPA010JBFZ	AC			1	CAM
2-6	NGER-A040JBEZ	AC			1	CAM L
2-7	NGER-A041JBEZ	AC			1	GEAR 35
2-8	NSFT-A047JBFZ	AD			2	HOOK ARM
2-9	PCAS-A076JBFA	AE			1	CASE LC
2-10	PCAS-A077JBFA	AE			1	DESCRIPTION
2-11	PCAS-A078JBFA	AE			1	CASE LA
2-12	QSW-MA013JBZZ	AF			1	CASE LB
2-13	RMOT-A164JBZZ	AM			1	SWITCH
2-14	RMOT-A172JBZZ	AL			1	LEAD WIRE
2-16	MCAMPA012JBFZ	AC			1	BEARING
2-17	NBRGPA001JBEZ	AB			1	GEAR 24
2-18	QW-VZF950JBZZ	AE			1	STEPPING MOTOR
2-20	XUPS740P10000				7	SCREW

### [3] Panel opening and shutting mechanism L Assembly

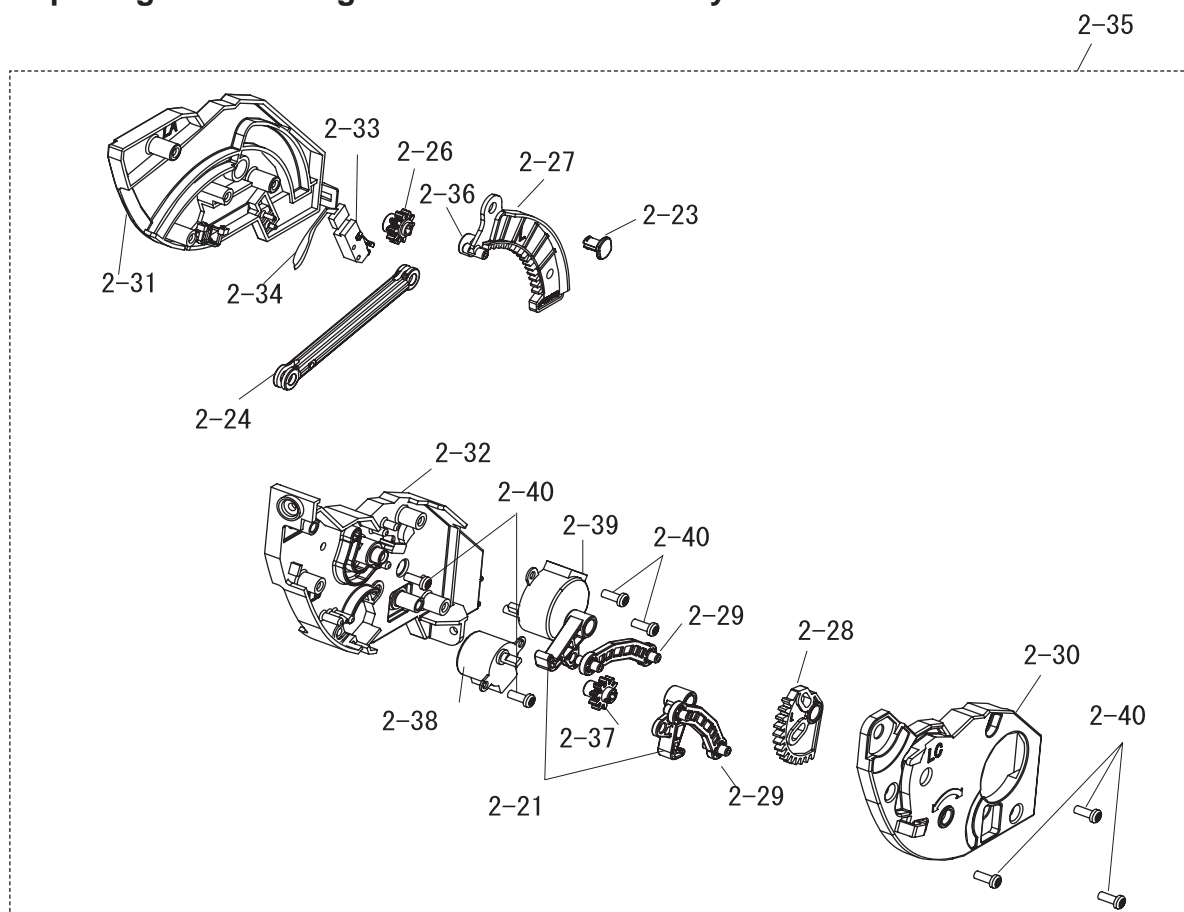

NO.	PARTS CODE	PRICE RANK	NEW MARK	PARTS RANK	Q'TY USED PER MODEL	DESCRIPTION
<b>[3] Panel opening and shutting mechanism R Assembly</b>						
2-35	CBOX-A054JBKZ	AX			1	PANEL MECHANISM L ASS'Y
2-21	LHLD-A943JBFB				2	HOOK
2-23	LPIN-A009JBEZ	AA			1	Pin
2-24	MARMPA067JBMA	AH			1	GEAR-C
2-26	MCAMPA012JBFZ	AC			1	CAM
2-27	MCAMPA013JBFZ	AC			1	CAM L
2-28	NGER-A041JBEZ	AC			1	GEAR 35
2-29	NSFT-A047JBFZ	AD			2	HOOK ARM
2-30	PCAS-A079JBFA	AE			1	CASE LC
2-31	PCAS-A080JBFA	AE			1	CASE LA
2-32	PCAS-A081JBFA	AE			1	CASE LB
2-33	QSW-MA013JBZZ	AF			1	SWITCH
2-34	QW-VZF949JBZZ	AE			1	LEAD WIRE
2-36	NBRGPA001JBEZ	AB			1	BEARING
2-37	NGER-A040JBEZ	AC			1	GEAR 24
2-38	RMOT-A167JBZZ	AM			1	STEPPING MOTOR
2-39	RMOT-A173JBZZ	AL			1	STEPPING MOTOR
2-40	XUPS740P10000				7	SCREW

**[4] ACCESSORY PARTS**

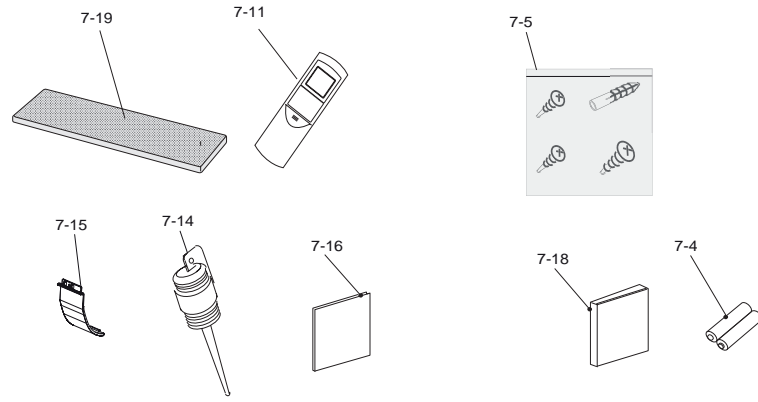

NO.	PARTS CODE	PRICE RANK	NEW MARK	PARTS RANK	Q'TY USED PER MODEL	DESCRIPTION
<b>[4] ACCESSORY PARTS</b>						
7-4	UBATUA027JBE0	AD			1	BATTERY
7-5	FFZK-A247JBKZ	AG			1	SCREWS KIT
7-11	CRMC-A899JBEZ	AX	N		1	REMOTE CONTROLER
7-14	USPT-A003CDEZ	AF			1	SPUIT
7-15	LHLD-A998JBKZ	AF			1	COVER (for Cabele)
7-16	TINS-B480JBRZ	AE	N		1	INSTALLATION MANUAL
7-18	TINSE823JBRZ	AG	N		1	OPERATION MANUAL
7-19	CFIL-A106JBKZ	AS			1	PURIFY FILTER ASS'Y
<b>[5] OTHER PARTS</b>						
1-22	QFS-GA078JBZZ	AC			1	FUSE (3.15A 250V)
1-23	VHVTNR9V511-A+	AC			1	VARISTOR
5-1-2	PSEN-A070JBKZ	AG			1	FLERE NUT ASS'Y 3/8
5-1-5	PSEN-A071JBKZ	AF			1	FLERE NUT ASS'Y 1/4
10-2	TLAB-D386JBRZ	AB			1	ERROR CODE LABEL
10-3	TLAB-D387JBRZ	AB			1	URGENT LABEL
10-4	TLAB-D388JBRZ	AB			1	SERVICE LABEL
11-5	LX-BZA075JBE0	AA			1	SPECIAL SCREW
11-9	XTPS730P10000	AA			2	SCREW
11-10	XTPS740P08000	AA			4	SCREW
11-11	XTPS740P12000	AA			1	SCREW
11-12	XTPS740P14000	AC			8	SCREW
11-14	XTTS740P10000	AA			1	SCREW
11-15	XTTS740P12000	AA			1	SCREW
11-16	XTTS740P14000	AA			4	SCREW
11-18	XTTS740P20000	AA			1	SCREW
11-21	XTPS740P16000	AA			1	SCREW
11-22	QW-VZG030JBZZ	AE			1	LEAD WIRE
11-23	QW-VZG031JBZZ	AH			1	LEAD WIRE 5P
11-24	QW-VZG032JBZZ	AG			1	LEAD WIRE 6P
11-25	QW-VZG033JBZZ	AE			1	LEAD WIRE

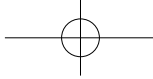
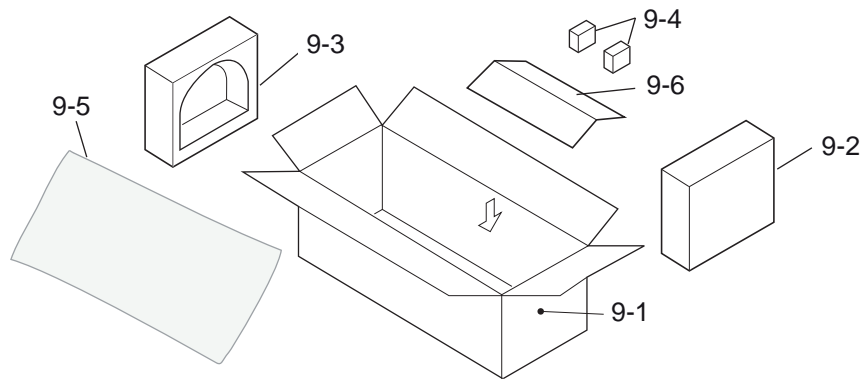
**[6] INDOOR PACKING PARTS**

NO.	PARTS CODE	PRICE RANK	NEW MARK	PARTS RANK	Q'TY USED PER MODEL	DESCRIPTION
<b>[6] INDOOR PACKING PARTS</b>						
9-1	SPAKCE471JBEZ	AP	N		1	PACKING CASE
9-2	SPADBA448JBEZ	AG			1	PAD R
9-3	SPADBA449JBEZ	AG			1	PAD L
9-4	SPADBA462JBEZ	AC			2	CABI PAD
9-5	SSAKAA106JBEZ	AD			1	BAG
9-6	SPAKCJ944YDEZ	AD			1	CASE





NO.	PARTS CODE	PRICE RANK	NEW MARK	PARTS RANK	Q'TY USED PER MODEL	DESCRIPTION
<b>[7] OUTDOOR UNIT PARTS</b>						
1-1	CMOTLB471JBEZ	BG			1	FAN MOTOR
1-2	DSGY-F269JBKZ	BS			1	CONTROL BOARD UNIT
1-2-6	RH-IXB019JBZZ	AY			1	IPM
1-2-7	VHDD25XB60+-F	AG			1	DIODE BRIDGE
1-4	RCILZA031JBZZ	AV			1	REACTOR
1-6	QTANZA074JBZZ	AP			1	TERMINAL BOARD
1-7	FW-VZA070JBKZ	AM			1	WIRE
1-10	RNF--A001VBE0	AH			3	FERRITE CORE
1-11	RH-HXA154JBZZ	AQ			1	THERMISTOR
1-12	LX-BZA075JBE0	AA			1	SPECIAL SCREW
2-1	LANGKA263JBPZ	AN			1	MOTOR ANGLE
2-2	CCAB-A550JBKZ	AP			1	TOP PLATE ASS'Y
2-3	TLABCE075JBRZ	AC	N		1	WIRING DIAGRAM
2-4	LX-BZA355JBEZ	AG			4	SPECIAL SCREW
2-5	LX-NZA412JBEZ	AC			1	SPECIAL NUT
2-7	CFTA-A268JBKZ	AK			1	COVER
2-7-1	PCOV-A594JBPZ	AD			1	TERMINAL COVER
2-7-2	PFTA-A090JBFA	AF			1	COVER
2-7-3	PSEL-C025JBEZ	AC			1	SEALNET SEAL
2-7-4	PSEL-C225JBEZ	AA			1	SEAL
2-7-5	PSEL-C116JBEZ	AA			1	CONDENSER SEAL
2-7-6	PSEL-C157JBEZ	AC			1	SEAL
2-8	PRDAFA219JBEZ	AN			1	HEAT SINK
2-9	LHLD-A684JBFA	AL			1	HOLDER
2-10	LHLD-A685JBFA	AE			1	HOLDER
2-11	DBOX-A077JBWZ	AP			1	CONTROL BOX ASS'Y
2-12	PDAI-A239JBWZ	AF			1	TERMINAL HOLDER
2-13	PCOV-A595JBFZ	AD			1	COVER
2-14	PSKR-A284JBPZ	AP			1	BULKHEAD
2-15	GCAB-A376JBTA	AW			1	FRONT PANEL
2-16	GGADPA021JBFA	AQ			1	FAN GUARD
2-17	JHNDPA015JBFA	AD			1	HANDLE
2-18	LHLD-A449JBF0	AD			1	THERMISTOR HOLDER
2-19	LHLD-0079SRFZ	AD			1	CORD CLAMP
2-20	LHLD-A699JBFA	AD			1	HOLDER BASE
2-21	MSPR-A195JBEZ	AF			2	SPRING
2-23	MSPR-A212JBEZ	AD			1	THERMISTOR SPRING
2-24	MSPR-A208JBEZ	AC			1	SPRING
2-25	NFANPA145JBEZ	AU			1	PROPELLER FAN
2-26	PPLT-B028JBTA	AR	N		1	SIDE COVER R
2-27	PSPF-B004JBEZ	AH			2	COMP COVER TOP
2-28	PSPF-B005JBEZ	AS			1	COMPRESSOR COVER
2-31	TLAB-C511JBRA	AC			1	LABEL
2-32	TLABBA286JBRA	AG			1	IVT LABEL
2-33	TSPC-J084JBRZ	AC	N		1	NAME LABEL

2-34	PPLT-A195JBTA	AV		1	SIDE COVER L
2-35	PSEL-E206JBEZ	AE		1	BASE PAN SEAL
2-37	PCOV-A997JBWZ	AK		1	COVER
2-38	PSEL-C685JBEZ	AB		1	SEAL
2-39-2	PSEL-C769JBEZ	AA		1	SEAL
2-39-3	PSEL-C684JBEZ	AA		1	SEAL
2-39-6	PSEL-C345JBEZ	AA		2	SEAL
2-39-7	PSEL-C767JBEZ	AA		1	SEAL
2-40	PSEL-C029JBEZ	AA		1	SEAL A
2-41	PSEL-C222JBEZ	AA		1	SEAL B
2-42	PSEL-C270JBEZ	AB		1	SEAL
2-43	PFPFPD261JBEZ	AD		1	INSULATOR
2-44	PFPFPD262JBEZ	AD		1	INSULATOR
2-46-1	PSEL-C341JBEZ	AA		1	SEAL SIDE-R
2-46-2	PSEL-C340JBEZ	AA		1	SEAL SIDE-R
2-46-3	PSEL-C339JBEZ	AA		1	SEAL
2-47-1	PSEL-C342JBEZ	AA		1	SEAL
2-48-1	PSEL-C338JBEZ	AC		2	SEAL TOP
2-48-2	PSEL-C337JBEZ	AA		1	SEAL TOP
2-56	PSEL-E103JBEZ	AD		1	CONDENSER SEAL
2-57	PSEL-D063JBEZ	AA		1	INSULATOR
2-58	PSEL-0194SRE0	AA		1	SEAL
2-59	PSEL-C491JBEZ	AA		1	F-PANEL SEAL
2-60-1	PSEL-E211JBEZ	AA		1	SEAL SIDE-L A
2-60-2	PSEL-E212JBEZ	AA		1	SEAL SIDE-L B
3-0	CCHS-B127JBKZ	AZ		1	BASE PAN ASS'Y
3-1	CCHS-A931JBTA	AZ		1	BASE PAN SUB ASS'Y
3-2	DVLV-A857JBKZ	AV		1	3WAY VALVE UNIT
3-3	PFPFPE118JBEZ	AA		1	BASE PAN INSULATOR A
3-4	PFPFPE119JBEZ	AE		1	BASE PAN INSULATOR B
3-5	DVLV-A757JBKZ	AQ		1	2WAY VALVE UNIT
3-6	CVLV-B279JBKZ	BK	N	1	REVERSE VALVE ASS'Y
3-7	DVLV-B442JBKZ	AS	N	1	CONTROL VALVE ASS'Y
3-8	CCIL-A142JBKZ	AP		1	COIL ASS'Y
3-9	PVLVXA085JBEZ	AY		1	VALVE
3-10	PDAI-A123JBTA	AH		1	FLARE COUPLING BASE
3-11	PGUM-A203JBEZ	AE		2	TUBE HOLDER RUBBER
3-12	DCON-A802JBPZ	BT		1	CONDENSER ASS'Y
3-13	FCMPRA379JBKZ	CF	N	1	COMPRESSOR
3-14	GLEG-A149JBEZ	AE		3	COMPRESSOR CUSHION
3-15	LX-NZA313JBEZ	AD		3	SPECIAL NUT
3-18	PCOV-B202JBEZ			1	TERMINAL COVER
3-19	PSEL-C903JBEZ			1	TERMINAL GASKET
3-20	PSPF-A977JBEZ	AM		1	COMPRESSOR COVER
3-21	PSPF-B083JBEZ	AC		1	COMPRESSOR COVER
3-22	CPIPCB352JBKZ	AQ		1	HEAT TUBE ASS'Y
3-23	PGUMSA415JBEZ	AC		3	DAMPER RUBBER
3-24	PGUMS0170JBE0	AC		1	DAMPER RUBBER
3-25	PFPFPE148JBEZ	AB		1	PAN INSULATOR C

NO.	PARTS CODE	PRICE RANK	NEW MARK	PARTS RANK	Q'TY USED PER MODEL	DESCRIPTION
3-26	PGUMSA386JBEZ	AD			1	RUBBER
3-6-1	DVLV-B441JBKZ	BE	N		1	REVERSE VALVE ASS'Y
3-6-2	PSRN-A091JBEZ	AG			1	STRAINER
3-6-3	PFPFPE966JBEZ	AE	N		1	PIPE INSULATOR
3-6-4	LBND-A047JBE0	AA			8	WIRE FIXING BAND
3-27	PSEL-E531JBEZ	AA	N		1	THERMISTOR SEAL

**[8] OTHER PARTS**

1-2-1	QFS-CA001JBZZ	AF			1	FUSE 20A 250V
1-2-2	QFS-GA077JBZZ	AC			1	FUSE 2A 250V
1-2-3	QFS-GA078JBZZ	AC			1	FUSE 3.15A 250V
1-2-4	QFS-CA002JBZZ	AF			1	FUSE 15A 250V
2-50	PSEL-C345JBEZ	AA			2	SEAL
2-51	PSEL-C684JBEZ	AA			1	SEAL
2-52	PSEL-C767JBEZ	AA			1	SEAL
2-53	PSEL-C769JBEZ	AA			1	SEAL
3-7-1	RMOTSA043JBZZ	AT			1	COIL
3-7-2	PVLVRA042JBEZ	AR			1	CONTROL VALVE

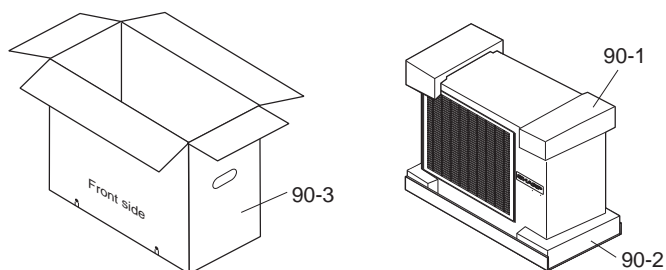
**[9] OUTDOOR PACKING PARTS**

NO.	PARTS CODE	PRICE RANK	NEW MARK	PARTS RANK	Q'TY USED PER MODEL	DESCRIPTION
<b>[9] OUTDOOR PACKING PARTS</b>						
90-1	CPADBA048JBKZ	AF			1	TOP PAD ASS'Y
90-2	CPADBA049JBKZ	AK			1	BOTTOM PAD ASS'Y
90-3	SPAKCE472JBEZ	AP	N		1	PACKING CASE

■ INDEX

PARTS CODE	No.	PRICE RANK	NEW MARK	PART RANK
<b>[ C ]</b>				
CBOX-A053JBKZ	2-15	AX		
CBOX-A054JBKZ	2-35	AX		
CCAB-A550JBKZ	2-2	AP		
CCHS-A931JBTA	3-1	AZ		
CCHS-B127JBKZ	3-0	AZ		
CCIL-A142JBKZ	3-8	AP		
CCOV-A255JBKZ	3-3	AE		
CDAI-A046JBKZ	3-14	AZ		
CFIL-A106JBKZ	7-19	AS		
CFTA-A268JBKZ	2-7	AK		
CGID-A045JBKZ	8-15	AU		
CGID-A047JBKZ	8-14	AT		
CHLD-A139JBKZ	3-27	AF		
CKITTA125AKKZ	1-12	BF		
CMOT-A515JBKZ	1-1	BF		
CMOTLB471JBEZ	1-1	BG		
CPADBA048JBKZ	90-1	AF		
CPADBA049JBKZ	90-2	AK		
CPIPCB213JBKZ	5-1	AX		
CPIPCB352JBKZ	3-22	AQ		
CPNL-A631JBKZ	3-31	AY		
CRMC-A899JBEZ	7-11	AX	N	
CSRA-A715JBKZ	3-37	AY		
CVLV-B279JBKZ	3-6	BK	N	
CWAK-C834JBKZ	3-44	BN		
<b>[ D ]</b>				
DBOX-A077JBWZ	2-11	AP		
DCHS-A638JBKZ	3-15	AY		
DCON-A802JBPZ	3-12	BT		
DCOV-A293JBKZ	3-72	AF		
DCOV-A327JBKZ	3-10	AD		
DEVA-A407JBKZ	5-0	BP		
DPLT-A083JBKZ	7-2	AP		
DSGY-C403JBKZ	1-27			
DSGY-F268JBKZ	1-2		N	
DSGY-F269JBKZ	1-2	BS		
DVLV-A757JBKZ	3-5	AQ		
DVLV-A857JBKZ	3-2	AV		
DVLV-B441JBKZ	3-6-1	BE	N	
DVLV-B442JBKZ	3-7	AS	N	
<b>[ F ]</b>				
FCMPRA379JBKZ	3-13	CF	N	
FFZK-A247JBKZ	7-5	AH		
FSGY-A583JBKZ	1-24			
FSGY-A709JBKZ	1-17	BB		
FW-VZA070JBKZ	1-7	AM		

PARTS CODE	No.	PRICE RANK	NEW MARK	PART RANK
<b>[ G ]</b>				
GCAB-A376JBTA	2-15	AW		
GGAD-A069JBTA	2-5A-5	AN		
GGAD-A072JBTA	2-5B-5	AN		
GGADPA021JBFA	2-16	AQ		
GLEG-A149JBEZ	3-14	AE		
<b>[ H ]</b>				
HDECQA231JBRA	3-57	AR		
HPNL-B019JBRA	3-49	AN		
<b>[ J ]</b>				
JBTN-A012JBFA	3-32	AD		
JHNDPA015JBFA	2-17	AC		
<b>[ L ]</b>				
LANGKA263JBPZ	2-1	AN		
LBND-A014JBE0	1-28	AB		
LBND-A046JBE0	5-9	AC		
LBND-A047JBE0	3-6-4	AA		
LHLD-0079SRFZ	2-19	AD		
LHLD-A394JBFA	3-65	AC		
LHLD-A449JBF0	2-18	AD		
LHLD-A684JBFA	2-9	AL		
LHLD-A685JBFA	2-10	AE		
LHLD-A699JBFA	2-20	AD		
LHLD-A879JBFA	3-46			
LHLD-A933JBFA	3-55	AF		
LHLD-A943JBFB	2-1			
LHLD-A943JBFB	2-21			
LHLD-A944JBFB	3-4	AE		
LHLD-A945JBFB	3-58	AE		
LHLD-A946JBFB	3-59	AE		
LHLD-A947JBFZ	3-66	AC		
LHLD-A948JBFA	3-60	AC		
LHLD-A951JBFA	3-67	AC		
LHLD-A956JBFA	3-53	AD		
LHLD-A960JBFZ	3-54	AD		
LHLD-A991JBFA	8-27	AC		
LHLD-A995JBFZ	8-22	AG		
LHLD-A998JBKZ	7-15	AF		
LPIN-A009JBEZ	2-3	AA		
LPIN-A009JBEZ	2-23	AA		
LPIN-A010JBEZ	3-61	AA		
LPLT-A058JBPZ	3-36	AC		
LX-BZA075JBE0	11-5	AA		
LX-BZA075JBE0	1-12	AA		
LX-BZA355JBEZ	2-4	AG		
LX-NZA313JBEZ	3-15	AD		
LX-NZA412JBEZ	2-5	AC		

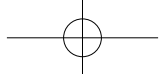

PARTS CODE	No.	PRICE RANK	NEW MARK	ADPART RAACNKAF
<b>[ M ]</b>				
MARMPA067JBMA	2-4	AH		
MARMPA067JBMA	2-24	AH		
MCAMPA010JBFZ	2-5	AC		
MCAMPA012JBFZ	2-16	AC		
MCAMPA012JBFZ	2-26	AC		
MCAMPA013JBFZ	2-27	AC		
MJNTPA150JFBF	3-16	AD		
MJNTPA155JBFA	3-17	AD		
MLOV-A501JFBF	3-18	AF		
MLOV-A502JFBF	3-19	AF		
MLOV-A503JFBF	3-38	AF		
MSPR-A188JBEZ	3-33	AC		
MSPR-A195JBEZ	2-21	AF		
MSPR-A208JBEZ	2-24	AC		
MSPR-A212JBEZ	2-23	AD		
<b>[ N ]</b>				
NBRG-A038JBFA	3-39	AB		
NBRGPA001JBEZ	2-17	AB		
NBRGPA001JBEZ	2-36	AB		
NFANCA116JBEZ	3-68	AT		
NFANPA145JBEZ	2-25	AU		
NGER-A040JBEZ	2-6	AC		
NGER-A040JBEZ	2-37	AC		
NGER-A041JBEZ	2-7	AC		
NGER-A041JBEZ	2-28	AC		
NSFT-A047JBFZ	2-8	AC		
NSFT-A047JBFZ	2-29	AC		
<b>[ P ]</b>				
PBOX-A515JBFZ	3-1	AM		
PCAS-A076JBFA	2-9	AE		
PCAS-A077JBFA	2-10	AE		
PCAS-A078JBFA	2-11	AE		
PCAS-A079JBFA	2-30	AE		
PCAS-A080JBFA	2-31	AE		
PCAS-A081JBFA	2-32	AE		
PCOV-A594JBPZ	2-7-1	AD		
PCOV-A595JBFZ	2-13	AD		
PCOV-A997JBWZ	2-37	AK		
PCOV-B202JBEZ	3-18			
PCOV-B381JBFA	3-47			
PCOV-B467JBFA	3-7	AC		
PCOV-B475JBWZ	3-2	AN		
PCOV-B476JBWZ	3-11	AG		
PCOV-B477JBWZ	3-42	AD		
PCOV-B485JBFZ	5-3	AF		
PCOV-B501JBFA	3-5	AD		
PCOV-B502JBFA	3-6	AD		
PCOV-B503JFBF	3-12	AC		
PCOV-B521JBFA	3-64	AD		

PARTS CODE	No.	PRICE RANK	NEW MARK	ANADPART RAACNKAF
PCOV-B525JFBF	3-69	AC		
PCOV-B526JFBF	3-48	AE		
PCOV-B533JBFA	3-56	AH		
PDAI-A123JBTA	3-10	AH		
PDAI-A218JBFA	3-43	AK		
PDAI-A231JBFA	3-20	AG		
PDAI-A239JBWZ	2-12	AF		
PDAI-A240JBWZ	3-80	AF		
PFILMA249JBEA	3-50	AL		
PFPFPD261JBEZ	2-43	AD		
PFPFPD262JBEZ	2-44	AD		
PFPFPD504JBEZ	3-21	AC		
PFPFPD505JBEZ	3-22	AC		
PFPFPD549JBEZ	3-23	AA		
PFPFPD646JBEZ	5-10	AE		
PFPFPE118JBEZ	3-3	AA		
PFPFPE119JBEZ	3-4	AE		
PFPFPE148JBEZ	3-25	AB		
PFPFPE966JBEZ	3-6-3	AE	N	
PFTA-A090JBFA	2-7-2	AF		
PFTA-A124JFBF	3-70	AD		
PFTA-A125JFBF	3-62	AB		
PGID-A166JBFA	3-40	AC		
PGID-A167JBFA	8-28	AD		
PGID-A168JBFA	8-29	AD		
PGID-A169JBFA	8-30	AD		
PGUM-A203JBEZ	3-11	AE		
PGUMMA381JBEZ	3-41	AC		
PGUMS0170JBE0	3-24	AC		
PGUMSA386JBEZ	3-26	AD		
PGUMSA415JBEZ	3-23	AC		
PHOS-A052JBEZ	3-35	AG		
PPLT-A195JBTA	2-34	AV		
PPLT-A661JBFZ	3-71	AF	N	
PPLT-B028JBTA	2-26	AR		
PPLTNA118JBWZ	7-3	AD		
PRDAFA219JBEZ	2-8	AN		
PSEL-0194SRE0	2-58	AA		
PSEL-C025JBEZ	2-7-3	AC		
PSEL-C029JBEZ	2-40	AA		
PSEL-C116JBEZ	2-7-5	AA		
PSEL-C157JBEZ	2-7-6	AC		
PSEL-C222JBEZ	2-41	AA		
PSEL-C225JBEZ	2-7-4	AA		
PSEL-C270JBEZ	2-42	AB		
PSEL-C337JBEZ	2-48-2	AA		
PSEL-C338JBEZ	2-48-1	AC		
PSEL-C339JBEZ	2-46-3	AA		
PSEL-C340JBEZ	2-46-2	AA		
PSEL-C341JBEZ	2-46-1	AA		

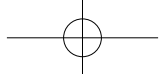

PARTS CODE	No.	PRICE RANK	NEW MARK	ANADPART RAACNKAF
PSEL-C342JBEZ	2-47-1	AA		
PSEL-C345JBEZ	2-39-6	AA		
PSEL-C345JBEZ	2-50	AA		
PSEL-C491JBEZ	2-59	AA		
PSEL-C684JBEZ	2-39-3	AA		
PSEL-C684JBEZ	2-51	AA		
PSEL-C685JBEZ	2-38	AB		
PSEL-C767JBEZ	2-39-7	AA		
PSEL-C767JBEZ	2-52	AA		
PSEL-C769JBEZ	2-39-2	AA		
PSEL-C769JBEZ	2-53	AA		
PSEL-C903JBEZ	3-19			
PSEL-D063JBEZ	2-57	AA		
PSEL-E103JBEZ	2-56	AD		
PSEL-E206JBEZ	2-35	AE		
PSEL-E211JBEZ	2-60-1	AA		
PSEL-E212JBEZ	2-60-2	AA		
PSEL-E531JBEZ	3-27	AA	N	
PSEN-A070JBKZ	5-1-2	AG		
PSEN-A071JBKZ	5-1-5	AF		
PSHE-A294JBEZ	3-74	AC		
PSKR-A284JBPZ	2-14	AP		
PSPF-A977JBEZ	3-20	AM		
PSPF-B004JBEZ	2-27	AH		
PSPF-B005JBEZ	2-28	AS		
PSPF-B083JBEZ	3-21	AC		
PSRN-A091JBEZ	3-6-2	AG		
PVLVRA042JBEZ	3-7-2	AR		
PVLVXA085JBEZ	3-9	AY		
<b>[ Q ]</b>				
QFS-CA001JBZZ	1-2-1	AF		
QFS-CA002JBZZ	1-2-4	AF		
QFS-GA077JBZZ	1-2-2	AC		
QFS-GA078JBZZ	1-22	AC		
QFS-GA078JBZZ	1-2-3	AC		
QSW-MA013JBZZ	2-12	AF		
QSW-MA013JBZZ	2-33	AF		
QTANZA054JBZZ	1-10	AH		
QTANZA074JBZZ	1-6	AP		
QW-VZF947JBZZ	6-1	AG		
QW-VZF948JBZZ	1-26	AD		
QW-VZF949JBZZ	2-34	AE		
QW-VZF950JBZZ	2-18	AE		
QW-VZG030JBZZ	11-22	AE		
QW-VZG031JBZZ	11-23	AH		
QW-VZG032JBZZ	11-24	AG		
QW-VZG033JBZZ	11-25	AE		
QW-VZG044JBZZ	1-25	AG		
QW-VZG165JBZZ	1-29	AE		

PARTS CODE	No.	PRICE RANK	NEW MARK	ANADPART RAACNKAF
<b>[ R ]</b>				
RCILZA031JBZZ	1-4	AV		
RH-HXA113JBZZ	1-4	AG		
RH-HXA154JBZZ	1-11	AQ		
RH-IXB019JBZZ	1-2-6	AY		
RMOT-A164JBZZ	2-13	AM		
RMOT-A167JBZZ	2-38	AM		
RMOT-A172JBZZ	2-14	AL		
RMOT-A173JBZZ	2-39	AL		
RMOT-A174JBZZ	1-6	AK		
RMOT-A176JBZZ	1-8	AK		
RMOT-A179JBZZ	1-7	AK		
RMOTSA043JBZZ	3-7-1	AT		
RNF--A001VBE0	1-20	AH		
RNF--A001VBE0	1-10	AE		
<b>[ S ]</b>				
SPADBA448JBEZ	9-2	AG		
SPADBA449JBEZ	9-3	AG		
SPADBA462JBEZ	9-4	AC		
SPAKCE471JBEZ	9-1	AP	N	
SPAKCE472JBEZ	90-3	AP	N	
SPAKCJ944YDEZ	9-6	AD		
SSAKAA106JBEZ	9-5	AD		
<b>[ T ]</b>				
TINS-B480JBRZ	7-16	AF	N	
TINSEA823JBRZ	7-18	AH	N	
TLABBA286JBRA	2-32	AF		
TLAB-C511JBRA	2-31	AC		
TLABCC631JBRZ	10-6	AB		
TLABCE075JBRZ	2-3	AC	N	
TLAB-D386JBRZ	10-2	AB		
TLAB-D387JBRZ	10-3	AB		
TLAB-D388JBRZ	10-4	AB		
TSPC-J081JBRZ	10-1	AD	N	
TSPC-J084JBRZ	2-33	AC	N	
<b>[ U ]</b>				
UBATUA027JBE0	7-4	AD		
USPT-A003CDEZ	7-14	AF		
<b>[ V ]</b>				
VHDD25XB60+-F	1-2-7	AG		
VHVTNR9V511-A+	1-23	AC		
<b>[ X ]</b>				
XPSSJ20-12000	3-63	AB		
XTPS723P10000	2-19			
XTPS730P10000	11-9	AA		
XTPS740P08000	11-10	AA		
XTPS740P12000	11-11	AA		
XTPS740P14000	11-12	AC		
XTPS740P16000	11-21	AA		

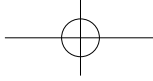

PARTS CODE	No.	PRICE RANK	NEW MARK	ANADPART RAACNKAF
XTTS740P10000	11-14	AA		
XTTS740P12000	11-15	AA		
XTTS740P14000	11-16	AA		
XTTS740P20000	11-18	AA		
XUPS740P10000	2-20			
XUPS740P10000	2-40			

